

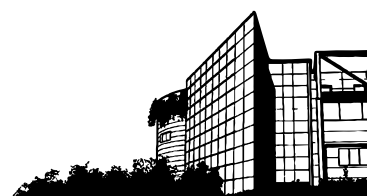





























































PIUSI
®













































MADE IN ITALY



FUEL PRODUCT RANGE

PRODUCT RANGE	PRODUCT CATEGORY	PRODUCT	PAGE	
FUEL MANAGEMENT SYSTEMS	FUEL MANAGEMENT SYSTEMS		OVERVIEW	8
		SOFTWARE	 B.SMART	10
			ADD-ONS	12
		DISPENSERS	 CUBE B.SMART	14
			 SELF SERVICE B.SMART	16
		CONTROL BOX	 MCBOX B.SMART	18
		SOFTWARE	 SSM2.0	20
			 DATA TRANSFER SSM 2.0	22
			 SSM 2.0 CLOUD	24
		DISPENSERS	 CUBE MC 2.0	26
			 SELF SERVICE MC 2.0	28
			 SELF SERVICE FM 2.0	30
		CONTROL BOX	 MCBOX 2.0	32
		SOFTWARE	 SSM 2018	34
			 DATA TRANSFER SSM 2018	36
		DISPENSERS	 CUBE MC	38
			 SELF SERVICE MC	40
		 SELF SERVICE FM	42	
	CONTROL BOX	 MCBOX	44	
DISPENSERS	MECHANICAL DISPENSERS			
		 CUBE	50	
		 SELF SERVICE K44	52	
KITS	ATEX KITS 	 EX50 DRUM 	58	
		 EX100 DRUM 	60	
		 EX140 DRUM 	62	
		 EX50 ST 	64	
	DRUM	 DRUM	66	
		 PICO	68	
	MOBILE	 BATTERY KIT	70	
		 PITSTOP	72	
		 PIUSIBOX	74	
		 CARRY	76	
	ST	 ST	78	
		 ST WITH METER	80	
		 ST WITH METER AND FILTER	82	
		 ST BOX	84	
		 ST 200 AC	86	
 ST 200 DC		88		
PUMPS	ATEX AC PUMPS 	 EX50 AC 	94	
		 EX100 	96	
		 EX140 	98	
	ATEX DC PUMPS 	 EX50 / EX75 DC 	100	
		AC PUMPS	 PANTHER AC	102
			 VISCOMAT VANE	104
			 E80 / E120	106
			 E140	108
			 E300	110
	DC PUMPS	 BP3000	112	
		 PANTHER DC	114	
		 BIPUMP	116	
	HAND PUMPS	 PIUSI HAND PUMP	118	
		 HAND PUMPS	120	

All Pictures shown are for illustration purpose only. Actual product may vary due to product enhancement.

PRODUCT RANGE	PRODUCT CATEGORY	PRODUCT	PAGE
METERS 	ATEX ELECTRONIC METERS 	 K24 ATEX 	126
	ATEX MECHANICAL METERS 	 K33 ATEX 	128
	ELECTRONIC METERS	 K150 ATEX 	130
		 K24	132
		 K600/3	134
		 K600 B/3	136
		 K600/4	138
		 K700 PULSER	140
		 K900	142
	MECHANICAL METERS	REMOTE DISPLAY	144
		 K33 / K44	146
 K150		148	
 K700		150	
NOZZLES 	ATEX AUTOMATIC NOZZLES 	 A60 / A140 ATEX 	156
	AUTOMATIC NOZZLES	 A60 / A80 / A120 / A140	158
	 A280	160	
MANUAL NOZZLES	 SELF 2000 / SELF 3000	162	
FILTRATION 	FILTERING SYSTEM	 FILTROLL	168
	FILTERS	 WATER CAPTOR	170
		 CLEAR CAPTOR	172
		 FUEL & BIOFUEL	174
		 FOOT VALVE	176
TANK MONITORING 	TANK LEVEL INDICATORS	 OCIO	180
		 OCIO 2.0	182
HOSE REEL 	OPEN HOSE REEL	 DIESEL HOSE REEL	188
ACCESSORIES 	ACCESS CONTROL	 ACCESS 85	194
	ACCESSORIES	 CONNECTORS	196
		 COUPLING&FITTINGS	198
		 FLANGED CONNECTIONS	200
		 HOSE&SWIVEL	202
MERCHANDISE 	MERCHANDISE		208

THE HISTORY OF KNOW-HOW

ABOUT US

PIUSI was established in 1953 in Suzzara, in the province of Mantua (Italy). For more than 60 years, PIUSI has been the major player in the world's leading markets with its full range of products for transferring, refilling and measuring lubricants, fuels and liquids such as gasoline, diesel, Diesel Exhaust Fluid (DEF), oil, water and grease. Some of PIUSI's main products include pumps, flow meters, nozzles, dispensers, hose reels, liquid level gauges, software and complete kits used by operators in agriculture, the automotive industry, workshops and garages, fleet management and transport by road and by sea. PIUSI products have many different uses such as monitoring and transferring fuel at trucking companies, refueling of agricultural vehicles, transferring fuels in construction and mining for heavy duty vehicles. The products are intuitive and easy to use; are suitable to be installed in a variety of contexts; are all made entirely in Italy; and all products express the innovation, quality, professionalism and R&D that have always distinguished PIUSI. Its headquarters are in Suzzara (Mantova - 150 km from Milan and Venice). The company currently employs more than 250 employees between sales, administration, R&D, production and logistics. PIUSI products are sold in more than 120 countries around the world thanks to a large network of distributors and the US branch based in Fort Lauderdale, FL, serving the North and South American markets.

1953

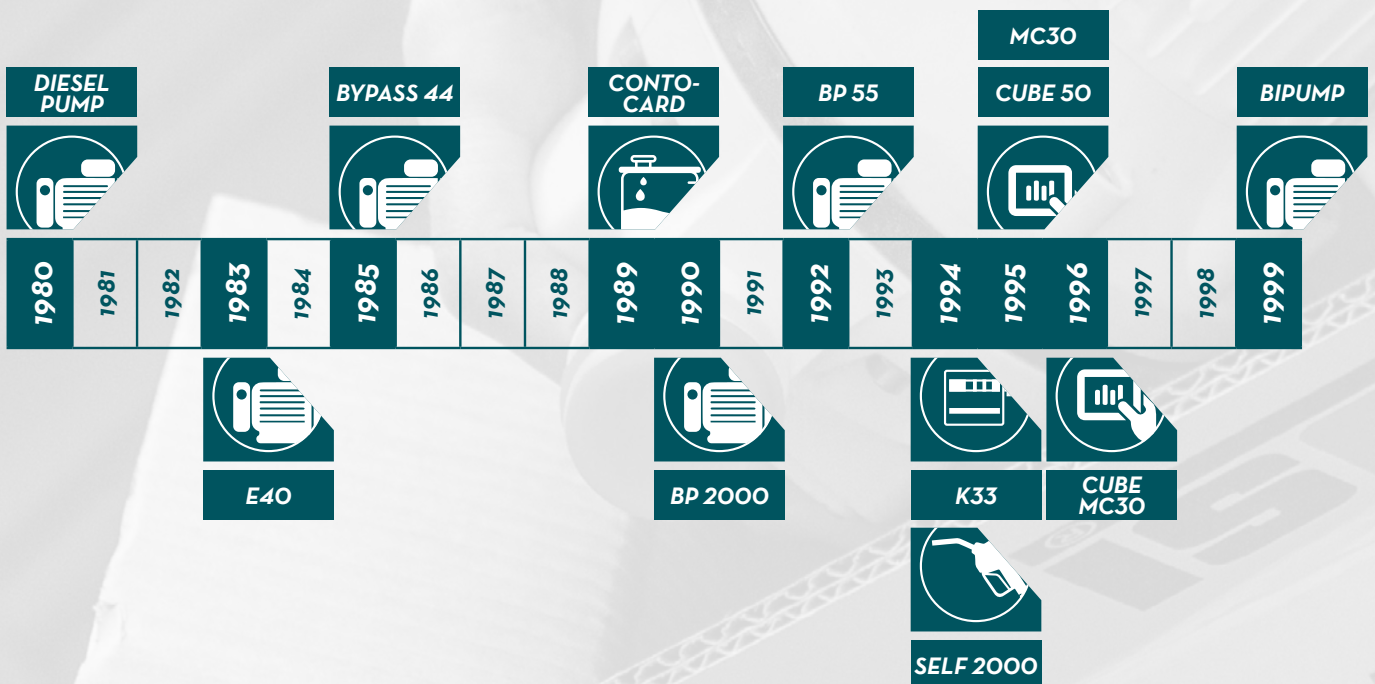

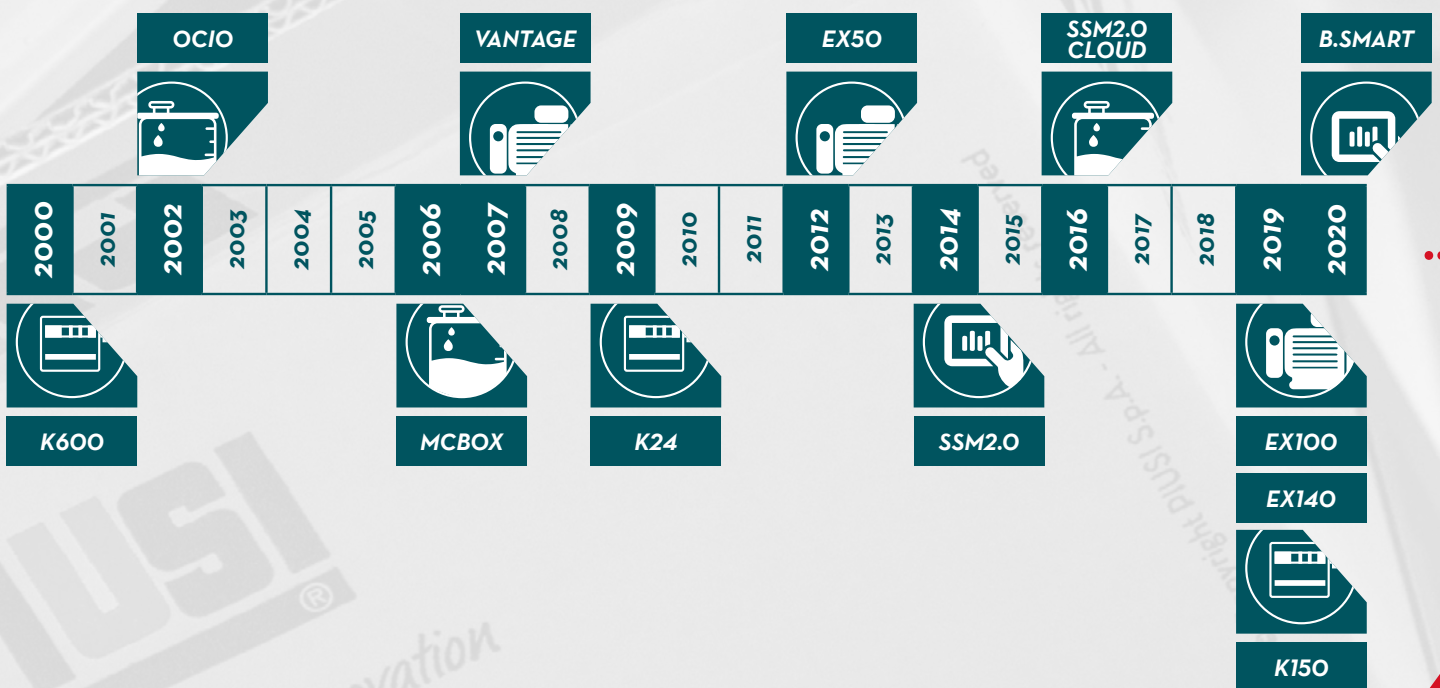



FUEL MANAGEMENT SYSTEMS

A solid red triangle is positioned in the bottom right corner of the page, pointing towards the top left. It is a simple, flat-colored geometric shape that adds a modern, dynamic touch to the minimalist design.



OVERVIEW

FEATURES:

ACCURATE DATA

- REAL AND ACCURATE CONSUMPTIONS' DATA ON EACH REFUELLING OPERATION MANAGED AUTOMATICALLY BY THE SYSTEM;
- OVERVIEW ON CONSUMPTIONS' TREND AND AVAILABLE RESIDUAL FUEL;

REDUCED COSTS

- CAREFUL AND MEASURED CONSUMPTION OF FUEL ALLOWS TO SAVE UP TO 20% OF FUEL EVERY YEAR

NO ABUSE

- A FUEL MANAGEMENT SYSTEM ALLOWS YOU TO TRACK WHO IS MAKING THE PROCEDURE, ON WHICH VEHICLE ALSO INDICATING THE DISPENSER USED IN ORDER TO CONTAIN ABUSES.

Fuel Management Systems (FMS) are technologically-advanced equipment that allow to measure, control and manage the consumptions of fuel (or other fluids) of fleets or other Company vehicles (such as for example the earth moving machines within the construction industry).

The consumption of fuel, diesel and petrol is an important part of the running costs of a fleet.

- How much fuel have you wasted in the past few months?
- How much fuel does each vehicle or driver consume?
- What was the trend of consumptions?

To have a clear and precise overview on the situation, you need a FMS.

A system linked to your dispensers and stations for fuel transferring that follow and trace all the refuelling operations also indicating who is the operator and the vehicle which is refuelled; all in real time.

PIUSI has developed 3 different FMS software suitable for all different requirements: B.SMART, SSM 2.0 and SELF SERVICE MANAGEMENT 2018.





FILTRATION



TANK MONITORING



HOSE REEL



ACCESSORIES



MERCHANDISE

INDEX



AIR



ANTIFREEZE



AdBlue®



BIODIESEL



DIESEL



FOOD



GASOLINE



GREASE



KEROSENE



OIL



WATER



WINDSCREEN

Why choose a PIUSI FMS?

With 70 years of history, PIUSI can supply not only all the technological and IT aspects of the software, but also - integrated - a wide range of dispensers suitable for all needs.

By choosing PIUSI, you will have - from a single supplier - not only the Software, but also the dispensing Hardware directly from the same Company.

		 Dispensing control ideal for: company that wants to monitor the quantity delivered.	 Consumption control ideal for: a company that wants to monitor and manage the quantities supplied, manage consumption and supply of fuels.	 Dispensing control ideal for: company that wants to monitor and manage the quantities delivered in the cloud without territorial limitations, with smart technologies.
GENERAL	PLATFORM	PC Software	PC Software	Cloud Software
	MULTISITE	NA	with SSM2.0 Cloud	YES
	MAX USERS	120/Dispenser	up to 1000	Unlimited
	MAX DISPENSERS	16	up to 20	Unlimited
	USER LOGIN	iButton/Pincode	iButton/Pincode	Mobile App
LIMIT SETTINGS	REMOTE USER/DISPENSER DEACTIVATION	NA	YES	YES
	USER DAY/WEEKLY LIMITS	NA	YES	COMING UP
	VEHICLE LIMITS	NA	YES	COMING UP
MANAGEMENT: • VEHICLES • SUPPLIERS • CONSUMPTIONS	REGISTRATION NUMBER	Manual entry	iButton	Mobile App
	USER VEHICLE ASSIGNMENT	NA	YES	COMING UP
	ODOMETER	YES	YES	YES
	EXTERNAL TRANSACTIONS	NA	YES	COMING UP
	FUEL CONSUMPTION MANAGEMENT	NA	YES	COMING UP
	ADBLUE CONSUMPTION MANAGEMENT	NA	YES	COMING UP
	FLUID SUPPLIERS MANAGEMENT	NA	YES	COMING UP
TANK LEVEL MANAGEMENT	TANK LOW LEVEL PUMP CUT-OFF	YES	YES	YES
	REMOTE TANK LEVEL MANAGEMENT	NA	YES	with Tank Watchdog Add-on
	MAX NO. OCIO	NA	up to 20	Unlimited - with Tank Watchdog Add-on
TANK ALARM	SOFTWARE ALARMS	NA	YES	YES
	HARDWARE ALARMS (W/OCIO)	YES	YES	YES
REPORT	TRANSACTION REPORT	YES	YES	YES
	TANK LEVEL REPORT	NA	YES	with Tank Watchdog Add-on
	FUEL PRICE TREND REPORT	NA	YES	with Tank Watchdog Add-on
	TRANSACTION GEOLOCALIZATION	NA	NA	with Mobile Add-on

IBUTTON: IN CASE OF EMERGENCY IF/OR SMARTPHONE IS ABSENT OR IT DOESN'T WORK

OVERVIEW



FUEL MANAGEMENT SYSTEMS



DISPENSERS



KITS



PUMPS



METERS



NOZZLES

B.SMART

FEATURES

- SIMPLE, INTUITIVE, SUITABLE FOR EVERYONE
- UNLIMITED TO FIT ALL NEED
- MONO OR MULTI-SITE
- SOFTWARE ALWAYS INCLUDED WITH THE DISPENSER
- BLUETOOTH
- CLOUD-BASED
- NO SOFTWARE INSTALLATION
- NO FEE
- ANALYSIS, CONTROL AND MANAGEMENT IN ONE CLICK

PERFORMANCE

DATA AVAILABLE ALWAYS TRANSACTIONS	NO SOFTWARE ON THE PC CLOUD
NO FEE UTILIZATION	BLUETOOTH NO WI-FI OR LAN CONNECTION

B.SMART is the Fuel Management System (FMS) by PIUSI designed and engineered for fleets of all sizes: small, medium, large, mono or multi-site. Innovative, simple and smart - the name carries its meaning - PIUSI B.SMART combines the quality and efficiency of PIUSI dispensers, with a Cloud-based software (APP for drivers and a web APP for fleet managers) driven by Bluetooth technology; that means no Wi-Fi or LAN network are required. Thus, it is possible to use B.SMART wherever; also in the more distant areas.

A FMS all in one: the fleet manager has just to choose the necessary dispensers; the software is always included in the "package" (no rental ore recurring fee will be required).



B.SMART

B.SMART is flexible and expandable: the same system easily fits to all requirements. It is only necessary to add the add-on needed to keep up with the evolution of the fleet.

B.SMART API AVAILABLE

THE B.SMART API ALLOWS YOU TO CONNECT AND EXCHANGE DATA WITH PLATFORM.

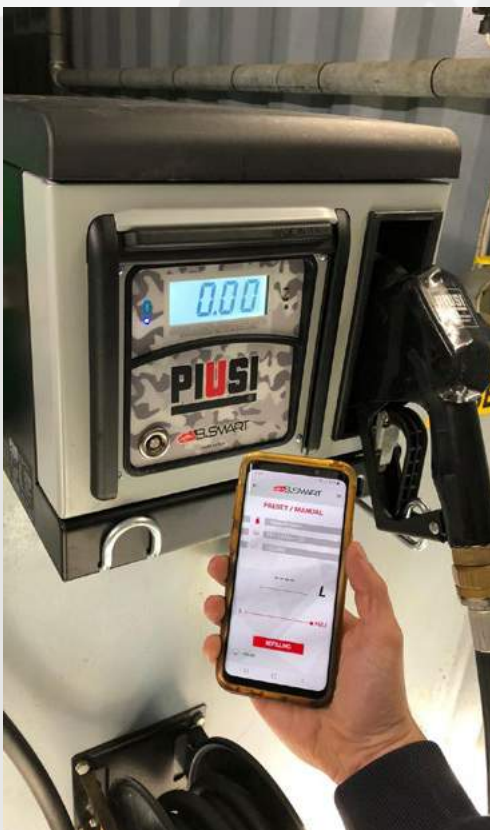



FILTRATION



TANK MONITORING



HOSE REEL



ACCESSORIES



MERCHANDISE

INDEX



AIR



ANTIFREEZE



AdBlue®



BIODIESEL



DIESEL



FOOD



GASOLINE



GREASE



KEROSENE



OIL



WATER



WINDSCREEN



APP

Dedicated to drivers, the APP for drivers just needs a smart device with Bluetooth to work properly: once the APP is open, the smartphone or tablet immediately connects to the dispenser to start the refueling operation.



HARDWARE

PIUSI B.SMART runs only with the dedicated range of dispensing devices: quality guaranteed by PIUSI; the highest technical performances and reliability, all form a unique supplier. Real time communication between the dispenser and the PC.



CLOUD

The core of B.SMART fuel management software is a Cloud-based service that tracks every refuelling operation and keeps every device synchronized.



WEB APP

Dedicated to fleet manager. No software installation: just log in and start immediately to monitor, manage and control consumptions of the fleet.



FUEL MANAGEMENT SYSTEMS



DISPENSERS



KITS



PUMPS



METERS



NOZZLES

ADD-ONS

FEATURES

- EXPANDABLE WITH DEDICATED ADD-ON
- UNLIMITED DRIVERS
- DETAILED INFO FOR EACH DRIVER
- SUITABLE FOR ALL NEED
- MONITORING AND MANAGEMENT OF THE TANKS

PIUSI B.SMART is an expandable system that quickly adapts to the new needs thanks to software-activated addons. A smart FMS that grows with the business. With the ADD-ON packages it is possible to purchase drivers accesses (5, 10 or 50) or the special function TANK WATCHDOG to have always under control the level of the fluid in the tank. You can also upgrade your MC version to B.SMART with the dedicated kit hardware 1.0/2018 upgrade.

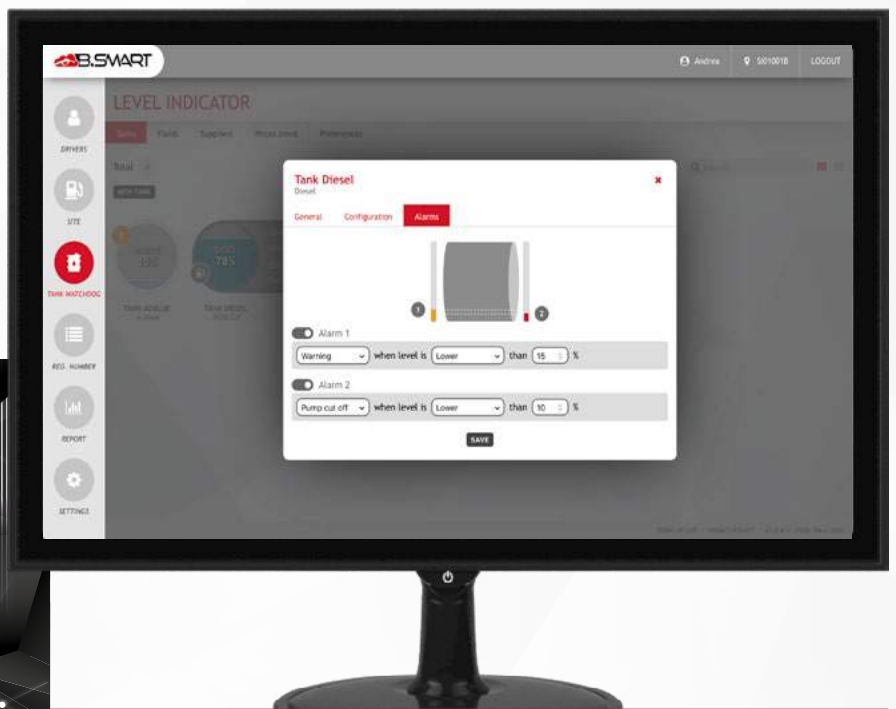

TANK WATCHDOG

- B.SMART Tank Watchdog is the perfect add on for a complete and updated control of the stock. It allows you to:
- monitor the tank level (add fluid loads and unloads and adjustments);
 - set level alarms;
 - manage suppliers;
 - follow inventory price values and trends;
 - access and download reports from anywhere.

ADD-ON

Once the ADD-ON is chosen, PIUSI will send an activation code with all related instructions.

DRIVER ADD-ON

CODE	DESCRIPTION
FO0770D00	DRIVER ACCESS ADD-ON B.SMART (X5)
FO0770D10	DRIVER ACCESS ADD-ON B.SMART (X15)
FO0770D20	DRIVER ACCESS ADD-ON B.SMART (X50)

TANK WATCHDOG ADD-ON (available from september 2020)

CODE	DESCRIPTION
FO0770L00	B.SMART TANK WATCHDOG ADD-ON - 1 YEAR
FO0770L10	B.SMART TANK WATCHDOG ADD-ON - 3 YEARS
FO0770L20	B.SMART TANK WATCHDOG ADD-ON - ONE TIME FEE

ONLY WITH THE PURCHASING OR THE PRESENCE IN THE SYSTEM OF OCIO 2.0



FILTRATION



TANK MONITORING



HOSE REEL



ACCESSORIES



MERCHANDISE

INDEX



AIR



ANTIFREEZE



AdBlue®



BIODIESEL



DIESEL



FOOD



GASOLINE



GREASE



KEROSENE



OIL



WATER



WINDSCREEN



TANK WATCHDOG - tank levels

Adding the level indicator OCIO, the system allows you to monitor the fluid level in your tanks in real time and gives alarms in case of malfunction or low levels. A perfect add on for a complete and updated control of the stock. You can connect also any 420 mA o O-10 V fluid gauge or run the system without any gauge thank to the “virtual tank” option:

- set level alarms and get notifications on the tank level;
- possibility to configure high level or low level alarms;
- stop the pump according to the level of the fluid;
- send an automatic e-mail to notify when you reach the level alarm set.

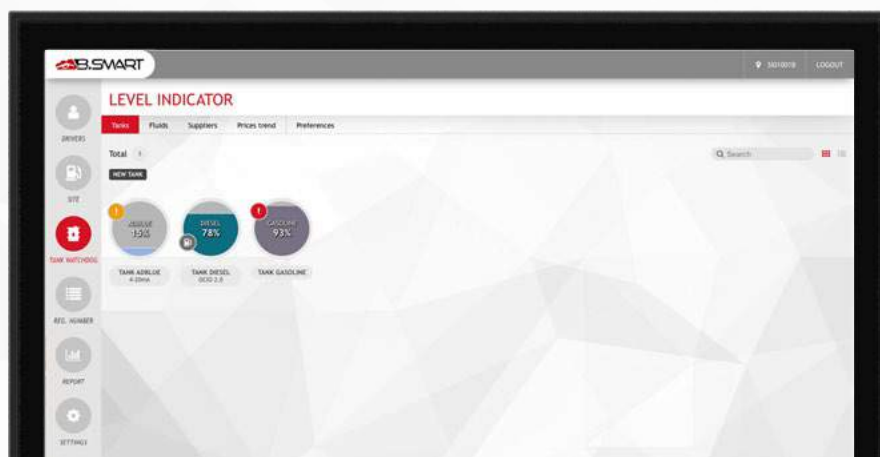

TANK WATCHDOG - fluid price and values

Thank to the level indicator OCIO you can have at your fingertips the fluid inventory value & quantity: you can define the refuelling price and verify the current inventory value.

- manage suppliers of the fluids to keep track of the date, price and quantity bought;
- get real time data of the value of your inventory;
- follow fluids price trends;
- access and download reports from any internet connected device thanks to the software cloud.

ADD-ONS



CUBE B.SMART

FEATURES

- STURDY STRUCTURE
- COMPACT DESIGN
- NATIVE WITH B.SMART CLOUD SOFTWARE
- KIT UPGRADE 1.0/2018 AVAILABLE
- IP55

The CUBE B.SMART fuel dispenser, available in the 70 and 90 litre/min versions with both AC and DC supply, is equipped with a self-priming vane pump with built-in bypass that ensures high performance. The anti-vibration support of the diesel dispenser guarantees silent operation and practicality, while the mechanical seal and the thermal protection of the induction motor against overheating make the product reliable and safe. CUBE B.SMART is equipped with an automatic nozzle with swivel connection. The installation of the mesh filter on the suction side ensures the pump longevity, as it prevents foreign bodies from ending up in the rotor and causing a blockage and consequent damage.

PERFORMANCE

UP TO 90 L/MIN FLOW RATE	AC/DC VOLTAGE POWER
± 0,5% ACCURACY	BLUETOOTH CONNECTION

NEW
Upgrade your MC hardware to B.SMART with KIT UPGRADE CUBE 1.0/2018



CUBE B.SMART



PACKAGING

CODE	WEIGHT		PACKAGING			N. BOXES / EUROPALLET	
	KG	LBS	MM	INCH	PCS/BOX	X	

AC VERSION

FO0598000	24	53	380X380X480	15,0X15,0X18,9	1	-	-
FO0598020	24	53	380X380X480	15,0X15,0X18,9	1	-	-
FO0598040	24	53	380X380X480	15,0X15,0X18,9	1	-	-
FO0598010	24	54	380X380X480	15,0X15,0X18,9	1	-	-
FO0598030	24	54	380X380X480	15,0X15,0X18,9	1	-	-
FO0598050	24	54	380X380X480	15,0X15,0X18,9	1	-	-

DC VERSION

FO0598A00	23	50	380X380X480	15,0X15,0X18,9	1	-	-
FO0598A20	23	50	380X380X480	15,0X15,0X18,9	1	-	-
FO0598A40	23	50	380X380X480	15,0X15,0X18,9	1	-	-
FO0598A10	23	50	380X380X480	15,0X15,0X18,9	1	-	-
FO0598A30	23	50	380X380X480	15,0X15,0X18,9	1	-	-
FO0598A50	23	50	380X380X480	15,0X15,0X18,9	1	-	-



FILTRATION



TANK MONITORING



HOSE REEL



ACCESSORIES



MERCHANDISE

INDEX



AIR



ANTIFREEZE



AdBlue®



BIODIESEL



DIESEL



FOOD



GASOLINE



GREASE



KEROSENE



OIL



WATER



WINDSCREEN

CHART

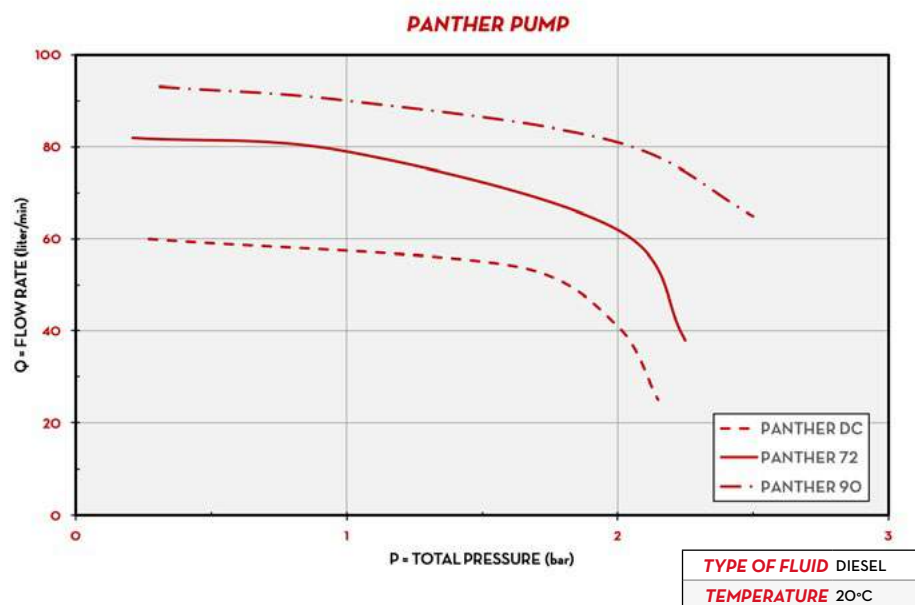

IN THE BOX

- CUBE B.SMART DISPENSER
- AUTOMATIC NOZZLE
- DELIVERY HOSE
- DRIVER ACCESS ADD-ON
- INSTRUCTION MANUAL

DETAILS



DIMENSIONS

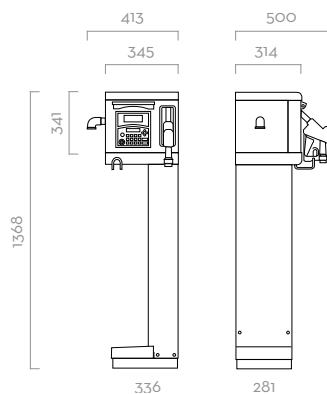

Dimensions expressed in millimeters

MATERIALS

- **PUMPS:**
PANTHER AC PAG. 102
PANTHER DC PAG. 114
- **METER:**
K600/3 PAG. 134
- **NOZZLE:**
AUTOMATIC NOZZLE PAG. 158

TECHNICAL DATA

CODE	DESCRIPTION	FLUIDS TYPE	FLOW RATE		VOLTAGE			PUMP	METER	NOZZLE	FILTER	INLET	HOSE	
			L/MIN	GPM	AC V/HZ	DC VOLT	POWER WATT						AMP. MAX.	TYPE
AC VERSION														
FO0598000	CUBE 70 230V B.SMART 10 DRIVERS	D	70	18	230 V	50 HZ	900 W	4,2 A	PANTHER 72	K600/3	A60	NO	1"	4M 25MM
FO0598020	CUBE 70 B.SMART 230 V 20 DRIVERS	D	70	18	230 V	50 HZ	900 W	4,2 A	PANTHER 72	K600/3	A60	NO	1"	4M 25MM
FO0598040	CUBE 70 B.SMART 230 V 50 DRIVERS	D	70	18	230 V	50 HZ	900 W	4,2 A	PANTHER 72	K600/3	A60	NO	1"	4M 25MM
FO0598010	CUBE 90 230V B.SMART 10 DRIVERS	D	90	24	230 V	50 HZ	900 W	4,9 A	PANTHER 90	K600/3	A120	NO	1"	4M 25MM
FO0598030	CUBE 90 B.SMART 230V 20 DRIVERS	D	90	24	230 V	50 HZ	900 W	4,9 A	PANTHER 90	K600/3	A120	NO	1"	4M 25MM
FO0598050	CUBE 90 B.SMART 230V 50 DRIVERS	D	90	24	230 V	50 HZ	900 W	4,9 A	PANTHER 90	K600/3	A120	NO	1"	4M 25MM
DC VERSION														
FO0598A00	CUBE 12 V B.SMART · 10 DRIVERS	D	56	15	12 V		300	35	PANTHER DC	K600/3	A60	NO	1"	4M 25MM
FO0598A20	CUBE 12 V B.SMART · 20 DRIVERS	D	56	15	12 V		300	35	PANTHER DC	K600/3	A60	NO	1"	4M 25MM
FO0598A40	CUBE 12 V B.SMART · 50 DRIVERS	D	56	15	12 V		300	35	PANTHER DC	K600/3	A60	NO	1"	4M 25MM
FO0598A10	CUBE 24 V B.SMART · 10 DRIVERS	D	70	18	24 V		420	25	PANTHER DC	K600/3	A60	NO	1"	4M 25MM
FO0598A30	CUBE 24 V B.SMART · 20 DRIVERS	D	70	18	24 V		420	25	PANTHER DC	K600/3	A60	NO	1"	4M 25MM
FO0598A50	CUBE 24 V B.SMART · 50 DRIVERS	D	70	18	24 V		420	25	PANTHER DC	K600/3	A60	NO	1"	4M 25MM

CUBE B.SMART



FUEL MANAGEMENT SYSTEMS



DISPENSERS



KITS



PUMPS



METERS



NOZZLES

SELF SERVICE B.SMART

FEATURES

- FUEL MANAGEMENT SYSTEM B.SMART INTEGRATED
- NO SOFTWARE INSTALLATION REQUIRED
- SUITABLE FOR FLEETS OF ALL SIZES
- REAL TIME FEEDBACK FROM ANYWHERE
- BUILT-IN FILTER
- ALL-IN-ONE EQUIPMENT
- COMPACT DESIGN
- KIT UPGRADE 1.0/2018 AVAILABLE

Top quality diesel dispenser by PIUSI, combined with the innovative B.SMART fuel management system: this is the core of the new SELF SERVICE B.SMART. A complete device specifically engineered to fit all diesel transfer needs while performing all the features of a fuel management software in terms of monitoring, controlling and managing the consumption of fuel by the fleet.

This dispenser performs: a sturdy design to ensure proper function in any working condition, a vane pump with incorporated bypass for a high flow rate (up to 90 l/min) and an oval gear meter to ensure maximum precision in measurement. An automatic nozzle with swivel connection, ergonomic and easy to handle, and a water absorption filter completes its components.

PERFORMANCE

UP TO 90 L/MIN	AC VOLTAGE
FLOW RATE	POWER
± 0,5%	BLUETOOTH
ACCURACY	CONNECTION

NEW
Upgrade your MC hardware to B.SMART with KIT UPGRADE SELF SERVICE 1.0/2018



SELF SERVICE B.SMART



PACKAGING							
CODE	WEIGHT		PACKAGING			N. BOXES / EUROPALLET	
	KG	LBS	MM	INCH	PCS/BOX	✕	
FO0748010	57	125	1480X490X400	58,3X19,3X15,7	1		
FO0748040	57	125	1480X490X400	58,3X19,3X15,7	1		
FO0748060	57	125	1480X490X400	58,3X19,3X15,7	1		
FO0748000	61	133	1480X490X400	58,3X19,3X15,7	1		
FO0748030	61	133	1480X490X400	58,3X19,3X15,7	1		
FO0748070	61	133	1480X490X400	58,3X19,3X15,7	1		



FILTRATION



TANK MONITORING



HOSE REEL



ACCESSORIES



MERCHANDISE

INDEX



AIR



ANTIFREEZE



AdBlue®



BIODIESEL



DIESEL



FOOD



GASOLINE



GREASE



KEROSENE



OIL



WATER



WINDSCREEN

CHART

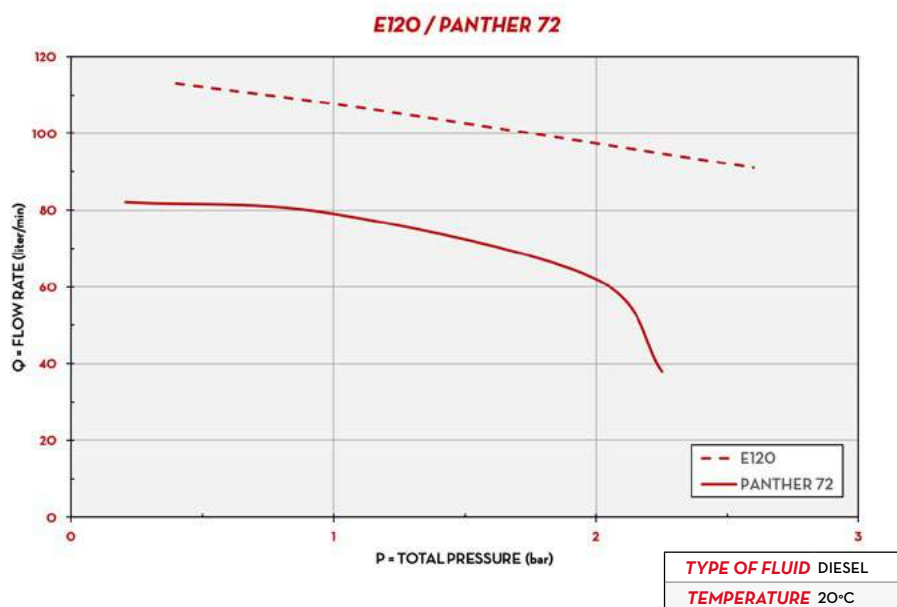

DIMENSIONS

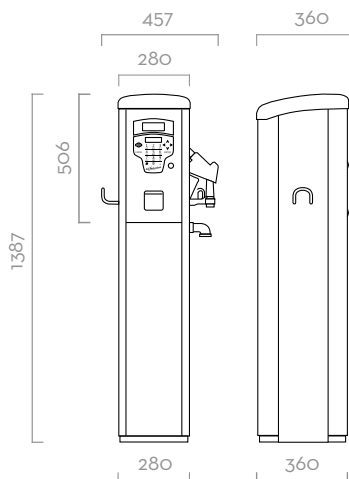

Dimensions expressed in millimeters

IN THE BOX

- SELF SERVICE B.SMART DISPENSER
- DELIVERY HOSE
- AUTOMATIC NOZZLE
- DRIVER ACCESS ADD-ON
- INSTRUCTION MANUAL

DETAILS



MATERIALS

- **PUMPS:**
PANTHER 72 / E120 PAG. 102/106
- **METER:**
K600/3 PAG. 134
- **NOZZLE:**
AUTOMATIC NOZZLE PAG. 158
- **FILTER:**
WATER CAPTOR PAG. 170

TECHNICAL DATA

CODE	DESCRIPTION	FLUIDS TYPE	FLOW RATE		VOLTAGE			PUMP	METER	NOZZLE	FILTER	INLET	HOSE		
			L/MIN	GPM	AC V./HZ	DC VOLT	POWER WATT						AMP. MAX.	LENGTH	Ø
FO0748010	SELF SERVICE 70 230V B.SMART 10 DRIVERS	D	70	18	230 V	50 HZ	550 W	3,3 A	PANTHER 72	K600/3	A120	30 µM	11/2"	4M	25MM
FO0748040	SELF SERVICE 70 230V B.SMART 20 DRIVERS	D	70	18	230 V	50 HZ	550 W	3,3 A	PANTHER 72	K600/3	A120	30 µM	11/2"	4M	25MM
FO0748060	SELF SERVICE 70 230V B.SMART 50 DRIVERS	D	70	18	230 V	50 HZ	550 W	3,3 A	PANTHER 72	K600/3	A120	30 µM	11/2"	4M	25MM
FO0748000	SELF SERVICE 100 230V B.SMART 10 DRIVERS	D	90	24	230 V	50 HZ	1150 W	5,7 A	E120	K600/3	A120	30 µM	11/2"	4M	25MM
FO0748030	SELF SERVICE 100 230V B.SMART 20 DRIVERS	D	90	24	230 V	50 HZ	1150 W	5,7 A	E120	K600/3	A120	30 µM	11/2"	4M	25MM
FO0748070	SELF SERVICE 100 230V B.SMART 50 DRIVERS	D	90	24	230 V	50 HZ	1150 W	5,7 A	E120	K600/3	A120	30 µM	11/2"	4M	25MM

SELF SERVICE B.SMART



MCBOX B.SMART

FEATURES

- IDEALS FOR EXISTING PLANTS
- SUITABLE FOR ANY PUMPS
- PULSE METER INPUT
- NATIVE WITH B.SMART CLOUD SOFTWARE

MCBOX is an electronic control panel that allows you to control any type of AC/DC pump, pulser litre-counter, nozzle and fuel level switches. The perfect product to upgrade an existing installation or for a customized assembly. With MC BOX B.SMART the B.SMART fuel management system is integrated. No need for software to be installed on a PC: B.SMART works in the Cloud and allows you to monitor all fuel transactions in real time, from any site where MCBOX B.SMART is installed. Communication between MCBOX B.SMART, Phone App and Cloud Software is simple.

PERFORMANCE

AC/DC

VOLTAGE

POWER

UP TO

500

STORABLE

TRANSACTIONS

**2 PUMPS
VERSION**

OUTPUT

BLUETOOTH

CONNECTION



MC BOX B.SMART



PACKAGING

CODE	WEIGHT		PACKAGING			N. BOXES / EUROPALLET	
	KG	LBS	MM	INCH	PCS/BOX	X	

AC VERSIONS

FO0599000	5,2	11,5	300X300X180	11.8X11.8X7.1	1	-	-
FO0599040	5,2	11,5	300X300X180	11.8X11.8X7.1	1	-	-
FO0599080	5,2	11,5	300X300X180	11.8X11.8X7.1	1	-	-
FO0599200	5,3	11,6	300X300X180	11.8X11.8X7.1	1	-	-
FO0599240	5,3	11,6	300X300X180	11.8X11.8X7.1	1	-	-
FO0599280	5,3	11,6	300X300X180	11.8X11.8X7.1	1	-	-

DC VERSIONS

FO0599010	5,4	11,8	300X300X180	11.8X11.8X7.1	1	-	-
FO0599050	5,4	11,8	300X300X180	11.8X11.8X7.1	1	-	-
FO0599090	5,4	11,8	300X300X180	11.8X11.8X7.1	1	-	-
FO0599060	5,4	11,8	300X300X180	11.8X11.8X7.1	1	-	-
FO0599070	5,4	11,8	300X300X180	11.8X11.8X7.1	1	-	-
FO0599110	5,4	11,8	300X300X180	11.8X11.8X7.1	1	-	-



FILTRATION



TANK MONITORING



HOSE REEL



ACCESSORIES



MERCHANDISE

INDEX



AIR



ANTIFREEZE



AdBlue®



BIODIESEL



DIESEL



FOOD



GASOLINE



GREASE



KEROSENE



OIL



WATER



WINDSCREEN

CONNECTION SCHEME



PUMP CONTROL



PULSE METER INPUT



TANK LEVEL INDICATOR



NOZZLE SWITCH



IN THE BOX

- MCBOX B.SMART UNIT
- DRIVER ACCESS ADD-ON
- INSTRUCTION MANUAL

DETAILS



SHUTTER



B.SMART MOBILE APP



B.SMART CLOUD SOFTWARE



EASY ACCESS TO CONNECTION

DIMENSIONS

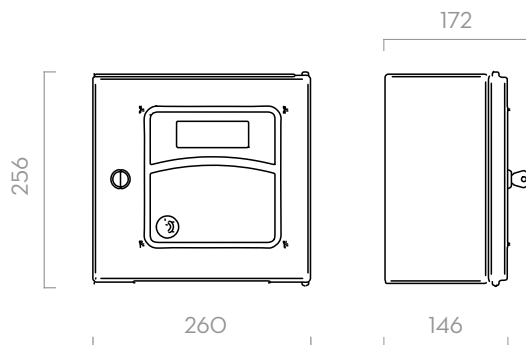

Dimensions expressed in millimeters

TECHNICAL DATA

CODE	DESCRIPTION	FLUIDS TYPE	VOLTAGE				B.SMART CLOUD
			AC V./HZ DC VOLT	50/60 HZ	POWER WATT	AMP. MAX.	
AC VERSIONS							
FO0599000	MCBOX 100-240V B.SMART 10 DRIVERS	ANY	100V-240V	50/60 HZ	5W	15 A	INCLUDED
FO0599040	MCBOX 100-240V B.SMART 20 DRIVERS	ANY	100V-240V	50/60 HZ	5W	15 A	INCLUDED
FO0599080	MCBOX 100-240V B.SMART 50 DRIVERS	ANY	100V-240V	50/60 HZ	5W	15 A	INCLUDED
FO0599200	MCBOX 100-240V B.SMART 10 DRIVERS 2 PUMPS	ANY	100V-240V	50/60 HZ	5W	15 A	INCLUDED
FO0599240	MCBOX 100-240V B.SMART 20 DRIVERS 2 PUMPS	ANY	100V-240V	50/60 HZ	5W	15 A	INCLUDED
FO0599280	MCBOX 100-240V B.SMART 50 DRIVERS 2 PUMPS	ANY	100V-240V	50/60 HZ	5W	15 A	INCLUDED
DC VERSIONS							
FO0599010	MCBOX 12V B.SMART 10 DRIVERS	ANY	12 V	-	5W	50 A	INCLUDED
FO0599050	MCBOX 12V B.SMART 20 DRIVERS	ANY	12 V	-	5W	50 A	INCLUDED
FO0599090	MCBOX 12V B.SMART 50 DRIVERS	ANY	12 V	-	5W	50 A	INCLUDED
FO0599060	MCBOX 24V B.SMART 10 DRIVERS	ANY	24 V	-	5W	25 A	INCLUDED
FO0599070	MCBOX 24V B.SMART 20 DRIVERS	ANY	24 V	-	5W	25 A	INCLUDED
FO0599110	MCBOX 24V B.SMART 50 DRIVERS	ANY	24 V	-	5W	25 A	INCLUDED

MCBOX B.SMART



SSM2.0

FEATURES

- TANK WATCHDOG
- DRIVERS/VEHICLES MANAGEMENT
- REPORT
- SSM 2.0 CLOUD READY
- FLUID INVENTORY VALUE

The new SELF SERVICE MANAGEMENT 2.0 software is the most advanced response for management and monitoring of refueling, allowing supervision of drivers, vehicles and fuel tanks. Setting up the system and getting to work has never been easier: simply connect the devices to your LAN or Wi-Fi network and click on the "Detect System" button on your PC. SELF SERVICE MANAGEMENT 2.0 will handle the rest. Use of the SELF SERVICE MANAGEMENT 2.0 software requires the new range of SELF SERVICE 2.0 dispensing devices. The ibutton key reader kit is available on request.

PERFORMANCE

UP TO
1000

DIVERS / VEHICLES

USB/WEB

SOFTWARE VERSION
INSTALLATION

SOFTWARE ACTIVATION MODE



**USB
HARDWARE KEY**
without internet
connection



**WEB
EDITION**
internet connection
required





FILTRATION



TANK MONITORING



HOSE REEL



ACCESSORIES



MERCHANDISE

INDEX



AIR



ANTIFREEZE



AdBlue®



BIODIESEL



DIESEL



FOOD



GASOLINE



GREASE



KEROSENE



OIL



WATER



WINDSCREEN

CHECK

The cost of the consumption for every distance.



VIEW

Bar charts easily allow you to analyze the liters delivered each day and compare them with the average use.

VEHICLES

Reads the average consumption and distance driven.



TANK MONITORING

Check the liters delivered over the period you specify.



The system min. requirements are:

- Monitor resolution 1280x700
- CPU: Intel® Pentium® 4 or AMD Athlon® 64 processor (2 GHz or higher)
- RAM: 2 GB
- Free space on Hard Disk: 20 GB
- Operating system: Windows VISTA SP2, Windows Server 2008 R2 SP1, Windows 7 SP1, Windows 8, Windows 8.1, Windows Server 2012, Windows Server 2012 R2, Windows 10
- Database: Microsoft SQL 2012 R2 SP2 Express (included in the installation)

TECHNICAL DATA - USB CODE

CODE	DESCRIPTION
FO0772050	SSM 2.0 ENTRY
FO077202A	SSM 2.0 ADVANCED
FO077204A	SSM 2.0 SUITE
FO0772000	SSM 2.0 CLIENT

TECHNICAL DATA - WEB CODE

CODE	DESCRIPTION
FO0772250	SSM 2.0 ENTRY - WEB EDITION
FO077222A	SSM 2.0 ADVANCED - WEB EDITION
FO077224A	SSM 2.0 SUITE - WEB EDITION
FO0772200	SSM 2.0 CLIENT - WEB EDITION

THE PURCHASE OF ADDITIONAL CLIENT LICENSES ENABLES YOU TO USE THE VARIOUS VERSIONS OF SELF SERVICE MANAGEMENT 2.0 ON MULTIPLE WORKSTATIONS.

SSM2.0



DATA TRANSFER SSM2.0

Among the equipment related to SSM 2.0, PIUSI has developed a set of technological solutions able to connect the electronic/mechanical device to the fluid control system, that is the software that organizes the operation of the hardware; in this case SELF SERVICE MANAGEMENT 2.0. How does data transfer with SSM2.0 work? It depends on the technology required.

Direct downloading

Use your Manager Key to transfer the data from dispenser to PC: it is enough to touch the dispenser with the key and then use the key reader to transfer the data collected.

LAN/Wi-Fi

The way to receive in real time all information regarding the transactions: using PWLAN or PW WiFi the software recognizes the fuel dispensers and it will automatically send the data to the SELF SERVICE MANAGEMENT 2.0 software.

Mobile Network

The brand-new PW MOBILE 4G 2.0 allows to install dispenser wherever desired, even in the most remote area, without the need of a local network: the device uses the mobile 4G technology to communicate and transfer data and comes with a SIM card included.





FILTRATION



TANK MONITORING



HOSE REEL



ACCESSORIES



MERCHANDISE

INDEX



AIR



ANTIFREEZE



AdBlue®



BIODIESEL



DIESEL



FOOD



GASOLINE



GREASE



KEROSENE



OIL



WATER



WINDSCREEN

PW MOBILE



A new communication system that allows you to transfer data using mobile 4G network.

KEY READER & MANAGER KEY 2.0



LAN



A network card that allows the RS485 signal to be converted for connection to a LAN, through a simple and intuitive interface.

PW WI-FI



A device that allows to convert the RS485 signal to Wi-Fi, through a simple and intuitive interface.

cable max 90 mt

TECHNICAL DATA

CODE	DESCRIPTION
F1226201A	KIT KEY READER SELF SERVICE 2.0
F20552010	MANAGER KEY 2.0 (GREY)
F1271012A	PW WI-FI 2.0
F12710130	PW MOBILE 4G 2.0

DATA TRANSFER SSM2.0



SSM2.0 CLOUD

FEATURES

- DATA ALWAYS AVAILABLE
- NO INSTALLATION REQUIRED ON THE PC
- MANAGE SEVERAL SITES AT THE SAME TIME

PIUSI SSM 2.0 CLOUD is the application that lets you control your refueling sites remotely and manage several installations at the same time. With SSM 2.0 CLOUD you can fully monitor the equipment of each site, manage vehicles and drivers, have an overview of the situation of your plants at a glance and filter all data. Information are always available everywhere and at any time thus stored in Cloud.

 **SSM2.0 CLOUD**[®]



PERFORMANCE

6 MONTHS

FREE TRIAL

TRY&BUY

AVAILABLE DATA
STORAGE

ANYWHERE ANYTIME

DATA BACKUP

INFO &
CONSUMPTION

MONITORING

DRIVERS&VEHICLE

TANK LEVEL

MONITORING

TANK WATCHDOG



NEW

TRY & BUY

SSM 2.0 CLOUD is now available in the TRY & BUY mode: a free 6-month trial of the CLOUD service made available by PIUSI, which allows you to manage your system from any device or tablet.

Once the free 6-month trial has ended, you can proceed with the purchase keeping in cloud the data used during the trial period.

Ask your dealer for further details!



FILTRATION



TANK MONITORING



HOSE REEL



ACCESSORIES



MERCHANDISE

INDEX



AIR



ANTIFREEZE



AdBlue®



BIODIESEL



DIESEL



FOOD



GASOLINE



GREASE



KEROSENE



OIL



WATER



WINDSCREEN

TANK WATCHDOG

The tank watchdog section allows you to manage the level of all your tanks, mono or multi-site installations.

DASHBOARD

The core of the system. Choose to display the time range you are interested in, group and filter by consumption, dispensing, and levels.

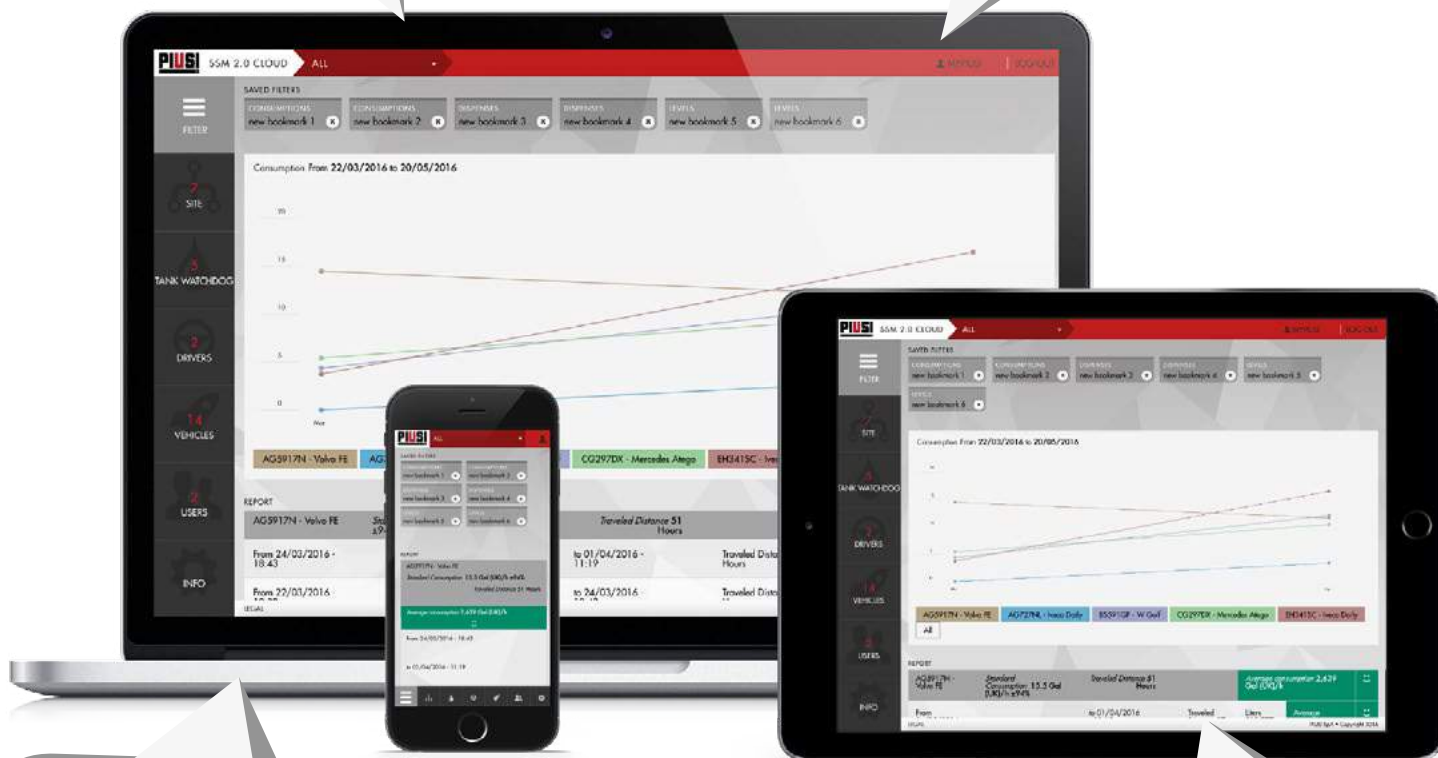

DIVERS&VEHICLES

Add, modify and monitor the main information of each vehicle and driver for each of your sites.

DATA BACKUP

Thanks to SSM 2.0 CLOUD all your data are always backed-up and available anywhere and any time you need, also in case of PC malfunction.

SITE

Access the "site" section for an overview of all your sites and installed devices.



CUBE MC 2.0

FEATURES

- STURDY STRUCTURE
- BUILT-IN LAN ADAPTER
- COMPACT DESIGN
- SSM 2.0 SOFTWARE REQUIRED
- IP55
- IDEAL FOR FUEL MANAGEMENT

The PIUSI CUBE MC 2.0 is the perfect solution for those who need safe and simple, high-volume fuel dispensing operations while checking transactions and managing their own fleet. The system is equipped with the same main feature of the CUBE MC, and includes a built-in LAN connection. SSM 2.0 Software required.

PERFORMANCE

UP TO
90 L/MIN

FLOW RATE

UP TO
1000

USERS

± 0,5%

ACCURACY



CUBE MC 2.0



CUBE MC 2.0 WITH PEDESTAL (OPTIONAL)

PACKAGING

CODE	WEIGHT		PACKAGING			N. BOXES / EUROPALLET	
	KG	LBS	MM	INCH	PCS/BOX	✕	
FO059600B	25	55	400X400X460	-	1	12	24
FO059610B	25	55	400X400X460	-	1	12	24



FILTRATION



TANK MONITORING



HOSE REEL



ACCESSORIES



MERCHANDISE

INDEX



AIR



ANTIFREEZE



AdBlue®



BIODIESEL



DIESEL



FOOD



GASOLINE



GREASE



KEROSENE



OIL



WATER



WINDSCREEN

CHART

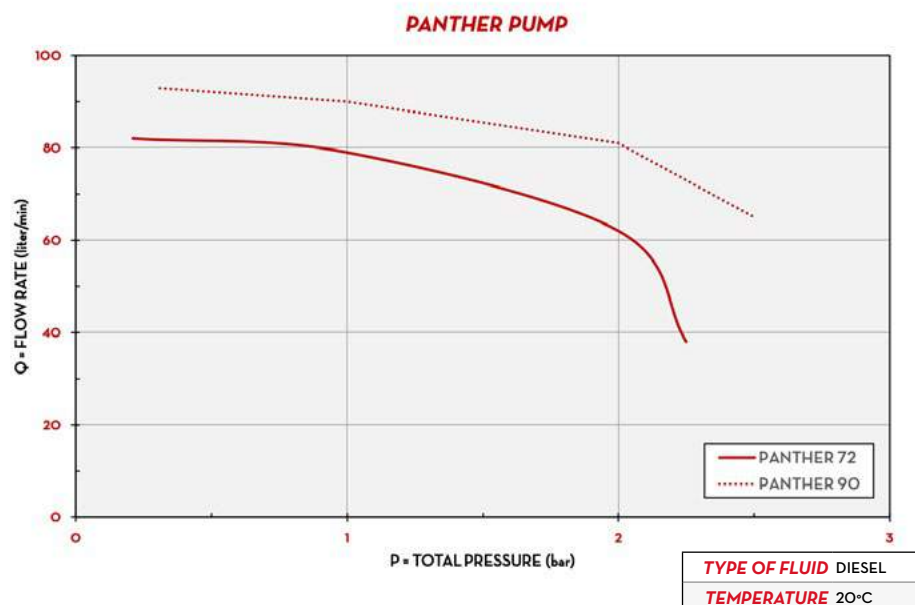

DIMENSIONS

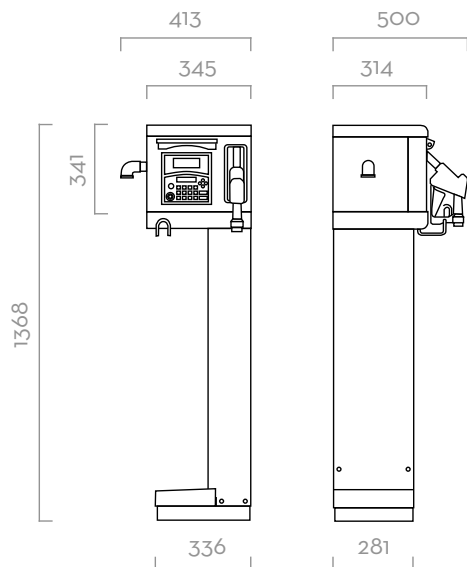

Dimensions expressed in millimeters

IN THE BOX

- CUBE MC 2.0 DISPENSER
- AUTOMATIC NOZZLE
- DELIVERY HOSE
- INSTRUCTION MANUAL

DETAILS



SHUTTER



USER&VEHICLE KEY (n.i.)



SSM 2.0 SOFTWARE (pag. 28)



DATA TRANSFER SSM2.0 (pag. 30)

MATERIALS

- **PUMPS:**
PANTHER AC PAG. 102
PANTHER DC PAG. 114
- **METER:**
K600/3 PAG. 135
- **NOZZLE:**
AUTOMATIC NOZZLE PAG. 158

TECHNICAL DATA

CODE	DESCRIPTION	FLUIDS TYPE	FLOW RATE		VOLTAGE			PUMP	METER	NOZZLE	FILTER	INLET	HOSE LENGTH	SELF SERVICE MANAGEMENT 2.0	
			L/MIN	GPM	AC V./HZ	DC VOLT	POWER WATT								AMP. MAX.
FO059600B	CUBE 70 MC 2.0	D	70	18	230/50		900	4,9	PANTH 72	K600	A60	NO	1"	4	REQUIRED
FO059610B	CUBE 90 MC 2.0	D	90	23,8	230/50		900	4,9	PANTH 90	K600	A120	NO	1"	4	REQUIRED

CUBE MC 2.0



SELF SERVICE MC 2.0

FEATURES

- STURDY STRUCTURE
- ALL-IN-ONE DISPENSER
- BUILT-IN LAN ADAPTER
- FRONT DOOR FOR EASY MAINTENANCE
- SSM 2.0 SOFTWARE REQUIRED
- IP55
- IDEAL FOR FUEL MANAGEMENT

The PIUSI SELF SERVICE MC 2.0 is a non-commercial fuel diesel dispenser able to fit any fleet management requirement. It requires the SSM 2.0 software to work. Equipped with 90 l/min continuous duty pump, it is suitable for any fleet dimension.

PERFORMANCE

UP TO 90 L/MIN	AC CONTINUOUS DUTY
FLOW RATE	POWER
± 0,5%	UP TO 1000
ACCURACY	USERS



ELECTRONIC METER INTEGRATED



SELF SERVICE MC 2.0

PACKAGING

CODE	WEIGHT		PACKAGING			N. BOXES / EUROPALLET	
	KG	LBS	MM	INCH	PCS/BOX	✈	🚚

COLUMN VERSION

FO074302B	75	165	1478X488X400	-	1	6	4
-----------	----	-----	--------------	---	---	---	---



FILTRATION



TANK MONITORING



HOSE REEL



ACCESSORIES



MERCHANDISE

INDEX



AIR



ANTIFREEZE



AdBlue®



BIODIESEL



DIESEL



FOOD



GASOLINE



GREASE



KEROSENE



OIL



WATER



WINDSCREEN

CHART

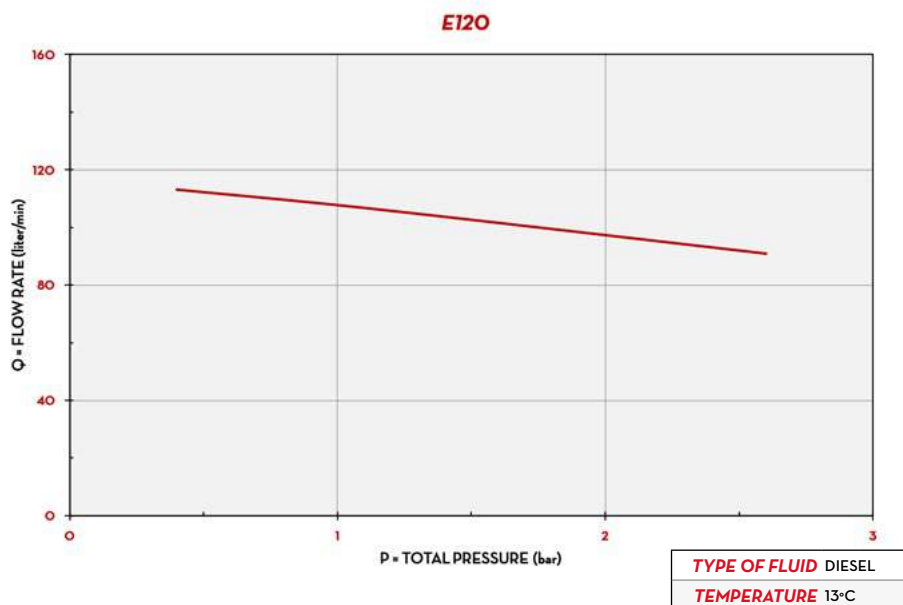

IN THE BOX

- SELF SERVICE MC 2.0 DISPENSER
- DELIVERY HOSE
- AUTOMATIC NOZZLE
- INSTRUCTION MANUAL

DETAILS



WATER CAPTOR FILTER (pag. 170)



DRIVER&VEHICLE KEY (n.i.)



SSM 2.0 SOFTWARE (pag. 28)



DATA TRANSFER SSM2.0 (pag. 30)

DIMENSIONS

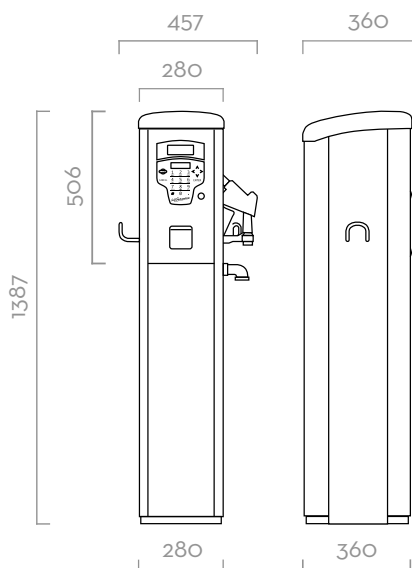

Dimensions expressed in millimeters

MATERIALS

- **PUMPS:**
E80 / E120 PAG. 106
- **METER:**
K600/3 PAG. 134
- **NOZZLE:**
AUTOMATIC NOZZLE PAG. 158
- **FILTER:**
WATER CAPTOR PAG. 170

TECHNICAL DATA

CODE	DESCRIPTION	FLUIDS TYPE	FLOW RATE		VOLTAGE			PUMP	METER	NOZZLE	FILTER		INLET	HOSE LENGTH	SELF SERVICE MANAGEMENT 2.0
			L/MIN	GPM	AC V./HZ DC VOLT	POWER WATT	AMP. MAX.				H2O FILTER	FILTERING CAPACITY			

COLUMN VERSIONS

FO074302B	SELF SERVICE 100 MC 2.0	D	90	24	230/50	1150	5,7	E120	K600	A120	YES	30µ	1" 1/2	4	REQUIRED
-----------	-------------------------	----------	----	----	--------	------	-----	------	------	------	-----	-----	--------	---	----------

SELF SERVICE MC 2.0



SELF SERVICE FM 2.0

FEATURES

- IDEAL FOR FUEL MANAGEMENT
- TANK LEVEL INDICATOR
- TICKET PRINTER
- MULTI-USER MANAGEMENT
- STURDY STRUCTURE
- EASY MAINTENANCE
- HIGH DISPLACEMENT VANE PUMP
- SSM 2.0 SOFTWARE REQUIRED
- IP55

The PIUSI SELF SERVICE FM 2.0 is the top-level, all-in-one dispenser for fuel with integrated LAN connection to guarantee continuous communication between dispenser and PC, water captor filter to ensure the highest purity of fluids, OCIO 2.0 tank level indicator and an electronic panel able to manage up to 1000 users and 650 transactions. Compatible with SSM 2.0 software.

PERFORMANCE

UP TO 90 L/MIN	AC CONTINUOUS DUTY
FLOW RATE	POWER
± 0,5%	UP TO 1000
ACCURACY	USERS



INTEGRATED TICKET PRINTER



SELF SERVICE FM 2.0

PACKAGING

CODE	WEIGHT		PACKAGING			N. BOXES / EUROPALLET	
	KG	LBS	MM	INCH	PCS/BOX	✈	🚚

COLUMN VERSION

FO074301A	75	165	1478X488X400	-	1	6	4
-----------	----	-----	--------------	---	---	---	---



FILTRATION



TANK MONITORING



HOSE REEL



ACCESSORIES



MERCHANDISE

INDEX



AIR



ANTIFREEZE



AdBlue®



BIODIESEL



DIESEL



FOOD



GASOLINE



GREASE



KEROSENE



OIL



WATER



WINDSCREEN

CHART

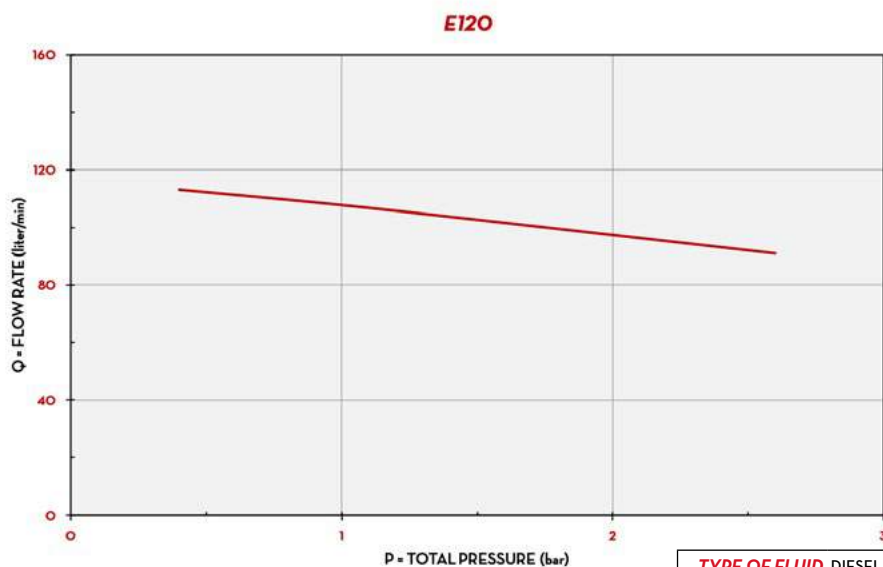

TYPE OF FLUID DIESEL
TEMPERATURE 13°C

DIMENSIONS

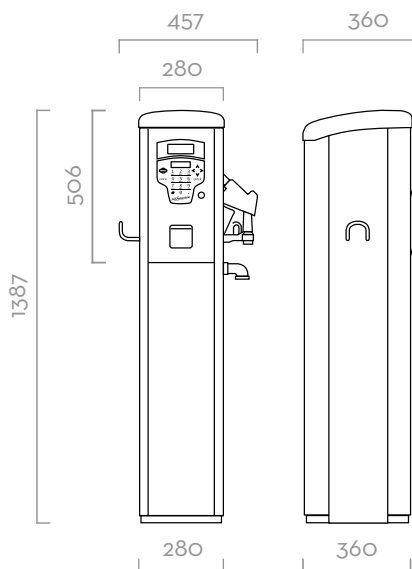

Dimensions expressed in millimeters

IN THE BOX

- SELF SERVICE FM 2.0 DISPENSER
- DELIVERY HOSE
- AUTOMATIC NOZZLE
- INSTRUCTION MANUAL

DETAILS



MATERIALS

- **PUMP:**
E120 PAG. 106
- **METER:**
K600/3 PAG. 134
- **NOZZLE:**
AUTOMATIC NOZZLE PAG. 158
- **FILTER:**
WATER CAPTOR PAG. 170

TECHNICAL DATA

CODE	DESCRIPTION	FLUIDS TYPE	FLOW RATE		VOLTAGE			PUMP	METER	NOZZLE	FILTER		INLET	HOSE LENGTH METERS	SELF SERVICE MANAGEMENT 2.0
			L/MIN	GPM	AC V/ HZ DC VOLT	POWER WATT	AMP. MAX.				H2O FILTER	FILTERING CAPACITY			

COLUMN VERSIONS

FO074301A	SELF SERVICE 100 FM 2.0	D	90	24	230/50	1150	5,7	E120	K600	A120	YES	30µ	1" 1/2	4	REQUIRED
-----------	-------------------------	----------	----	----	--------	------	-----	------	------	------	-----	-----	--------	---	----------

SELF SERVICE FM 2.0



FUEL MANAGEMENT SYSTEMS



DISPENSERS



KITS



PUMPS



METERS



NOZZLES

MCBOX 2.0

FEATURES

- FLEET MANAGEMENT
- SUITABLE FOR ANY PUMP
- PULSE METER INPUT
- LAN/WI-FI VERSION AVAILABLE
- SSM2.0 SOFTWARE REQUIRED

The PIUSI MCBOX 2.0 is the evolution of the MCBOX system thanks to the integration with the 2.0 features: fuel consumption monitoring and report, fleet management, vehicles and users control. It is suitable to manage and control an existing pump, pulse meter and nozzle.

PERFORMANCE

UP TO
1000

USERS / VEHICLES

AC
VOLTAGE
POWER



MC BOX 2.0



PACKAGING

CODE	WEIGHT		PACKAGING		
	KG	LBS	MM	INCH	PCS/BOX
FO059701A	6	13,2	300X300X330	11,8X11,8X13	1
FO059702A	6	13,2	300X300X330	11,8X11,8X13	1



FILTRATION



TANK MONITORING



HOSE REEL



ACCESSORIES



MERCHANDISE

INDEX



AIR



ANTIFREEZE



AdBlue®



BIODIESEL



DIESEL



FOOD



GASOLINE



GREASE



KEROSENE



OIL



WATER



WINDSCREEN

CONNECTION SCHEME



IN THE BOX

- MCBOX 2.0 UNIT
- LAN or WI-FI ADAPTER
- INSTRUCTION MANUAL

DETAILS



EASY ACCESS TO CONNECTION



USER&VEHICLE KEY



SSM 2.0 SOFTWARE (pag. 28)



SHUTTER

DIMENSIONS

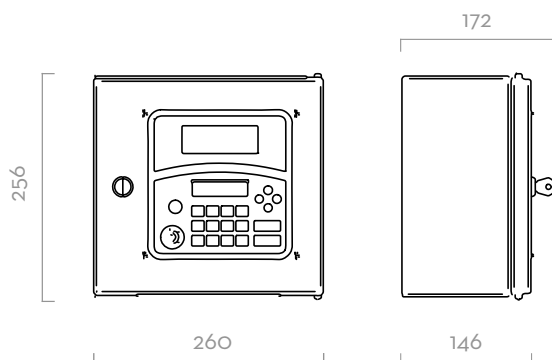

Dimensions expressed in millimeters

TECHNICAL DATA

CODE	DESCRIPTION	FLUIDS TYPE	CONNECTION	VOLTAGE			SSM 2.0 SOFTWARE
				AC V./HZ	POWER WATT	AMP. MAX. (load motor)	
FO059701A	MCBOX LAN 2.0 90-240V 50/60HZ	A Ad B D F G G K O W W	LAN	12	10	50	REQUIRED
FO059702A	MCBOX 2.0 WIFI 90-240V 50/60HZ	A Ad B D F G G K O W W	WI-FI	24	10	25	REQUIRED

MCBOX 2.0



SSM2018

FEATURES

- **USERS MANAGEMENT**
- **EASY TO INSTALL**
- **TRANSACTION REPORT**

The new SELF SERVICE MANAGEMENT 2018 interface answers once more to the needs you've always had. But better. More intuitively, definitely more attractively and more flexibly. What PIUSI offers you is the possibility of continuing to work with the SELF SERVICE MANAGEMENT 1.0 range, but giving you more potential and more efficiency. Because new doesn't mean hard to understand.

PERFORMANCE

UP TO

16

DISPENSERS

USB/WEB

SOFTWARE VERSION

INSTALLATION

SOFTWARE ACTIVATION MODE



**USB
HARDWARE KEY**
without internet
connection



**WEB
EDITION**
internet connection
required



Software for managing reports and configuring dispensing operations.



1
ADMINISTER
THE SITE

2
PROCESS
THE REPORTS

3
CONFIGURE
SSM2018



FILTRATION



TANK MONITORING



HOSE REEL



ACCESSORIES



MERCHANDISE

INDEX



AIR



ANTIFREEZE



AdBlue®



BIODIESEL



DIESEL



FOOD



GASOLINE



GREASE



KEROSENE



OIL



WATER



WINDSCREEN



MANAGE

Select or delete the device from your system.



The system min. requirements are:

- Monitor resolution 1280-700
- CPU: Intel® Pentium® 4 or AMD Athlon® 64 processor (2 GHz or higher)
- RAM: 2 GB
- Free space on Hard Disk: 20 GB
- Operating system: Windows VISTA SP2, Windows 7 SP1, Windows 8, Windows 8.1, Windows 10
- Database: Microsoft SQL 2012 R2 SP2 Express (included in the installation)

CHOOSE

Dates, devices, drivers you want a report on.



EXPORT

Your data in the file format you prefer.

TECHNICAL DATA

CODE	DESCRIPTION
FO0773010	SELF SERVICE MANAGEMENT 2018 - USB
FO0773210	SELF SERVICE MANAGEMENT 2018 - WEB

SSM2018



DATA TRANSFER SSM2018

DATA TRANSFER SSM 2018 is a set of different solutions that let to download the transactions from the dispensers to the SELF SERVICE MANAGEMENT 2018 software. The great variety of the offer is based on the technology required.

Manual download

The easiest way to download the informations is through the Manager key 2018, it is enough to touch the dispenser with the key to transfer all the transactions and download them on the software.

Local network

Use the local network Lan/Wi-Fi to download the dispenser to your pc. By choosing between the PWLAN or PW Wi-Fi it is possible to set up a connection that let you receive all the transactions in real time.

Mobile network

Thanks to the new PW MOBILE 4G 2018 is now possible to install all the dispensers everywhere in the world with just the need of a mobile network coverage, avoiding all the local network configurations. The equipment is provided with a worldwide SIM card which makes the PWMOBILE 4G 2018 ready to use.



PW14 / RS 485



MANAGER KEY



PW-LAN

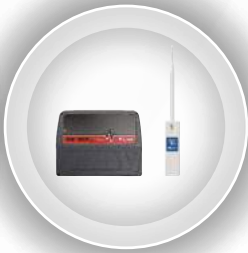

PW-WIFI



PW-MOBILE





FILTRATION



TANK MONITORING



HOSE REEL



ACCESSORIES



MERCHANDISE

INDEX



AIR



ANTIFREEZE



AdBlue®



BIODIESEL



DIESEL



FOOD



GASOLINE



GREASE



KEROSENE



OIL



WATER



WINDSCREEN

PW14 / RS 485



Connection via RS485 cable with USB converter.

KEY READER & MANAGER KEY



PW LAN



A device that allows to convert the RS485 signal to LAN, through a simple and intuitive interface.

PW WI-FI



A device that allows to convert the RS485 signal to Wi-Fi, through a simple and intuitive interface.

PW MOBILE



A new communication system that allows you to transfer data using mobile 4G network.

TECHNICAL DATA

CODE	DESCRIPTION
F13292000	PW 14
F1226201A	KIT KEY READER
F1249600A	MANAGER KEY (RED)
F1271005A	PW-LAN
F1271004B	PW-WIFI
F12710150	PW MOBILE 4G 2018

DATA TRANSFER SSM2018



FUEL MANAGEMENT SYSTEMS



DISPENSERS



KITS



PUMPS



METERS



NOZZLES

CUBE MC

FEATURES

- MULTI-USER MANAGEMENT
- ALL-IN-ONE EQUIPMENT
- COMPACT DESIGN
- COMPATIBLE WITH SSM 2018 SOFTWARE
- SUCTION FILTER
- IP55

The PIUSI CUBE MC is the upgraded version of the world famous CUBE dispenser equipped with an electronic panel able to manage up to 120 users and 255 transactions. The sturdy structure includes a self-priming vane pump, built-in bypass, automatic nozzle, and integrated nozzle holder with start/stop pump lever.

PERFORMANCE

UP TO
70 L/MIN

FLOW RATE

AC/DC
VOLTAGE

POWER

± 0,5%

ACCURACY

UP TO
120

USERS



CUBE 70 MC



CUBE 70 MC WITH PEDESTAL (OPTIONAL)

PACKAGING

CODE	WEIGHT		PACKAGING			N. BOXES / EUROPALLET	
	KG	LBS	MM	INCH	PCS/BOX	✕	🚛
FO059400D	25	55	400X400X460	-	1	12	24
FO059413C	25	55	400X400X460	-	1	12	24
FO059414C	25	55	400X400X460	-	1	12	24
FO059415C	25	55	400X400X460	-	1	12	24
FO059422A	25	55	400X400X460	-	1	12	24



FILTRATION



TANK MONITORING



HOSE REEL



ACCESSORIES



MERCHANDISE

INDEX



AIR



ANTIFREEZE



AdBlue®



BIODIESEL



DIESEL



FOOD



GASOLINE



GREASE



KEROSENE



OIL



WATER



WINDSCREEN

CHART

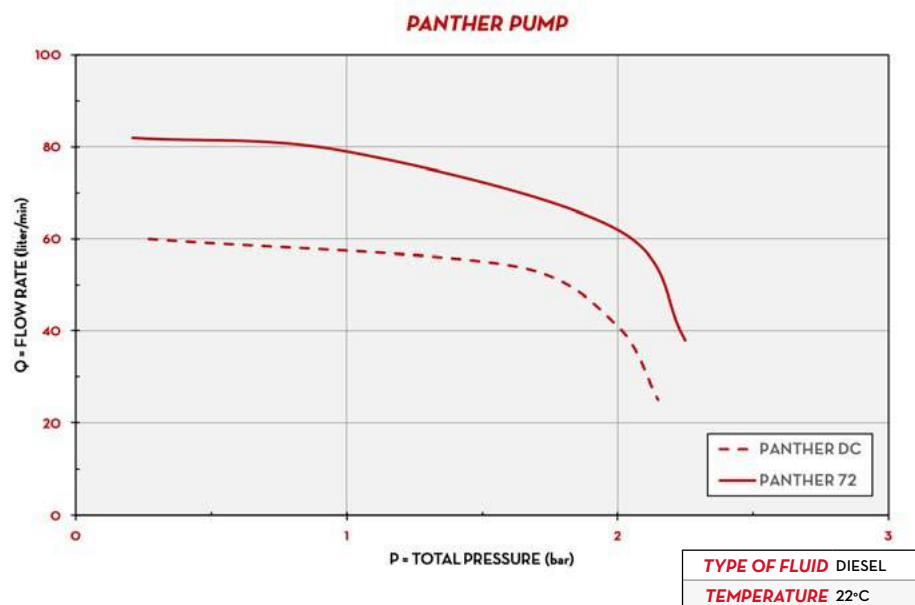

DIMENSIONS

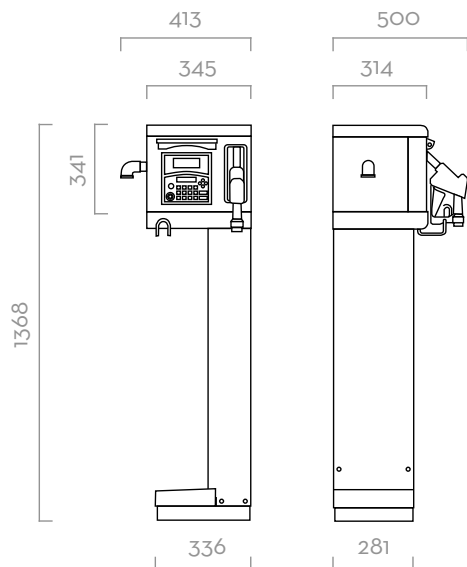

Dimensions expressed in millimeters

IN THE BOX

- CUBE MC DISPENSER
- AUTOMATIC NOZZLE
- DELIVERY HOSE
- INSTRUCTION MANUAL

DETAILS



DATA TRANSFER 2018 (pag. 44)



SSM 2018 SOFTWARE (pag. 44)

MATERIALS

- **PUMPS:**
 PANTHER AC PAG. 102
 PANTHER DC PAG. 114
- **METER:**
 K600/3 PAG. 134
- **NOZZLE:**
 AUTOMATIC NOZZLE PAG. 158

TECHNICAL DATA

CODE	DESCRIPTION	FLUIDS TYPE	FLOW RATE		VOLTAGE			PUMP TYPE	METER TYPE	NOZZLE TYPE	FILTER H2O FILTER	INLET BSP	HOSE		PC CONNECTION		USERS N°
			L/MIN	GPM	AC V/HZ DC VOLT	POWER WATT	AMP. MAX.						LENGTH	Ø	CONNECTION	N°	
FO059400D	CUBE 70 MC	D	70	18	230/50	900	4,2	PANTH 72	K600	A60	NO	1"	4M	1"	YES	50	
FO059413C	CUBE 70 MC DC 12V	D	56	15	12	300	35	PANTH DC	K600	A60	NO	1"	4M	1"	YES	50	
FO059414C	CUBE 70 MC DC 24V	D	70	18	24	420	25	PANTH DC	K600	A60	NO	1"	4M	1"	YES	50	
FO059415C	CUBE 70 MC 120 UT	D	70	18	230/50	550	3,3	PANTH 72	K600	A60	NO	1"	4M	1"	YES	120	
FO059422A	CUBE 70 MC 12V 120 UT	D	56	15	12	300	35	PANTH DC	K600	A60	NO	1"	4M	1"	YES	120	

UPON REQUEST IT IS AVAILABLE WITH DIFFERENT VOLTAGES AND 60 HZ FREQUENCY

CUBE MC



SELF SERVICE MC

FEATURES

- MULTI-USER MANAGEMENT
- WATER CAPTOR FILTER
- ALL-IN-ONE EQUIPMENT
- COMPACT DESIGN
- COMPATIBLE WITH SSM 2018 SOFTWARE
- IP55

The PIUSI SELF SERVICE MC is a complete device suitable to fit all diesel dispensing needs. With its sturdy structure, this dispenser is equipped with a high capacity vane pump, built-in bypass, automatic nozzle, water captor filter and electronic panel able to manage up to 80 users and 255 transactions.

PERFORMANCE

UP TO 90 L/MIN	AC CONTINUOUS DUTY
FLOW RATE	POWER
± 0,5%	UP TO 80
ACCURACY	USERS



ELECTRONIC METER INTEGRATED



SELF SERVICE MC

PACKAGING

CODE	WEIGHT		PACKAGING			N. BOXES / EUROPALLET	
	KG	LBS	MM	INCH	PCS/BOX	✕	

COLUMN VERSION

FO073801D	67	148	1478X488X400	-	1	6	4
FO074101D	75	165	1478X488X400	-	1	6	4
FO073806A	75	148	1478X488X400	-	1	6	4

TANK VERSION

FO0738B0D	57	126	1080X488X400	-	1	6	4
FO0741B0D	65	143	1080X488X400	-	1	6	4



FILTRATION



TANK MONITORING



HOSE REEL



ACCESSORIES



MERCHANDISE

INDEX



AIR



ANTIFREEZE



AdBlue®



BIODIESEL



DIESEL



FOOD



GASOLINE



GREASE



KEROSENE



OIL



WATER



WINDSCREEN

CHART

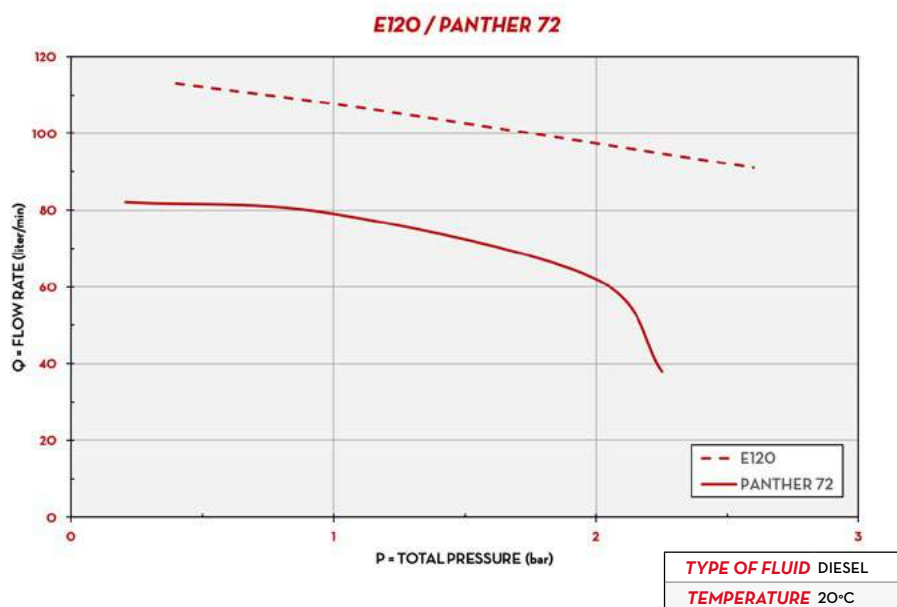

DIMENSIONS

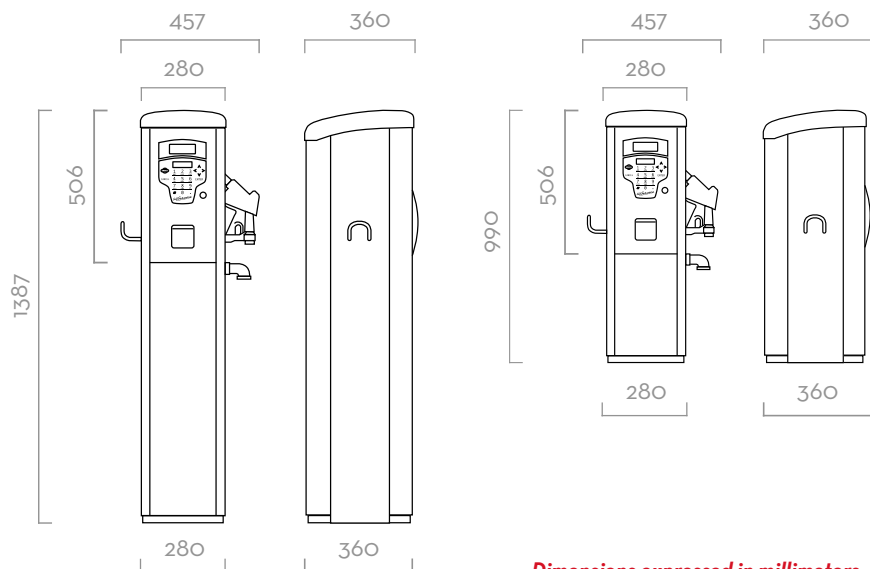

IN THE BOX

- SELF SERVICE MC DISPENSER
- DELIVERY HOSE
- AUTOMATIC NOZZLE
- INSTRUCTION MANUAL

DETAILS



TANK VERSION AVAILABLE



WATER CAPTOR FILTER (pag. 170)



DRIVER KEY (not included)



SSM 2018 SOFTWARE (pag. 42)

MATERIALS

- **PUMPS:**
PANTHER 72 / E120 PAG. 102/106
- **METER:**
K600/3 PAG. 134
- **NOZZLE:**
AUTOMATIC NOZZLE PAG. 158
- **FILTER:**
WATER CAPTOR PAG. 170

TECHNICAL DATA

CODE	DESCRIPTION	FLUIDS TYPE	FLOW RATE		VOLTAGE			PUMP TYPE	METER TYPE	NOZZLE TYPE	FILTER		INLET BSP	HOSE LENGTH METERS	PC CONNECTION
			L/MIN	GPM	AC V./HZ DC VOLT	POWER WATT	AMP. MAX.				H2O FILTER	FILTERING CAPACITY			

COLUMN VERSIONS

FO073801D	SELF SERVICE 70 MC F	D	70	18	230/50	900	4,2	PANTH 72	K600	A80	YES	30µ	1" 1/2	4	YES
FO074101D	SELF SERVICE 100 MC F	D	90	24	230/50	1150	5,7	E 120	K600	A120	YES	30µ	1" 1/2	4	YES
FO073806A	SELF SERVICE 70 MC F PRINTER	D	70	18	230/50	900	4,2	PANTH 72	K600	A80	YES	30µ	1" 1/2	4	YES

TANK VERSIONS

FO0738B0D	SELF SERVICE 70 MC TANK	D	70	18	230/50	900	3,3	PANTH 72	K600	A80	NO	-	1" 1/2	4	YES
FO0741B0D	SELF SERVICE 100 MC TANK	D	90	24	230/50	1150	5,7	E 120	K600	A120	NO	-	1" 1/2	4	YES

WITH 7M HOSE. UPON REQUEST IT IS AVAILABLE WITH DIFFERENT VOLTAGES AND 60 HZ FREQUENCY

SELF SERVICE MC



SELF SERVICE FM

FEATURES

- TICKET PRINTER
- MULTI-USER MANAGEMENT
- WATER CAPTOR FILTER
- TANK LEVEL INDICATOR
- STURDY STRUCTURE
- COMPATIBLE WITH SSM 2018 SOFTWARE
- IP55

The PIUSI SELF SERVICE FM is a dispenser for diesel with integrated OCIO tank level indicator. It is equipped with a high-capacity vane pump, built-in bypass, automatic nozzle, water captor filter and electronic panel able to manage up to 120 users and 255 transactions. It is compatible with SSM2018 software.

PERFORMANCE

UP TO 90 L/MIN	AC CONTINUOUS DUTY
FLOW RATE	POWER
± 0,5%	UP TO 120
ACCURACY	USERS



INTEGRATED TICKET PRINTER



SELF SERVICE FM

PACKAGING

CODE	WEIGHT		PACKAGING			N. BOXES / EURO PALLET	
	KG	LBS	MM	INCH	PCS/BOX	✕	
FO073900C	67	148	1478X488X400	-	1	6	4
FO074200C	75	165	1478X488X400	-	1	6	4
FO0739B0C	57	126	1080X488X400	-	1	6	4
FO0742B0C	65	143	1080X488X400	-	1	6	4



FILTRATION



TANK MONITORING



HOSE REEL



ACCESSORIES



MERCHANDISE

INDEX



AIR



ANTIFREEZE



AdBlue®



BIODIESEL



DIESEL



FOOD



GASOLINE



GREASE



KEROSENE



OIL



WATER



WINDSCREEN

CHART

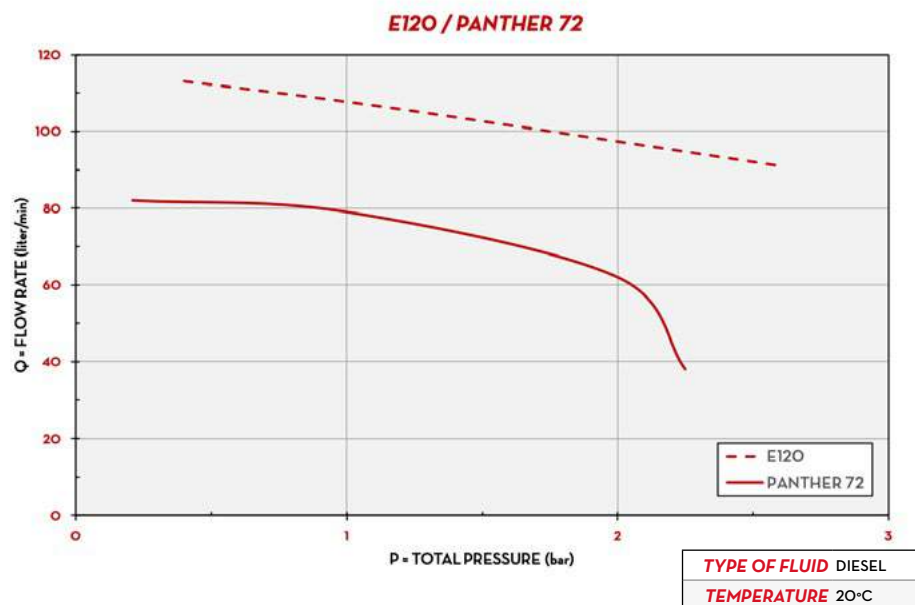

DIMENSIONS

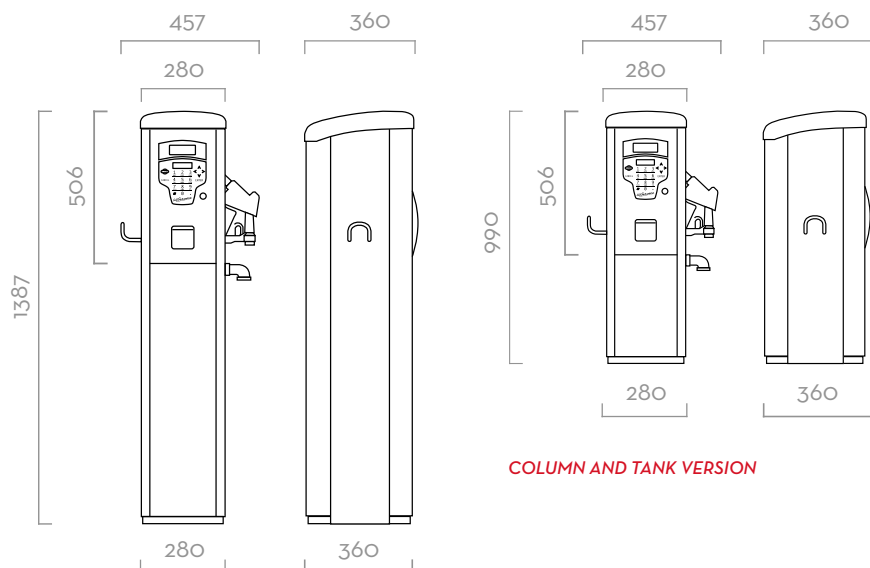

COLUMN AND TANK VERSION

Dimensions expressed in millimeters

IN THE BOX

- SELF SERVICE FM DISPENSER
- DELIVERY HOSE
- AUTOMATIC NOZZLE
- INSTRUCTION MANUAL

DETAILS



TANK VERSION AVAILABLE



WATER CAPTOR FILTER (pag. 170)



OCIO INTEGRATED



SSM 2018 SOFTWARE (pag. 42)

MATERIALS

- **PUMPS:**
E80 / E120 PAG. 106
- **METER:**
K600/3 PAG. 134
- **NOZZLE:**
AUTOMATIC NOZZLE PAG. 158
- **FILTER:**
WATER CAPTOR PAG. 170

TECHNICAL DATA

CODE	DESCRIPTION	FLUIDS TYPE	FLOW RATE		VOLTAGE			PUMP TYPE	METER TYPE	NOZZLE TYPE	FILTER		INLET BSP	HOSE LENGTH METERS	PC CONNECTION
			L/MIN	GPM	AC V/HZ DC VOLT	POWER WATT	AMP. MAX.				H2O FILTER	FILTERING CAPACITY			
FO073900C	SELF SERVICE 70 FM	D	70	18	230/50	550	3,3	PANTH 72	K600	A80	YES	30µ	1" 1/2	4	YES
FO074200C	SELF SERVICE 100 FM	D	90	24	230/50	1150	5,7	E 120	K600	A120	YES	30µ	1" 1/2	4	YES
FO073980C	SELF SERVICE 70 FM TANK	D	70	18	230/50	550	3,3	PANTH 72	K600	A80	NO	-	1" 1/2	4	YES
FO074280C	SELF SERVICE 100 FM TANK	D	90	24	230/50	1150	5,7	E 120	K600	A120	NO	-	1" 1/2	4	YES

UPON REQUEST IT IS AVAILABLE WITH DIFFERENT VOLTAGES AND 60 HZ FREQUENCY

SELF SERVICE FM



FUEL MANAGEMENT SYSTEMS



DISPENSERS



KITS



PUMPS



METERS



NOZZLES

MCBOX

FEATURES

- ACCESS CONTROL
- SUITABLE FOR ANY PUMP
- PULSE METER INPUT
- EASY TO INSTALL
- MULTI USERS
- COMPATIBLE WITH SSM2018 SOFTWARE

The PIUSI MCBOX is a practical electronic multi-user control panel that allows to manage and control an existing pump, pulse meter and nozzle. Integrated with the SELF SERVICE MANAGEMENT 2018, it grants the possibility to download all the transactions.

PERFORMANCE

120

USERS

AC/DC

VOLTAGE

POWER

255

TRANSACTION MEMORY



MCBOX



PACKAGING

CODE	WEIGHT		PACKAGING		
	KG	LBS	MM	INCH	PCS/BOX
F1398000C	5	11	300X300X180	11,8X11,8X7	1
F1398005B	5	11	300X300X180	11,8X11,8X7	1
F1398001B	6	13	300X300X180	11,8X11,8X7	1
F1398002B	6	13	300X300X180	11,8X11,8X7	1



FILTRATION



TANK MONITORING



HOSE REEL



ACCESSORIES



MERCHANDISE

INDEX



AIR



ANTIFREEZE



AdBlue®



BIODIESEL



DIESEL



FOOD



GASOLINE



GREASE



KEROSENE



OIL



WATER



WINDSCREEN

CONNECTION SCHEME



PUMP CONTROL



PULSE METER INPUT



TANK LEVEL INDICATOR



NOZZLE SWITCH WITH A60



IN THE BOX

- MCBOX UNIT
- INSTRUCTION MANUAL

DETAILS



EASY ACCESS TO CONNECTION



SSM 2018 SOFTWARE (pag. 42)



SHUTTER

DIMENSIONS

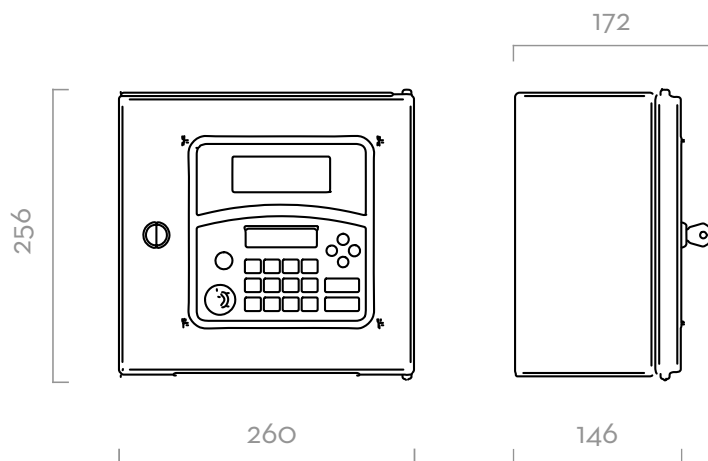

Dimensions expressed in millimeters

TECHNICAL DATA

CODE	DESCRIPTION	FLUIDS TYPE	USERS	VOLTAGE			SSM 2018 SOFTWARE
				AC V./HZ	POWER WATT	AMP. MAX. (load motor)	
F139800OC	MCBOX_230V50/60HZ_80U_IBP	A Ad B D F G G K O W W	80	230/50	35	6,5	OPTIONAL
F1398005B	MCBOX_230V50/60HZ_120U_IBP	A Ad B D F G G K O W W	120	230/50	35	6,5	OPTIONAL
F1398001B	MCBOX_12V_120U_IBP	A Ad B D F G G K O W W	120	12	10	50	OPTIONAL
F1398002B	MCBOX_24V_120U_IBP	A Ad B D F G G K O W W	120	24	10	25	OPTIONAL



FUEL MANAGEMENT SYSTEMS

ACCESSORIES

B.SMART

CUBE B.SMART	CODE	DESCRIPTION
	FO0770D00	DRIVER ACCESS (X05)
	FO0770D10	DRIVER ACCESS (X15)
	FO0770D20	DRIVER ACCESS (X50)
	F1590400A	USER KEY (YELLOW KEY: 10PCS)
	F1270800C	PEDESTAL
	F1273700A	KIT WALL SUPPORT



SELF SERVICE MC B.SMART	CODE	DESCRIPTION
	FO0770D00	DRIVER ACCESS (X05)
	FO0770D10	DRIVER ACCESS (X15)
	FO0770D20	DRIVER ACCESS (X50)
	F1590400A	USER KEY (YELLOW KEY: 10PCS)



MCBOX B.SMART	CODE	DESCRIPTION
	FO0770D00	DRIVER ACCESS (X05)
	FO0770D10	DRIVER ACCESS (X15)
	FO0770D20	DRIVER ACCESS (X50)
	F1590400A	USER KEY (YELLOW KEY: 10PCS)
	F1270800C	PEDESTAL
	F1273700A	KIT WALL SUPPORT
F17121000	LEVEL PROBE FOR ACCESS 85	



SSM2.0

CUBE MC 2.0	CODE	DESCRIPTION
	F0893000A	KIT QUICK COUPLING 2IN X 1IN
	F1270800C	KIT PEDESTAL CUBE BLACK
	F1273700A	WALL KIT CUBE
	F1273800A	KIT PADLOCK CUBE MC
	F1590400A	KIT DRIVER KEY YELLOW (10PCS)
	F17163000	2" BSP DRUM CONNECTOR WITH VALVE
	F17299000	KIT VEHICLE KEY BLUE (10PCS)



SELF SERVICE MC 2.0	CODE	DESCRIPTION
	F1590400A	KIT DRIVER KEY YELLOW (10PCS)
	F17299000	KIT VEHICLE KEY BLUE (10PCS)



SELF SERVICE FM 2.0	CODE	DESCRIPTION
	F1590400A	KIT DRIVER KEY YELLOW (10PCS)
	F17299000	KIT VEHICLE KEY BLUE (10PCS)



SSM2.0

MCBOX 2.0	CODE	DESCRIPTION
	F1270800C	KIT PEDESTAL CUBE BLACK
	F1590400A	KIT DRIVER KEY YELLOW (10PCS)
	F17299000	KIT VEHICLE KEY BLUE (10PCS)
	F17121000	LEVEL PROBE FOR ACCESS 85



SSM2018

CUBE MC	CODE	DESCRIPTION
	F0893000A	KIT QUICK COUPLING 2IN X 1IN
	F1249600A	MANAGER KEY 2018
	F1270800C	KIT PEDESTAL CUBE BLACK
	F1273700A	WALL KIT CUBE
	F1273800A	KIT PADLOCK CUBE MC
	F1590400A	KIT DRIVER KEY YELLOW (10PCS)
	F17163000	2" BSP DRUM CONNECTOR WITH VALVE

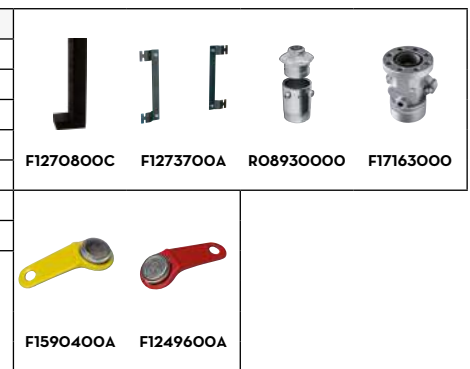

SELF SERVICE MC	CODE	DESCRIPTION
	F1249600A	MANAGER KEY 2018
	F1590400A	KIT DRIVER KEY YELLOW (10PCS)



SELF SERVICE FM	CODE	DESCRIPTION
	F1249600A	MANAGER KEY 2018
	F1590400A	KIT DRIVER KEY YELLOW (10PCS)



MCBOX	CODE	DESCRIPTION
	F1249600A	MANAGER KEY 2018
	F1270800C	KIT PEDESTAL CUBE BLACK
	F1590400A	KIT DRIVER KEY YELLOW (10PCS)
	F1623900B	NOZZLE HOLDER SS+CABLED SWITCH FM/MC
	F17121000	LEVEL PROBE FOR ACCESS 85

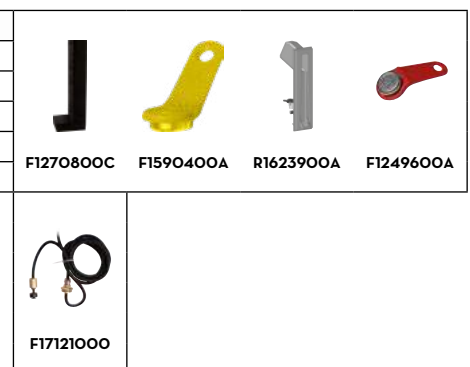



DISPENSERS

A large, solid red triangle is positioned in the bottom right corner of the page, pointing towards the top right.



FUEL MANAGEMENT SYSTEMS



DISPENSERS



KITS



PUMPS



METERS



NOZZLES

CUBE

FEATURES

- STURDY STRUCTURE
- MECHANICAL METER
- INDUCTION THERMAL-PROTECTED MOTOR
- OVERLOAD PROTECTION
- BUILT-IN MESH FILTER
- IP 55

The PIUSI CUBE is a range of mechanical fuel transfer dispenser for non-commercial use, composed of a self-priming vane pump fitted with integrated bypass valve, automatic nozzle with swivel connection and integrated nozzle holder with start/stop pump lever. Its versatility allows different applications: on walls, on tanks, on cisterns, on drums or stand-alone (with the optional pedestal).

PERFORMANCE

UP TO
90 L/MIN

FLOW RATE

AC/DC

VOLTAGE
POWER

±1%

ACCURACY



CUBE 56 WITH FILTER



CUBE 56 WITH PEDESTAL (OPTIONAL)

PACKAGING

CODE	WEIGHT		PACKAGING			N. BOXES / EUROPALLET	
	KG	LBS	MM	INCH	PCS/BOX		
FO0575400	22	46	400X400X460	-	1	12	24
OO057516A	21	46	400X400X460	-	1	12	24
OO057500C	21	46	400X400X460	-	1	12	24
FO057600C	21	46	400X400X460	-	1	12	24
FO057700C	21	46	400X400X460	-	1	12	24
FO0591200	22	48	400X400X460	-	1	12	24
FO059100A	21	46	400X400X460	-	1	12	24
FO059111A	21	46	400X400X460	-	1	12	24
FO0592000	22	46	400X400X460	-	1	12	24



FILTRATION



TANK MONITORING



HOSE REEL



ACCESSORIES



MERCHANDISE

INDEX



AIR



ANTIFREEZE



AdBlue®



BIODIESEL



DIESEL



FOOD



GASOLINE



GREASE



KEROSENE



OIL



WATER



WINDSCREEN

CHART

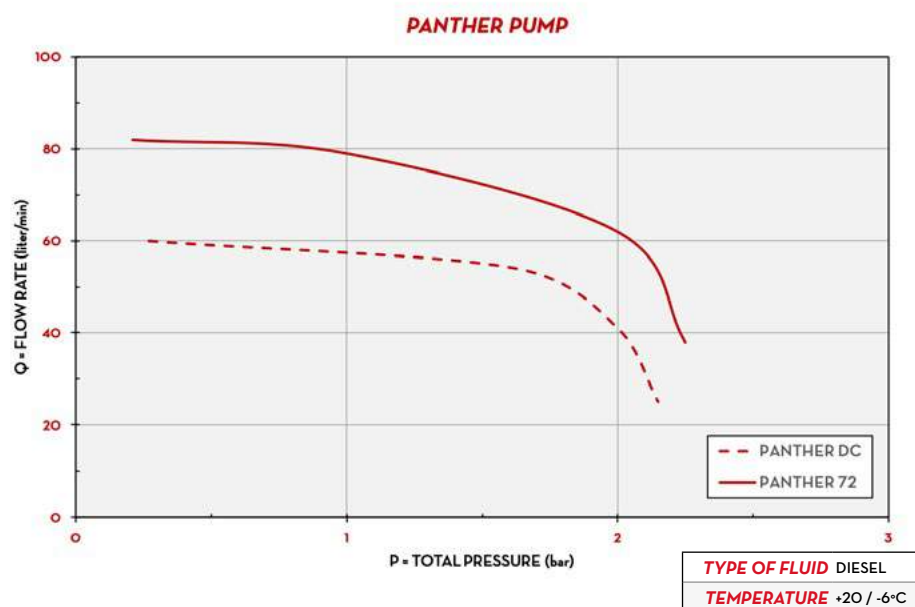

IN THE BOX

- CUBE DISPENSER
- AUTOMATIC NOZZLE
- DELIVERY HOSE
- INSTRUCTION MANUAL

DETAILS



NUTATING DISK METER



K33/K44 (pag. 146)

DIMENSIONS

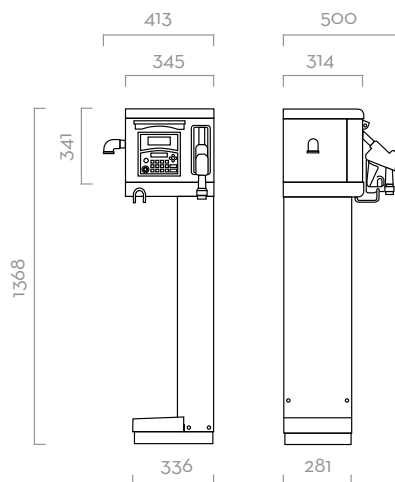

Dimensions expressed in millimeters

COMPONENTS

- **PUMPS:**
PANTHER AC PAG. 102
PANTHER DC PAG. 114
- **METER:**
K33 / K44 PAG. 146
- **NOZZLE:**
AUTOMATIC NOZZLE PAG. 158

TECHNICAL DATA

CODE	DESCRIPTION	FLUIDS TYPE	FLOW RATE		VOLTAGE			PUMP	METER	NOZZLE	FILTER		INLET	HOSE	
			L/MIN	GPM	AC V./HZ	DC VOLT	POWER WATT				AMP. MAX.	H2O FILTER		FILTERING CAPACITY	BSP
FO0575400	CUBE 56/33 + FILTER	D	56	15	230/50	350	3	PANTH 56	K33	A60	YES	30 µ	1"	6M	3/4"
OO057516A	CUBE 56/44 PULSER	D	56	15	230/50	350	3	PANTH 56	K44	A60	NO	-	1"	4M	3/4"
OO057500C	CUBE 56/33	D	56	15	230/50	350	3	PANTH 56	K33	A60	NO	-	1"	4M	3/4"
FO057600C	CUBE 56 DC 12V	D	56	15	12	300	35	PANTH DC	K33	A60	NO	-	1"	4M	1"
FO057700C	CUBE 70 DC 24V	D	70	18	24	420	25	PANTH DC	K33	A60	NO	-	1"	4M	3/4"
FO0591200	CUBE 70/33 + FILTER	D	70	18	230/50	500	4,2	PANTH 72	K33	A60	YES	30 µ	1"	6M	1"
FO059100A	CUBE 70/33	D	70	18	230/50	500	4,2	PANTH 72	K33	A60	NO	-	1"	4M	1"
FO059111A	CUBE 70/44 PULSER	D	70	18	230/50	500	4,2	PANTH 72	K44	A60	NO	-	1"	4M	1"
FO0592000	CUBE 90/44	D	90	23,8	230/50	700	4,9	PANTH 90	K44	A120	NO	-	1"	4M	1"

UPON REQUEST IT IS AVAILABLE WITH DIFFERENT VOLTAGES AND 50/60 HZ FREQUENCY

CUBE



FUEL MANAGEMENT
SYSTEMS



DISPENSERS



KITS



PUMPS



METERS



NOZZLES

SELF SERVICE K44

FEATURES

- ALL-IN-ONE EQUIPMENT
- WATER CAPTOR FILTER
- COMPACT DESIGN
- IP55

The PIUSI SELF SERVICE K44 is a fuel dispenser unit equipped with a high capacity vane pump, built-in bypass valve and mechanical K44 meter. Particularly suitable for all the needs of high-flow rate diesel dispensing, it guarantees that the dispensed product is free of water and impurities thanks to the integrated filter (column version). Available both as column or tank version, it features a front door for easy maintenance.

PERFORMANCE

UP TO

90 L/MIN

FLOW RATE

AC

CONTINUOUS DUTY

POWER

±1%

ACCURACY



MECHANICAL METER INTEGRATED



SELF SERVICE K44

PACKAGING

CODE	WEIGHT		PACKAGING			N. BOXES / EUROPALET	
	KG	LBS	MM	INCH	PCS/BOX	✈	🚛

COLUMN VERSIONS

FO073701B	67	148	1478X488X400	-	1	6	4
FO074001B	75	165	1478X488X400	-	1	6	4
FO074002A	75	165	1478X488X400	-	1	6	4

TANK VERSIONS

FO0737B0B	57	126	1080X488X400	-	1	6	4
FO0740B0B	65	143	1080X488X400	-	1	6	4
FO0737B2B	57	126	1080X488X400	-	1	6	4



FILTRATION



TANK MONITORING



HOSE REEL



ACCESSORIES



MERCHANDISE

INDEX



AIR



ANTIFREEZE



AdBlue®



BIODIESEL



DIESEL



FOOD



GASOLINE



GREASE



KEROSENE



OIL



WATER



WINDSCREEN

CHART

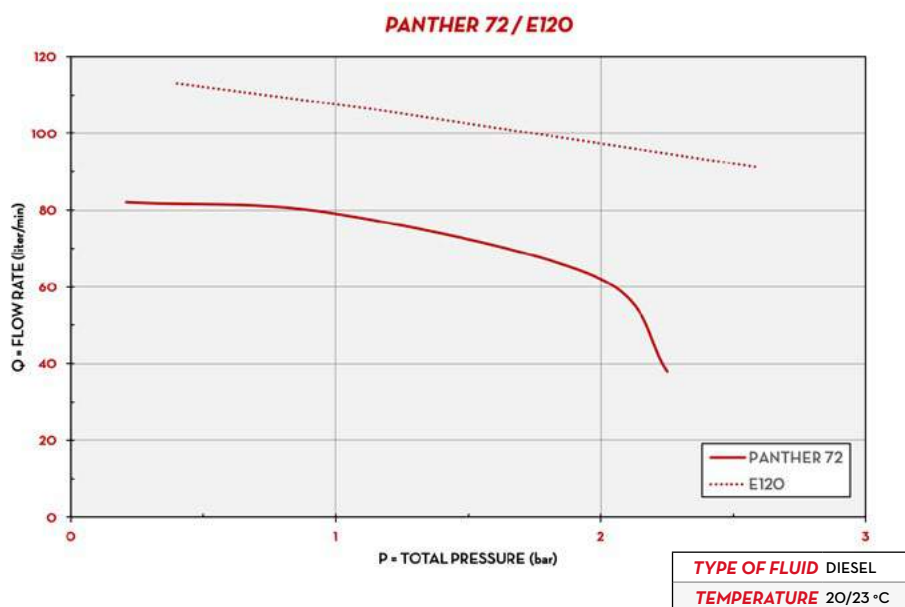

IN THE BOX

- SELF SERVICE K44 DISPENSER
- DELIVERY HOSE
- AUTOMATIC NOZZLE
- INSTRUCTION MANUAL

DETAILS



DIMENSIONS

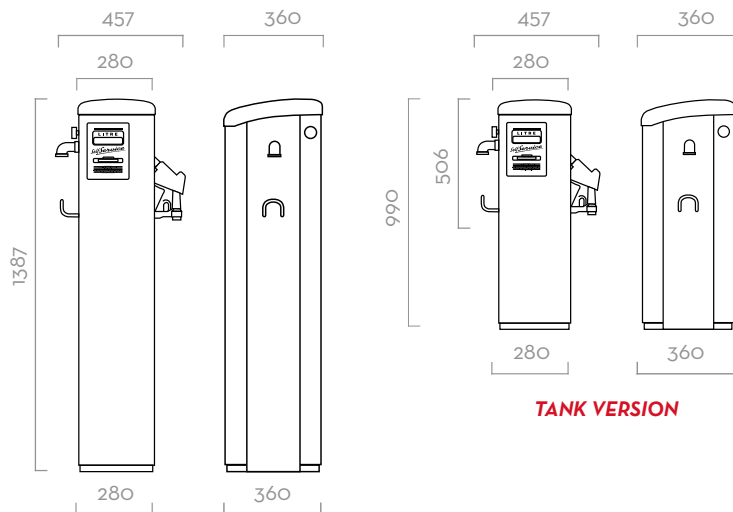

COLUMN VERSION

TANK VERSION

Dimensions expressed in millimeters

COMPONENTS

- **PUMPS:**
PANTHER AC / E120 PAG. 102/106
K44 PAG. 146
- **NOZZLE:**
AUTOMATIC NOZZLE PAG. 158
- **FILTER:**
WATER CAPTOR PAG. 170

TECHNICAL DATA

CODE	DESCRIPTION	FLUIDS TYPE	FLOW RATE		VOLTAGE			PUMP	METER	NOZZLE	FILTER		INLET	HOSE LENGTH	PC
			L/MIN	GPM	AC V/Hz	DC VOLT	POWER WATT				AMP. MAX.	H2O FILTER			
COLUMN VERSIONS															
FO073701B	SELF SERVICE 70 K44	D	70	18	230/50	550	3,3	PANTH 72	K44	A80	YES	30µ	1" 1/2	4	NO
FO074001B	SELF SERVICE 100 K44	D	90	24	230/50	1150	5,7	E 120	K44	A120	YES	30µ	1" 1/2	4	NO
FO074002A	SELF SERVICE 100 K44 PULSER	D	90	24	230/50	1150	5,7	E 120	K44 P	A120	YES	30µ	1" 1/2	4	NO
TANK VERSIONS															
FO0737B0B	SELF SERVICE 70 K44 TANK	D	70	18	230/50	550	3,3	PANTH 72	K44	A80	NO	-	1" 1/2	4	NO
FO0740B0B	SELF SERVICE 100 K44 TANK	D	90	24	230/50	1150	5,7	E 120	K44	A120	NO	-	1" 1/2	4	NO
FO0737B2B	SELF SERVICE 70 K44 TANK PULSER	D	70	18	230/50	550	3,3	PANTH 72	K44 P	A80	NO	-	1" 1/2	4	NO





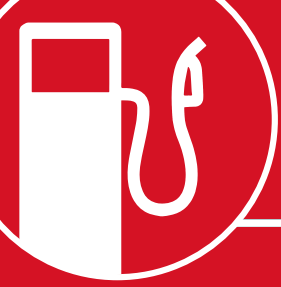

UPON REQUEST IT IS AVAILABLE WITH DIFFERENT VOLTAGES AND 60 HZ FREQUENCY

SELF SERVICE K44



DISPENSERS ACCESSORIES

MECHANICAL DISPENSER

CUBE	CODE	DESCRIPTION						
	FO893000A	KIT QUICK COUPLING 2IN X 1IN						
	F1270800C	KIT PEDESTAL CUBE BLACK						F1270800C
	F1273700A	WALL KIT CUBE						F1273700A
	F1273800A	KIT PADLOCK CUBE MC						R08930000
	F17163000	2" BSP DRUM CONNECTOR WITH VALVE						R12738000
				F17163000				





KITS





FUEL MANAGEMENT SYSTEMS



DISPENSERS



KITS



PUMPS



METERS



NOZZLES

EX50 DRUM

FEATURES

- STURDY STRUCTURE
- FLANGED COMPONENTS
- ANTI-NOISE FILTER
- THERMAL PROTECTION
- BUILT-IN BYPASS VALVE
- SUCTION PIPE WITH INTEGRATED FILTER
- UL LISTED VERSION AVAILABLE

The PIUSI EX50 DRUM is a complete pump transfer kit expressly engineered for ATEX/IECEx areas. This system is composed of a high-efficiency pump, manual or automatic nozzle and a telescopic suction hose. Thanks to the flanged components, this transfer set allows users to replace any component without using sealants thus creating maximum versatility and adaptability to any kind of condition. K33 mechanical meter available on request.



PIUSI EX50 DRUM WITH METER AND FILTER



PERFORMANCE

UP TO
50 L/MIN

FLOW RATE

1100 MM

SUCTION PIPE

±1%

ACCURACY

200β/30μ

FILTERING CAPACITY



EX50 DRUM WITH AUTOMATIC NOZZLE



EX50 DRUM WITH AUTOMATIC NOZZLE

OUR PUMPS COMPLIES WITH THE FOLLOWING MARKING ATEX/IECEx

II	2	G	Ex	d	IIA	T4	Gb
GROUP	CATEGORY	TYPE OF EXPLOSIVE ATMOSPHERE	PERMANENT PREFIX	PROTECTION METHOD	GAS GLASS	TEMPERATURE CLASS	EQUIPMENT PROTECTION LEVEL

PACKAGING

CODE	WEIGHT		PACKAGING		
	KG	LBS	MM	INCH	PCS/BOX
WITHOUT METER					
FO0372000	10	22	600X400X290	23,6X13,7X11,4	1
FO0372010	10	22	600X400X290	23,6X13,7X11,4	1
FO0372020	7,9	17,4	345X175X225	-	1
FO0372030	10	22	600X400X290	23,6X13,7X11,4	1
FO0372040	10	22	600X400X290	23,6X13,7X11,4	1
FO037400A	10	22	600X400X290	23,6X13,7X11,4	1
FO037401A	10	22	600X400X290	23,6X13,7X11,4	1
FO037402A	7,9	17,4	345X175X225	-	1
WITH METER					
FO037500A	12	22	600X400X290	23,6X13,7X11,4	1
FO037501A	12	22	600X400X290	23,6X13,7X11,4	1
FO037502A	12	22	600X400X290	23,6X13,7X11,4	1
FO037503A	12	22	600X400X290	23,6X13,7X11,4	1
FO037600B	12	22	600X400X290	23,6X13,7X11,4	1
FO037601B	12	22	600X400X290	23,6X13,7X11,4	1



FILTRATION



TANK MONITORING



HOSE REEL



ACCESSORIES



MERCHANDISE

INDEX



AIR



ANTIFREEZE



AdBlue®



BIODIESEL



DIESEL



FOOD



GASOLINE



GREASE



KEROSENE



OIL



WATER



WINDSCREEN

CHART



TYPE OF FLUID DIESEL
TEMPERATURE 20/23°C

DIMENSIONS

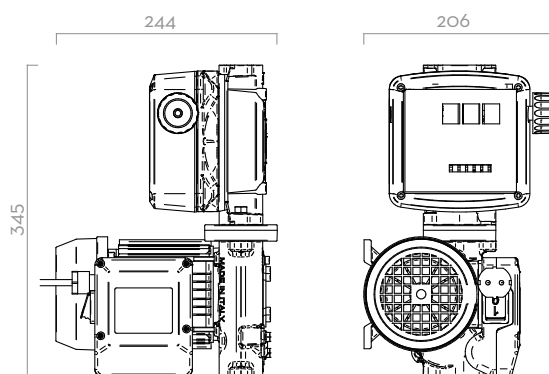

Dimensions expressed in millimeters

IN THE BOX

- EX50 PUMP
- TELESCOPIC SUCTION PIPE
- DELIVERY HOSE
- WATER CAPTOR FILTER
- NOZZLE
- 2" CONNECTOR
- K33 MECHANICAL METER (ON REQUEST)
- INSTRUCTION MANUAL

DETAILS



2" CONNECTOR



INTEGRATED FILTER



BENDING PROTECTION

COMPONENTS

- **PUMP:**
EX50 PAG. 94
- **METER:**
K33 ATEX PAG. 128
- **NOZZLE:**
A60 ATEX PAG. 156
SELF3000 PAG. 162
- **FILTER:**
WATER CAPTOR PAG. 170

TECHNICAL DATA

CODE	DESCRIPTION	FLUIDS TYPE	FLOW RATE		VOLTAGE			METER	NOZZLE	FILTER	INLET	HOSE	
			L/MIN	GPM	AC V/ HZ	DC VOLT	POWER WATT					AMP. MAX.	BSP
WITHOUT METER													
FO0372000	DRUM EX50 12V DC ATEX + MAN. NOZZLE	D G K	50	13	12	250	21	-	SELF3000	YES	1"	4	3/4"
FO0372010	DRUM EX50 12V DC ATEX + AUT. NOZZLE	D G K	50	13	12	250	21	-	A60	YES	1"	4	3/4"
FO0372020	KIT DRUM EX50 12V DC ATEX	D G K	50	13	12	250	21	-	NO	NO	1"	-	-
FO0372030	DRUM EX50 12V DC ATEX + MAN. NOZZLE + CABLE	D G K	50	13	12	250	21	-	SELF3000	YES	1"	4	3/4"
FO0372040	DRUM EX50 12V DC ATEX + AUT. NOZZLE + CABLE	D G K	50	13	12	250	21	-	A60	YES	1"	4	3/4"
FO037400A	DRUM EX50 230V ATEX + MAN. NOZZLE	D G K	50	13	230/50-60	250	1	-	SELF3000	YES	1"	4	3/4"
FO037401A	DRUM EX50 230V ATEX + AUT. NOZZLE	D G K	50	13	230/50-60	250	1	-	A60	YES	1"	4	3/4"
FO037402A	KIT DRUM EX50 230V ATEX	D G K	50	13	230/50-60	250	1	-	NO	NO	1"	-	-
WITH METER													
FO037500A	DRUM EX50 12V DC K33 ATEX + MAN. NOZZLE	D G K	50	13	12	250	21	K33	SELF3000	YES	1"	4	3/4"
FO037501A	DRUM EX50 12V DC K33 ATEX + AUT. NOZZLE	D G K	50	13	12	250	21	K33	A60	YES	1"	4	3/4"
FO037502A	DRUM EX50 12V DC K33 ATEX + MAN. NOZZLE + CABLE	D G K	50	13	12	250	21	K33	SELF3000	YES	1"	4	3/4"
FO037503A	DRUM EX50 12V DC K33 ATEX + AUT. NOZZLE + CABLE	D G K	50	13	12	250	21	K33	A60	YES	1"	4	3/4"
FO037600B	DRUM EX50 230V K33 ATEX + MAN. NOZZLE	D G K	50	13	230/50-60	250	1	K33	SELF3000	YES	1"	4	3/4"
FO037601B	DRUM EX50 230V K33 ATEX + AUT. NOZZLE	D G K	50	13	230/50-60	250	1	K33	A60	YES	1"	4	3/4"

() UPON REQUEST IT IS AVAILABLE WITH DIFFERENT VOLTAGES AND 60 HZ FREQUENCY. COMPATIBLE FLUIDS: DIESEL, KEROSENE, PETROL, PETROL ALCOHOL MIXED MAX 15%, AVGAS 100/100LL (ONLY PUMP&METER), JET A/A1 (ONLY PUMP&METER), ASPEN 2/4

EX50 DRUM



FUEL MANAGEMENT SYSTEMS



DISPENSERS



KITS



PUMPS



METERS



NOZZLES

EX100 DRUM

FEATURES

- CONTINUOUS DUTY
- THERMAL PROTECTION
- SUCTION UNIT WITH INTEGRATED FILTER
- UL VERSION AVAILABLE
- HIGH FLOW RATE

PIUSI EX100 DRUM is the new transfer kit for flammable fluids that is characterized by a high flow rate and works with a continuous duty cycle. Simple to use, compact, versatile, it adapts to any working conditions: you can use it wherever you need it most. The PIUSI EX100 DRUM is ATEX certified and complies with the directives on the use of materials in potentially explosive atmospheres.



PERFORMANCE

UP TO
100 L/MIN

FLOW RATE

AC
VOLTAGE

POWER



EX100

OUR PUMPS COMPLIES WITH THE FOLLOWING MARKING ATEX/IECEx

II	2	G	Ex	d	IIA	T4	Gb
GROUP	CATEGORY	TYPE OF EXPLOSIVE ATMOSPHERE	PERMANENT PREFIX	PROTECTION METHOD	GAS GLASS	TEMPERATURE CLASS	EQUIPMENT PROTECTION LEVEL

PACKAGING

CODE	WEIGHT		PACKAGING		
	KG	LBS	MM	INCH	PCS/BOX
FO0391010	25	55	240X400X390	10X16X15	1
FO0391020	25	55	240X400X390	10X16X15	1
FO0390030	25	55	240X400X390	10X16X15	1



FILTRATION



TANK MONITORING



HOSE REEL



ACCESSORIES



MERCHANDISE

INDEX



AIR



ANTIFREEZE



AdBlue®



BIODIESEL



DIESEL



FOOD



GASOLINE



GREASE



KEROSENE



OIL



WATER



WINDSCREEN

CHART

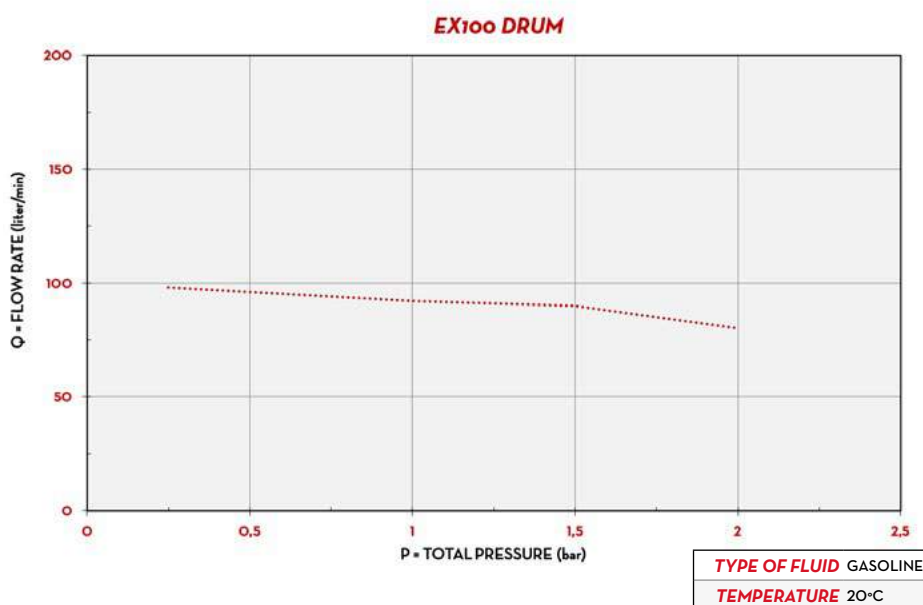

DIMENSIONS

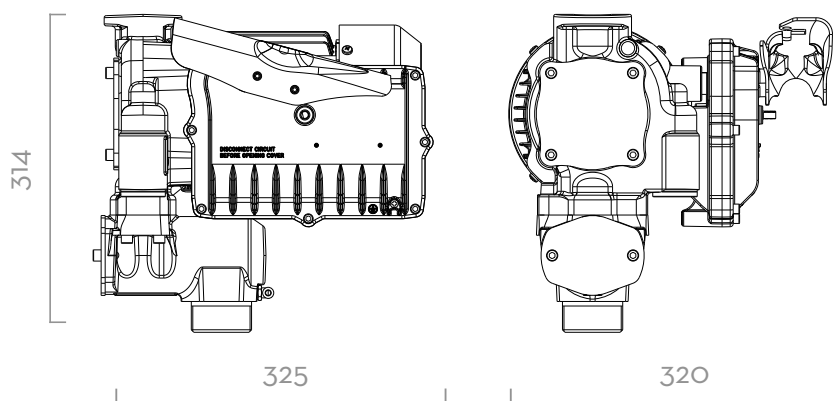

Dimensions expressed in millimeters

IN THE BOX

- EX100 PUMP
- NOZZLE HOLDER
- 2" TANK CONNECTOR
- 90° ELBOW
- FILTER (ON SELECTED VERSION)
- METER (ON SELECTED VERSION)
- AUTOMATIC NOZZLE (ON SELECTED VERSION)
- INSTRUCTION MANUAL

DETAILS



MATERIALS

- BODY: CAST IRON
- ROTOR: SINTERED STEEL
- VANES: TECHNOPOLYMER
- SEAL: VITON
- SHAFT: STEEL

TECHNICAL DATA

CODE	DESCRIPTION	FLUIDS TYPE	FLOW RATE		VOLTAGE			DUTY CICLE	RPM	INLET TANK CONNECTOR	OUTLET
			L/MIN	GPM	AC V/HZ DC VOLT	POWER WATT	AMP. MAX.				
FO0391010	(EX) EX100 DRUM 230V/50	D G K	100	25	230/50	1035	4,5	YES	1450	2"	1"
FO0391020	(EX) EX100 DRUM 230V/60	D G K	100	25	230/60	874	3,8	YES	1750	2"	1"
FO0390030	(EX) EX100 250/50 ATEX	D G K	100	25	250/50	1125	4,5	YES	1450	2"	1"

() UPON REQUEST IT IS AVAILABLE WITH DIFFERENT VOLTAGES AND 60 HZ FREQUENCY. COMPATIBLE FLUIDS: DIESEL, KEROSENE, PETROL, PETROL ALCOHOL MIXED MAX 15%, AVGAS 100/100LL, JET A/A1 - ASPEN 2/4

EX100 DRUM



FUEL MANAGEMENT SYSTEMS



DISPENSERS



KITS



PUMPS



METERS



NOZZLES

EX140 DRUM

FEATURES

- CONTINUOUS DUTY
- THERMAL PROTECTION
- SUCTION UNIT WITH INTEGRATED FILTER
- UL VERSION AVAILABLE
- HIGH FLOW RATE

The entire new EX line is characterized by a high flow rate that works with a continuous duty cycle, and has been designed to be particularly suitable for Heavy Duty, i.e. for those demanding fleets that need to dispense fuels such as Gasoline, diesel or kerosene quickly. The PIUSI EX140 DRUM is ATEX certified and complies with the directives on the use of materials in potentially explosive atmospheres.

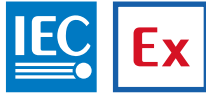

PERFORMANCE

UP TO
140 L/MIN

FLOW RATE

AC
VOLTAGE
POWER



EX140

OUR PUMPS COMPLIES WITH THE FOLLOWING MARKING ATEX/IECEx

II	2	G	Ex	d	IIA	T4	Gb
GROUP	CATEGORY	TYPE OF EXPLOSIVE ATMOSPHERE	PERMANENT PREFIX	PROTECTION METHOD	GAS GLASS	TEMPERATURE CLASS	EQUIPMENT PROTECTION LEVEL

PACKAGING

CODE	WEIGHT		PACKAGING		
	KG	LBS	MM	INCH	PCS/BOX
FO0396010	25	55	240X400X390	10X16X15	1
FO0396020	25	55	240X400X390	10X16X15	1
FO0396030	25	55	240X400X390	10X16X15	1



FILTRATION



TANK MONITORING



HOSE REEL



ACCESSORIES



MERCHANDISE

INDEX



AIR



ANTIFREEZE



AdBlue®



BIODIESEL



DIESEL



FOOD



GASOLINE



GREASE



KEROSENE



OIL



WATER



WINDSCREEN

CHART

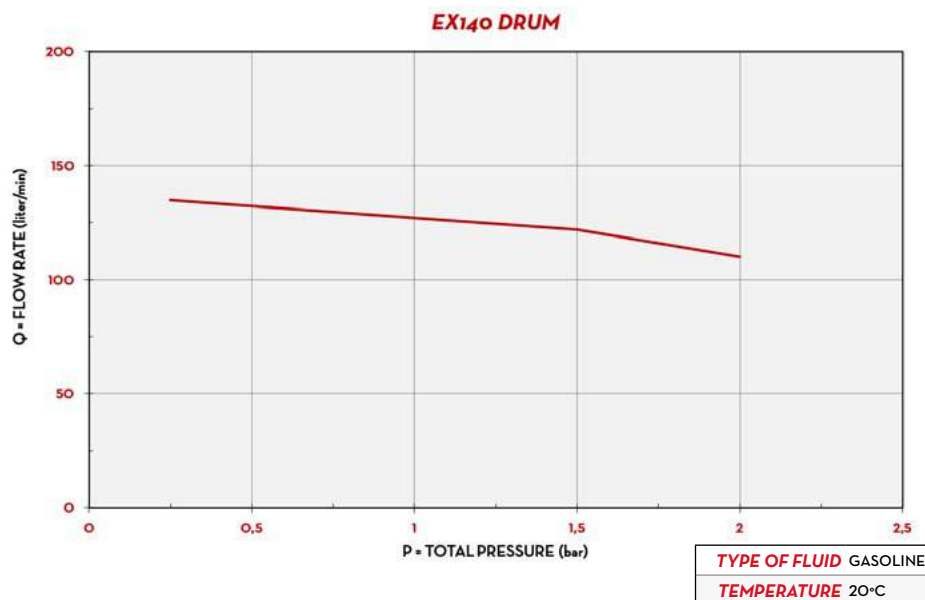

DIMENSIONS

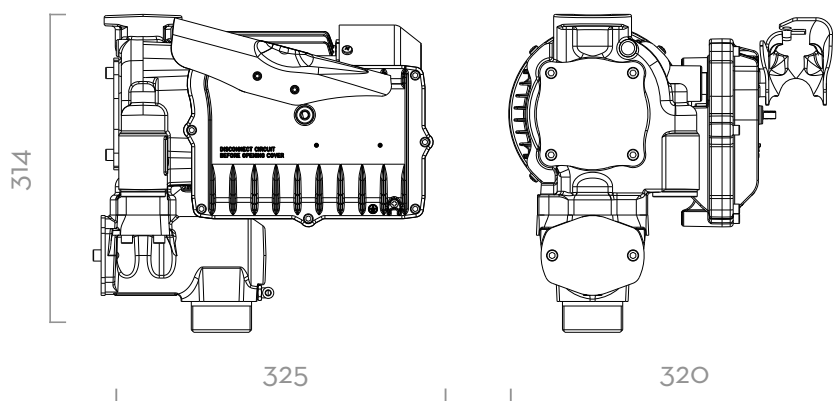

Dimensions expressed in millimeters

IN THE BOX

- EX140 PUMP
- NOZZLE HOLDER
- 2" CONNECTOR
- 90° ELBOW
- FILTER (ON SELECTED VERSION)
- METER (ON SELECTED VERSION)
- AUTOMATIC NOZZLE (ON SELECTED VERSION)
- INSTRUCTION MANUAL

DETAILS



MATERIALS

- BODY: CAST IRON
- ROTOR: SINTERED STEEL
- VANES: TECHNOPOLYMER
- SEAL: VITON
- SHAFT: STEEL

TECHNICAL DATA

CODE	DESCRIPTION	FLUIDS TYPE	FLOW RATE		VOLTAGE			DUTY CICLE	RPM	INLET TANK CONNECTOR	OUTLET
			L/MIN	GPM	AC V/HZ DC VOLT	POWER WATT	AMP. MAX.				
FO0396010	(EX) EX140 DRUM 230V/50	D G K	140	37	230/50	1150	5	YES	1450	2"	1"
FO0396020	(EX) EX140 DRUM 250V/50	D G K	140	37	250/50	1125	4,5	YES	1450	2"	1"
FO0396030	(EX) EX140 DRUM 230V/60	D G K	140	37	230/60	920	4	YES	1750	2"	1"

() UPON REQUEST IT IS AVAILABLE WITH DIFFERENT VOLTAGES AND 60 HZ FREQUENCY. COMPATIBLE FLUIDS: DIESEL, KEROSENE, PETROL, PETROL ALCOHOL MIXED MAX 15%, AVGAS 100/100LL, JET A/A1 - ASPEN 2/4

EX140 DRUM



FUEL MANAGEMENT SYSTEMS



DISPENSERS



KITS



PUMPS



METERS



NOZZLES

EX50 ST

FEATURES

- STURDY STRUCTURE
- COMPACT, VERSATILE
- EASY TO INSTALL
- ANTI-NOISE FILTER
- OVERLOAD PROTECTION

The PIUSI EX50 ST is a sturdy and compact transfer station equipped with an ACEX/IECEX certified pump suitable for the transfer of all flammable liquids. These transfer stations are the final solution for all applications in which mobile or underground tanks need to be equipped with a dispenser unit. Thanks to the flanged components, this transfer set allows users to replace any component without using sealants.



PERFORMANCE

UP TO
50 L/MIN

FLOW RATE

AC
VOLTAGE
POWER

±1%

ACCURACY



PIUSI ST EX50 WITH METER AND NOZZLE
FO0377000



PIUSI ST EX50 WITH METER AND NOZZLE
FO0377010



OUR PUMPS COMPLY WITH THE FOLLOWING MARKING ATEX/IECEX

II	2	G	Ex	d	IIA	T4	Gb
GROUP	CATEGORY	TYPE OF EXPLOSIVE ATMOSPHERE	PERMANENT PREFIX	PROTECTION METHOD	GAS GLASS	TEMPERATURE CLASS	EQUIPMENT PROTECTION LEVEL

PACKAGING

CODE	WEIGHT		PACKAGING		
	KG	LBS	MM	INCH	PCS/BOX

WITH METER

FO0377000	12	24,5	600X400X290	23,6X13,7X11,4	1
FO0377010	12	24,5	600X400X290	23,6X13,7X11,4	1



FILTRATION



TANK MONITORING



HOSE REEL



ACCESSORIES



MERCHANDISE

INDEX



AIR



ANTIFREEZE



AdBlue®



BIODIESEL



DIESEL



FOOD



GASOLINE



GREASE



KEROSENE



OIL



WATER



WINDSCREEN

CHART

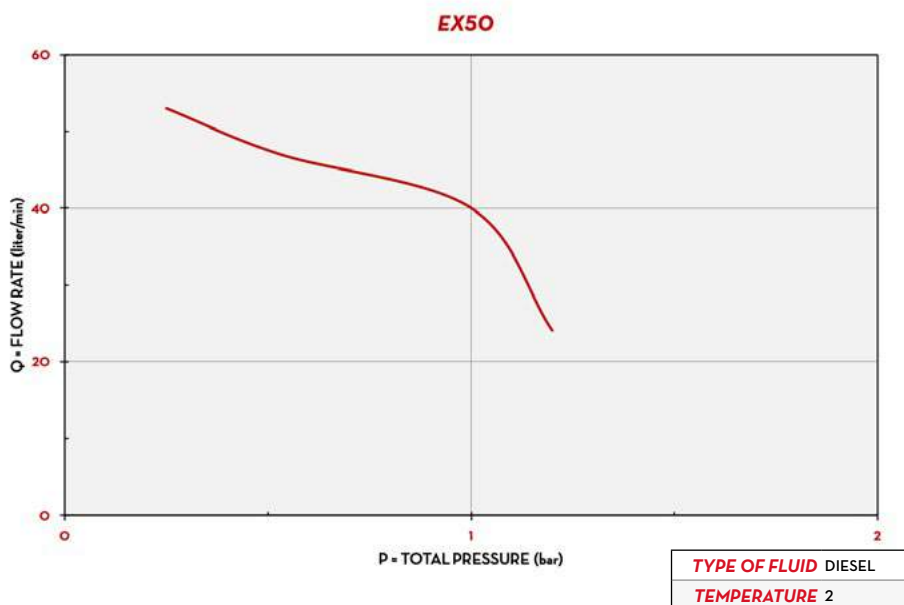

IN THE BOX

- EX50 PUMP
- METALLIC PLATE
- TELESCOPIC SUCTION HOSE
- GASOLINE HOSE
- FILTER
- NOZZLE
- 2" CONNECTOR
- K33 MECHANICAL METER (ON REQUEST)
- INSTRUCTION MANUAL

DETAILS



DIMENSIONS

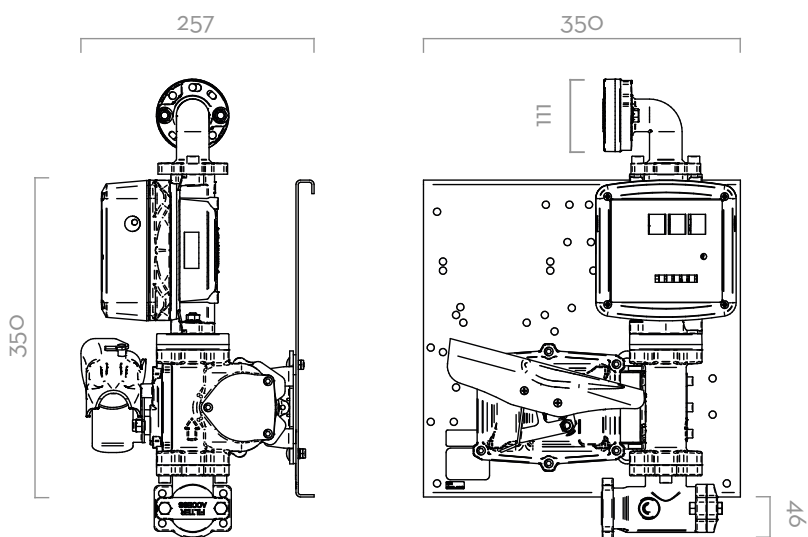

Dimensions expressed in millimeters

COMPONENTS

- **PUMP:**
EX50 PAG. 94
- **METER:**
K33 ATEX PAG. 128
- **NOZZLE:**
A60 ATEX PAG. 156

TECHNICAL DATA

CODE	DESCRIPTION	FLUIDS TYPE	FLOW RATE		VOLTAGE			METER	NOZZLE	FILTER	INLET	HOSE	
			L/MIN	GPM	AC V/HZ	DC VOLT	POWER WATT					AMP. MAX.	BSP
FO0377000	ST EX50 230V K33 ATEX + AUT. NOZZLE	D G K	50	13	230/50-60	250	21	K33	AUT.	-	1"	4	3/4"
FO0377010	ST EX50 230V K33 ATEX + AUT. NOZZLE (RU VERSION)	D G K	50	13	230/50-60	250	21	K33	AUT.	-	1"	4	3/4"

WITH METER

() UPON REQUEST IT IS AVAILABLE WITH DIFFERENT VOLTAGES AND 60 HZ FREQUENCY. COMPATIBLE FLUIDS: DIESEL, KEROSENE, PETROL, PETROL ALCOHOL MIXED MAX 15%, AVGAS 100/100LL (ONLY PUMP&METER), JET A/A1 (ONLY PUMP&METER) - ASPEN 2/4

EX50 ST



FUEL MANAGEMENT SYSTEMS



DISPENSERS



KITS



PUMPS



METERS



NOZZLES

DRUM

FEATURES

- EASY TO INSTALL
- SUITABLE FOR ALL DRUMS
- DIFFERENT PUMPS FOR ANY NEED
- AC/DC VERSIONS

The PIUSI DRUM is a compact fuel transfer unit suitable to be connected on drums thanks to the quick 2" coupling. Available with different pumps, the system is (always) equipped with a telescopic suction hose and the nozzle holder located above the drum, near the pump, for easy, clean and safe operations. K33 mechanical meter available on request.

PERFORMANCE

UP TO

80 L/MIN

FLOW RATE

AC/DC

VOLTAGE

POWER

± 1%

ACCURACY



DRUM PANTHER 56 K33



DRUM BIPUMP 12V



PACKAGING

CODE		WEIGHT		PACKAGING		
WITHOUT METER	WITH METER	KG	LBS	MM	INCH	PCS/BOX
OO0271P00	OO0272P00	13,5	29,8	480X370X265	18,3X14,6X10,4	1
OO0273P00	OO0274P00	14,4	31,7	480X370X265	18,3X14,6X10,4	1
FO022201A	FO022205A	20,7	45,6	480X370X265	18,3X14,6X10,4	1
FO022202A	FO022206A	20,7	45,6	480X370X265	18,3X14,6X10,4	1
FO022203A	FO022207A	21,6	47,6	480X370X265	18,3X14,6X10,4	1
FO022204A	FO022208A	21,6	47,6	480X370X265	18,3X14,6X10,4	1
-	FO034111C	14,7	31,7	480X370X265	18,3X14,6X10,4	1



FILTRATION



TANK MONITORING



HOSE REEL



ACCESSORIES



MERCHANDISE

INDEX



AIR



ANTIFREEZE



AdBlue®



BIODIESEL



DIESEL



FOOD



GASOLINE



GREASE



KEROSENE



OIL



WATER



WINDSCREEN

CHART

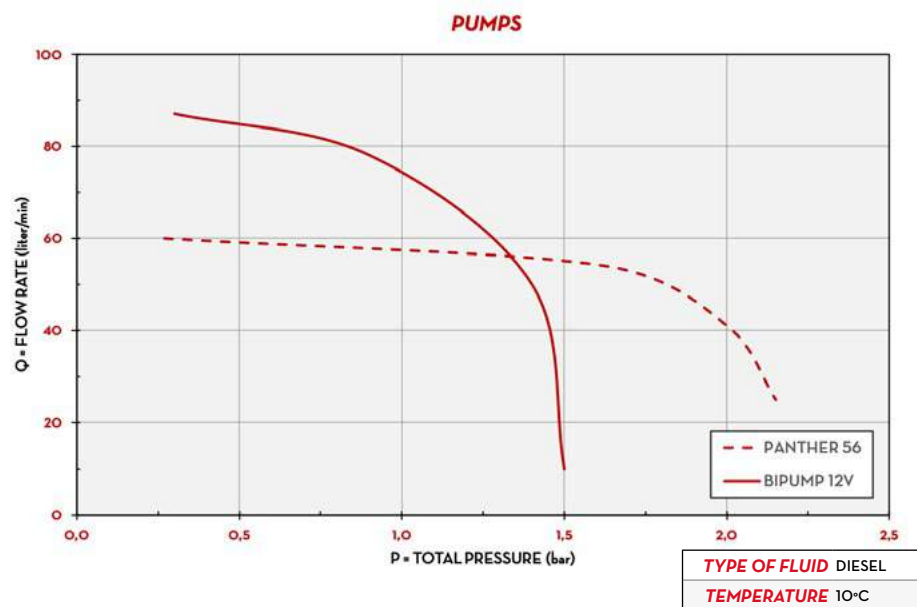

DIMENSIONS

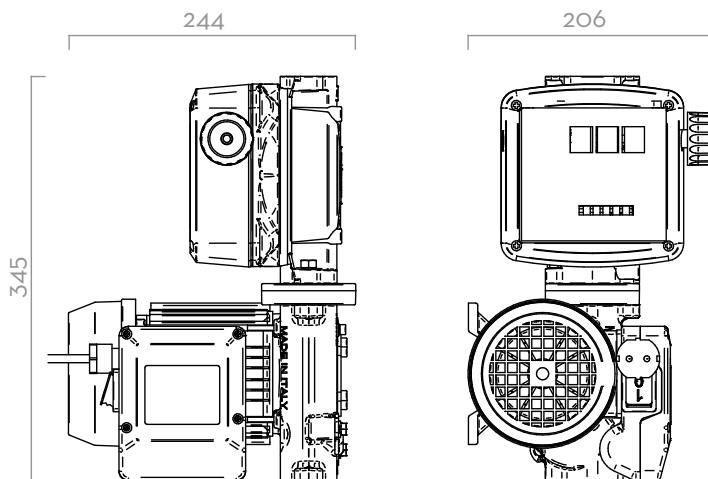

Dimensions expressed in millimeters

IN THE BOX

- PUMP
- TELESCOPIC SUCTION PIPE
- DELIVERY HOSE
- NOZZLE
- 2" CONNECTOR
- K33 MECHANICAL METER (ON REQUEST)
- INSTRUCTION MANUAL

DETAILS



2" CONNECTOR



TELESCOPIC SUCTION HOSE



ELECTRIC CABLE WITH CLAMPS (ONLY DC VERSION)

COMPONENTS

- **PUMPS:**
 - PANTHER AC PAG. 102
 - BIPUMP PAG. 116
 - PANTHER DC PAG. 114
- **METER:**
 - K33 PAG. 146

TECHNICAL DATA

CODE		DESCRIPTION	FLUIDS TYPE	FLOW RATE		VOLTAGE			METER	NOZZLE	INLET	HOSE
WITHOUT METER	WITH METER			L/MIN	GPM	AC V./HZ DC VOLT	POWER WATT	AMP. MAX.				
OOO271POO	OOO272POO	DRUM PANTHER 56	D	56	15	230/50	350	3	K33	SELF2000	3/4"	4M
OOO273POO	OOO274POO	DRUM PANTHER 56 A6O	D	56	15	230/50	350	3	K33	A6O	3/4"	4M
FOO222O1A	FOO222O5A	DRUM BIPUMP 12V	D	80	21	12V	530	44	K33	SELF2000	1"	4M
FOO222O2A	FOO222O6A	DRUM BIPUMP 24V	D	80	21	24V	540	22,5	K33	SELF2000	1"	4M
FOO222O3A	FOO222O7A	DRUM BIPUMP 12V A12O	D	80	21	12V	530	44	K33	A12O	1"	4M
FOO222O4A	FOO222O8A	DRUM BIPUMP 24V A12O	D	80	21	24V	540	22,5	K33	A12O	1"	4M
-	FOO3411IC	DRUM PANTHER DC 24/12V K33 A6O	D	56	15	24/12V	150	25/16A	K33	A6O	3/4"	4M



FUEL MANAGEMENT SYSTEMS



DISPENSERS



KITS



PUMPS



METERS



NOZZLES

PICO

FEATURES

- **READY TO USE**
- **TURBINE FLOW-METER (K24 VERSION ONLY)**
- **WEATHER PROOF MATERIALS**
- **STURDY DESIGN**

The PIUSI PICO is a dispensing unit suitable to transfer diesel, antifreeze and windscreen. It includes a centrifugal pump ready to be fit on any kind of drum (vertical installation with built-in connection). K24 meter and automatic nozzle available on request.

PERFORMANCE

UP TO

35 L/MIN

FLOW RATE

AC/DC

VOLTAGE

POWER

± 1%

ACCURACY



PACKAGING

CODE	WEIGHT		PACKAGING		
	KG	LBS	MM	INCH	PCS/BOX
WITH METER					
FO0202020	4,8	10,6	360X360X180	14,2X14,2X7,1	1
FO0202030	5,8	12,8	360X360X180	14,2X14,2X7,1	1
FO0202060	4,8	10,6	360X360X180	14,2X14,2X7,1	1
FO0202070	5,8	12,8	360X360X180	14,2X14,2X7,1	1
FO0202100	4,8	10,6	360X360X180	14,2X14,2X7,1	1
FO0202110	5,8	12,8	360X360X180	14,2X14,2X7,1	1
WITHOUT METER					
FO0202000	4,8	10,6	360X360X180	14,2X14,2X7,1	1
FO0202010	5,8	12,8	360X360X180	14,2X14,2X7,1	1
FO0202040	4,8	10,6	360X360X180	14,2X14,2X7,1	1
FO0202050	5,8	12,8	360X360X180	14,2X14,2X7,1	1
FO0202080	4,8	10,6	360X360X180	14,2X14,2X7,1	1
FO0202090	5,8	12,8	360X360X180	14,2X14,2X7,1	1



FILTRATION



TANK MONITORING



HOSE REEL



ACCESSORIES



MERCHANDISE

INDEX



AIR



ANTIFREEZE



AdBlue®



BIODIESEL



DIESEL



FOOD



GASOLINE



GREASE



KEROSENE



OIL



WATER



WINDSCREEN

CHART

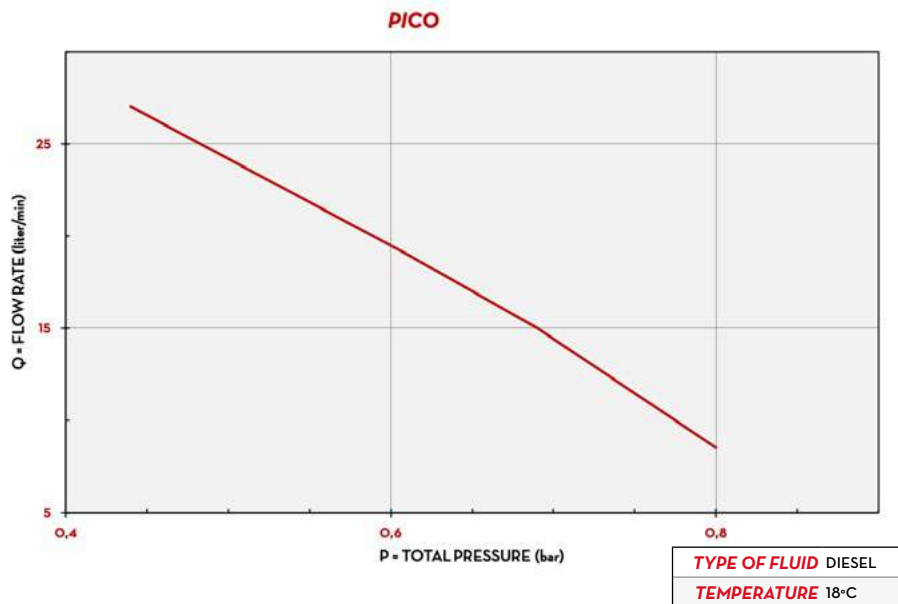

DIMENSIONS

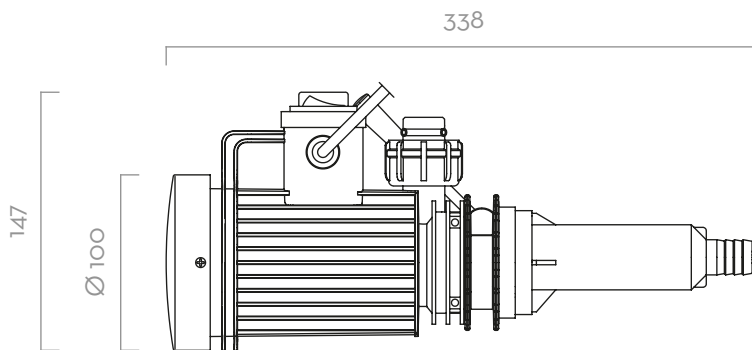

Dimensions expressed in millimeters

TECHNICAL DATA

CODE	DESCRIPTION	FLUIDS TYPE	FLOW RATE		VOLTAGE			PUMP TYPE	DUTY CYCLE MINUTES	NOZZLE TYPE	HOSE		FOOT FILTER
			L/MIN	GPM	AC V./HZ DC VOLT	POWER WATT	AMP. MAX.				LENGTH	Ø	
WITH METER													
FO0202020	PICO 230 K24 M	A D W	35	9	230/50	224	1	PICO	-	MAN.	4M	3/4"	YES
FO0202030	PICO 230 K24 A	A D W	30	8	230/50	224	1	PICO	-	AUT.	4M	3/4"	YES
FO0202060	PICO 12 K24 M	A D W	30	8	12	110	9	PICO	30	MAN.	4M	3/4"	YES
FO0202070	PICO 12 K24 A	A D W	25	7	12	110	9	PICO	30	AUT.	4M	3/4"	YES
FO0202100	PICO 24 K24 M	A D W	30	8	24	135	5,5	PICO	30	MAN.	4M	3/4"	YES
FO0202110	PICO 24 K24 A	A D W	25	7	24	135	5,5	PICO	30	AUT.	4M	3/4"	YES
WITHOUT METER													
FO0202000	PICO 230 M	A D W	35	9	230/50	224	1	PICO	-	MAN.	4M	3/4"	YES
FO0202010	PICO 230 A	A D W	30	8	230/50	224	1	PICO	-	AUT.	4M	3/4"	YES
FO0202040	PICO 12 M	A D W	30	8	12	110	9	PICO	30	MAN.	4M	3/4"	YES
FO0202050	PICO 12 A	A D W	25	7	12	110	9	PICO	30	AUT.	4M	3/4"	YES
FO0202080	PICO 24 M	A D W	30	8	24	135	5,5	PICO	30	MAN.	4M	3/4"	YES
FO0202090	PICO 24 A	A D W	25	7	24	135	5,5	PICO	30	AUT.	4M	3/4"	YES

IN THE BOX

- PICO UNIT
- DELIVERY HOSE
- SUCTION PIPE
- MANUAL/AUTOMATIC NOZZLE
- METER (ON REQUEST)
- INSTRUCTION MANUAL

DETAILS



ON/OFF SWITCH



VERSION WITH METER



ELECTRIC CABLE WITH CLAMPS (ONLY DC VERSION)

MATERIALS

- BODY: TECHNOPYLIMER
- TURBINES: TECHNOPYLIMER



FUEL MANAGEMENT
SYSTEMS



DISPENSERS



KITS



PUMPS



METERS



NOZZLES

BATTERY KIT

FEATURES

- VERSATILITY
- MOBILE AND READY TO USE
- ON/OFF SWITCH

The PIUSI BATTERY KIT is a portable transfer unit with a self-priming electric vane pump. Its modular composition allows users to have different pumps according to the required flow rates and different applications. It is equipped with a fixed brush motor with permanent magnet stator and terminal board with switches and fuses to protect against overload. It is always supplied with integrated nozzle and a set of accessories.

PERFORMANCE

UP TO 80 L/MIN	12/24V
FLOW RATE	VOLTAGE POWER
30 MIN	UP TO 2MT
DUTY CICLE	SELF-PRIMING



BATTERY KIT 3000



PACKAGING

CODE	WEIGHT		PACKAGING			N. BOXES / EUROPALLET	
	KG	LBS	MM	INCH	PCS/BOX	✕	
BATTERY KIT 3000							
FO022500C	7,8	17,3	300X300X180	-	1	50	100
FO022600C	7,8	17,3	300X300X180	-	1	50	100
FO0225410	7,8	17,3	300X300X180	-	1	50	100
FO0226380	7,8	17,3	300X300X180	-	1	50	100
BATTERY KIT PANTHER							
FO034003B	7,8	17,3	300X300X180	-	1	24	36
FO034103C	7,8	17,3	300X300X180	-	1	24	36
FO034006B	12,5	27,6	330057X357X275	-	1	24	36
FO0341220	13	28,7	357X357X275	-	1	24	36
FO034106C	12,5	27,6	357X357X275	-	1	24	36
BATTERY KIT BIPUMP							
FO0363280	18	39,7	480X370X265	-	1		
BATTERY KIT OIL							
FO0309060	7,8	17,3	300X300X180	-	1	50	100
FO0310070	7,8	17,3	300X300X180	-	1	50	100



FILTRATION



TANK MONITORING



HOSE REEL



ACCESSORIES



MERCHANDISE

INDEX



AIR



ANTIFREEZE



AdBlue®



BIODIESEL



DIESEL



FOOD



GASOLINE



GREASE



KEROSENE



OIL



WATER



WINDSCREEN



BATTERY KIT BIPUMP



BATTERY KIT 3000 INLINE



BATTERY KIT OIL



BATTERY KIT PANTHER

IN THE BOX

- PUMP
- SUCTION HOSE
- DELIVERY HOSE
- HANDLE
- NOZZLE
- MESH FILTER AND CONNECTIONS
- CABLES
- INSTRUCTION MANUAL

DETAILS



ON/OFF SWITCH



HANDLE



ELECTRIC CABLE WITH CLAMPS

COMPONENTS

- DEPENDING ON PUMP MODEL, SEE REFERRED PAGES

TECHNICAL DATA

CODE	DESCRIPTION	FLUIDS TYPE	FLOW RATE		VOLTAGE			FUSES CAPACITY	PUMP	DUTY CYCLE	NOZZLE	HOSE		CHECK FILTER	
			L/MIN	GPM	AC V./HZ DC VOLT	POWER WATT	AMP. MAX.	AMPERE				TYPE	MINUTES		TYPE
BATTERY KIT 3000															
FOO22500C	BATTERY KIT 3000 12V	D	50	13	12	220	22	25	BP3000	CAT. FUEL PAG. 112	30	SELF 2000	4M	3/4"	YES
FOO22600C	BATTERY KIT 3000 24V	D	50	13	24	310	13	15	BP3000	CAT. FUEL PAG. 112	30	SELF 2000	4M	3/4"	YES
FOO225410	BATTERY KIT 3000 INLINE 12V	D	50	13	12	220	22	25	BP3000	CAT. FUEL PAG. 112	30	SELF 2000	4M	3/4"	YES
FOO226380	BATTERY KIT 3000 INLINE 24V	D	50	13	24	310	13	15	BP3000	CAT. FUEL PAG. 112	30	SELF 2000	4M	3/4"	YES
BATTERY KIT PANTHER															
FOO34003B	BATTERY KIT PANTHER 12V	D	56	15	12	300	35	40	PANTHER DC	CAT. FUEL PAG. 114	30	SELF 2000	4M	3/4"	YES
FOO34103C	BATTERY KIT PANTHER 12-24V	D	35/70	9/18	24/12	420/150	25/16	30	PANTHER DC	CAT. FUEL PAG. 114	30	SELF 2000	4M	3/4"	YES
FOO34006B	BATTERY KIT PANTHER 12V	D	56	15	12	420	35	40	PANTHER DC	CAT. FUEL PAG. 114	30	SELF 2000	5M	3/4"	YES
FOO341220	BATTERY KIT PANTHER 12-24V	D	35/70	9/18	12/24	600/200	25/16	30	PANTHER DC	CAT. FUEL PAG. 114	30	A60	5M	3/4"	YES
FOO34106C	BATTERY KIT PANTHER 12-24V	D	35/70	9/18	12/24	600/200	25/16	30	PANTHER DC	CAT. FUEL PAG. 114	30	SELF 2000	5M	3/4"	YES
BATTERY KIT BIPUMP															
FOO363280	BATTERY KIT BIPUMP 12V	D	80	21	12	300	22	40	BIPUMP DC	CAT. FUEL PAG. 116	30	A120	6M	3/4"	YES
BATTERY KIT OIL															
FOO309060	BATTERY KIT VISCOMAT 12V	O	10	3	12	300	22	40	VISCOMAT DC	CAT. LUBE PAG. 38	30	SELF 3000	4M	3/4"	YES
FOO310070	BATTERY KIT VISCOMAT 24V	O	10	3	24	300	18	30	VISCOMAT DC	CAT. LUBE PAG. 38	30	SELF 3000	4M	3/4"	YES

BATTERY KIT



FUEL MANAGEMENT SYSTEMS



DISPENSERS



KITS



PUMPS



METERS



NOZZLES

PITSTOP

FEATURES

- **READY TO INSTALL**
- **VERSATILITY**
- **STURDY STRUCTURE**

The PIUSI PITSTOP is a dispenser unit with two DC pumps, automatic hose reel, water filter and automatic nozzle with 14 meter. hose integrated into a sturdy supporting structure. Easy to install, versatile and compact, this dispenser is the all-in-one solution for setting up a perfect mobile refueling unit.

PERFORMANCE

UP TO

45 L/MIN

FLOW RATE

12/24V

VOLTAGE

POWER

14MT

HOSE LENGTH

HOSE REEL

200β/30μ

FILTERING CAPACITY



PITSTOP



PACKAGING

CODE	WEIGHT		PACKAGING		
	KG	LBS	MM	INCH	PCS/BOX
FO0212000	45	99	595X465X670	23,4X13,5X24,4	1
FO0213000	45	99	595X465X670	23,4X13,5X24,4	1



FILTRATION



TANK MONITORING



HOSE REEL



ACCESSORIES



MERCHANDISE

INDEX



AIR



ANTIFREEZE



AdBlue®



BIODIESEL



DIESEL



FOOD



GASOLINE



GREASE



KEROSENE



OIL



WATER



WINDSCREEN

CHART

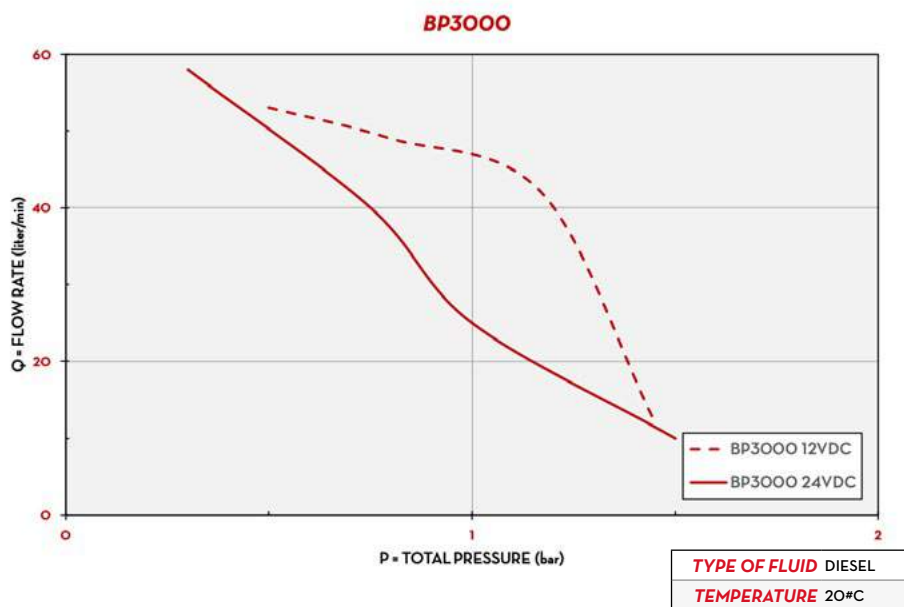

DIMENSIONS

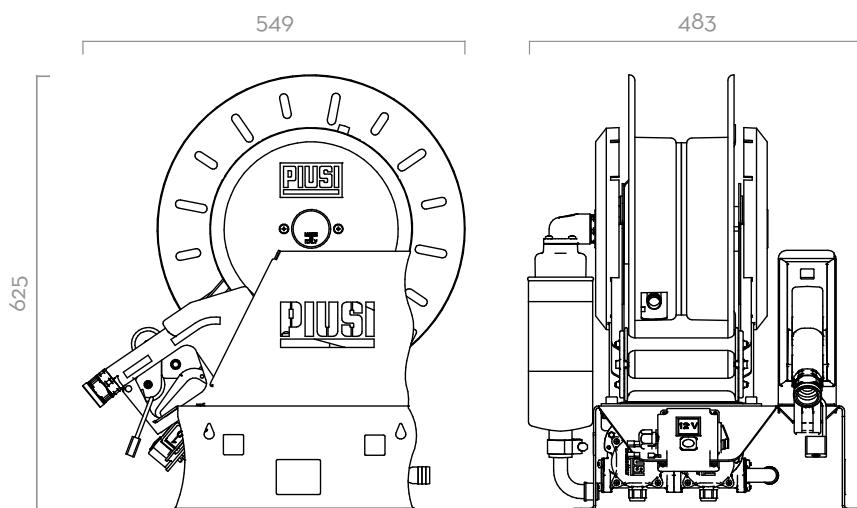

Dimensions expressed in millimeters

IN THE BOX

- PITSTOP UNIT
- AUTOMATIC NOZZLE
- FILTER
- INSTRUCTION MANUAL

DETAILS



ON/OFF SWITCH



PAD LOCK



BUILT-IN DC PUMPS



ADJUSTABLE ARM

COMPONENTS

- **PUMP:**
BP3000 PAG. 112
- **FILTER:**
WATER CAPTOR PAG. 170
- **NOZZLE:**
A60 PAG. 158

TECHNICAL DATA

CODE	DESCRIPTION	FLUIDS TYPE	FLOW RATE		VOLTAGE			PUMP		DUTY CYCLE	NOZZLE	HOSE		INLET	
			L/MIN	GPM	AC V/ HZ	DC VOLT	POWER WATT	AMP. MAX.	TYPE			N°	MINUTES	TYPE	LENGTH
FOO212000	PIUSI PITSTOP DC 12V	D	45	11,9	12	400	33	BP 3000	2	30	A60	14M	3/4"	1"	
FOO213000	PIUSI PITSTOP DC 24V	D	45	11,9	24	620	26	BP 3000	2	30	A60	14M	3/4"	1"	



FUEL MANAGEMENT SYSTEMS



DISPENSERS



KITS



PUMPS



METERS



NOZZLES

PIUSIBOX

FEATURES

- SELF PRIMING PUMP
- BUILT-IN FILTER (PRO VERSION)
- EASY TO REPACK
- IP55

The PIUSIBOX is a portable fuel dispenser integrated with a self-priming transfer pump, filter, check valve and manual nozzle. Suitable for quick and safe refuel operations in all the situations where an easy mobile refueling solution is required.

PERFORMANCE

UP TO

45 L/MIN

FLOW RATE

12/24V

VOLTAGE

POWER

30 MIN

DUTY CICLE



PIUSIBOX



PACKAGING

CODE	WEIGHT		PACKAGING			N. BOXES / EUROPALLET	
	KG	LBS	MM	INCH	PCS/BOX		
FO023100B	9,5	20,9	400X300X420	-	1	24	32
FO023101B	12	26,5	400X300X420	-	1	24	32
FO023200B	9,5	20,9	400X300X420	-	1	24	32
FO023201B	12	26,5	400X300X420	-	1	24	32



FILTRATION



TANK MONITORING



HOSE REEL



ACCESSORIES



MERCHANDISE

INDEX



AIR



ANTIFREEZE



AdBlue®



BIODIESEL



DIESEL



FOOD



GASOLINE



GREASE



KEROSENE



OIL



WATER



WINDSCREEN

CHART

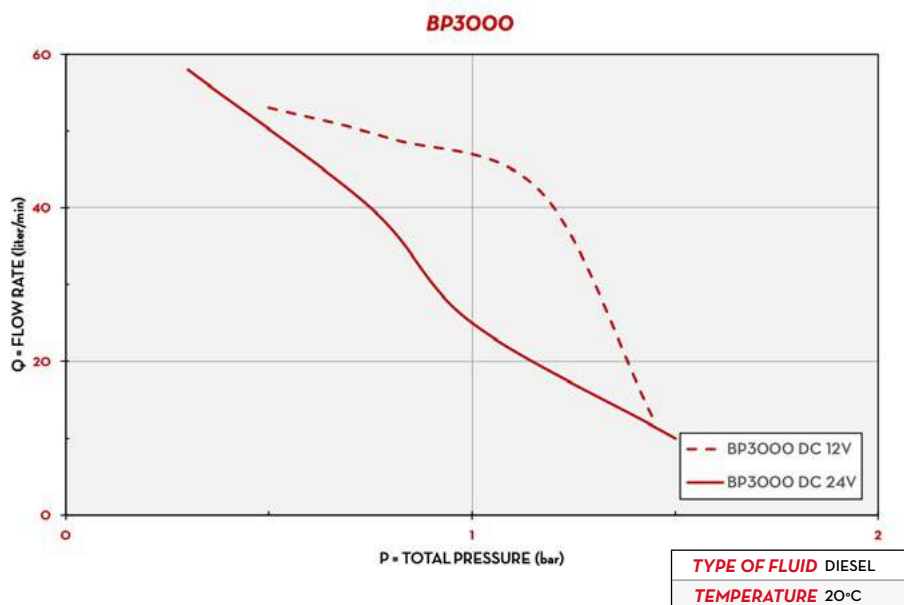

DIMENSIONS

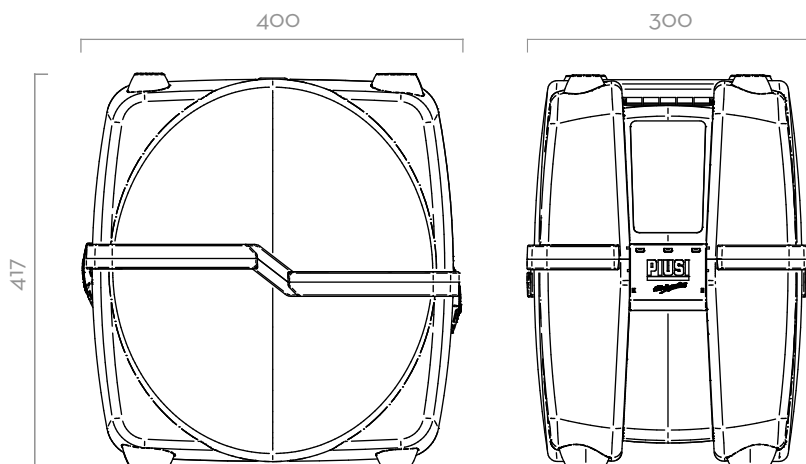

Dimensions expressed in millimeters

IN THE BOX

- PIUSIBOX UNIT
- SUCTION&DELIVERY HOSE
- OIL&FUEL FILTER (PRO VERSION)
- CHECK VALVE
- INSTRUCTION MANUAL

DETAILS



CHECK VALVE



ERGONOMIC HANDLE



ROTATING CONNECTION

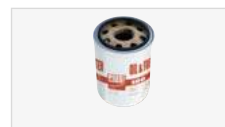

CARTRIDGE (PAG. 90)

MATERIALS

- BODY: CAST IRON
- ROTOR: SINTERED STEEL
- VANES: ACETAL RESIN
- SEAL: NBR
- SHAFT: STEEL

TECHNICAL DATA

CODE	DESCRIPTION	FLUIDS TYPE	FLOW RATE		VOLTAGE			PUMP TYPE	DUTY CYCLE MINUTES	FILTER	CARTRIDGE	NOZZLE TYPE	DELIVERY HOSE 5/8"	SUCTION HOSE 3/4"	FOOT VALVE MOD. VANTAGE
			L/MIN	GPM	AC V/HZ DC VOLT	POWER WATT	AMP. MAX.								
FOO23100B	PIUSIBOX 12V BASIC	D	45	11,9	12	400	33	BP 3000	30	NO	NO	MAN.	4M	2M	YES
FOO23101B	PIUSIBOX 12V PRO	D	43	11,7	12	620	26	BP 3000	30	YES	10μ	MAN.	4M	2M	YES
FOO23200B	PIUSIBOX 24V BASIC	D	45	11,9	24	400	33	BP 3000	30	NO	NO	MAN.	4M	2M	YES
FOO23201B	PIUSIBOX 24V PRO	D	43	11,7	24	620	26	BP 3000	30	YES	10μ	MAN.	4M	2M	YES



FUEL MANAGEMENT SYSTEMS



DISPENSERS



KITS



PUMPS



METERS



NOZZLES

CARRY

FEATURES

- EASY TO INSTALL
- SAFE TO MOVE
- LONG LASTING APPLICATION

The PIUSI CARRY pump is a diesel transfer DC pump designed to meet the needs of those who are looking for a long-lasting, high quality and portable pump. CARRY 3000 is equipped with a sturdy handle to allow easy carriage and comes complete with dispensing pipe, power cables and the dispensing nozzle.

PERFORMANCE

UP TO
70 L/MIN

FLOW RATE

12/24V

VOLTAGE
POWER

30 MIN

DUTY CICLE



CARRY PANTHER

CARRY



CARRY 3000 INLINE

PACKAGING

CODE	WEIGHT		PACKAGING			N. BOXES / EUROPALLET	
	KG	LBS	MM	INCH	PCS/BOX	✕	
FO022300C	4,2	9,3	260X235X164	-	1	84	120
FO022400C	4,2	9,3	260X235X164	-	1	84	120
FO0223260	4,2	9,3	260X235X164	-	1	84	120
FO0224240	4,2	9,3	260X235X164	-	1	84	120
FO034004B	4,2	9,3	260X235X164	-	1	84	120
FO034104C	4,2	9,3	260X235X164	-	1	84	120



FILTRATION



TANK MONITORING



HOSE REEL



ACCESSORIES



MERCHANDISE

INDEX



AIR



ANTIFREEZE



AdBlue®



BIODIESEL



DIESEL



FOOD



GASOLINE



GREASE



KEROSENE



OIL



WATER



WINDSCREEN

CHART

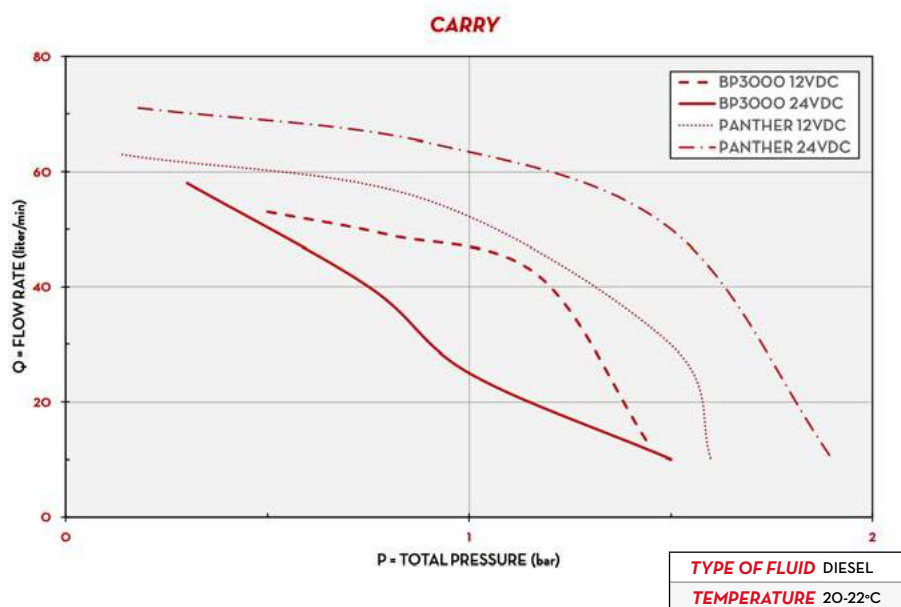

IN THE BOX

- CARRY PUMP
- HANDLE
- DISPENSING PIPE
- ELECTRIC CABLE WITH CLAMPS
- CONNECTIONS
- INSTRUCTION MANUAL

DETAILS



DIMENSIONS

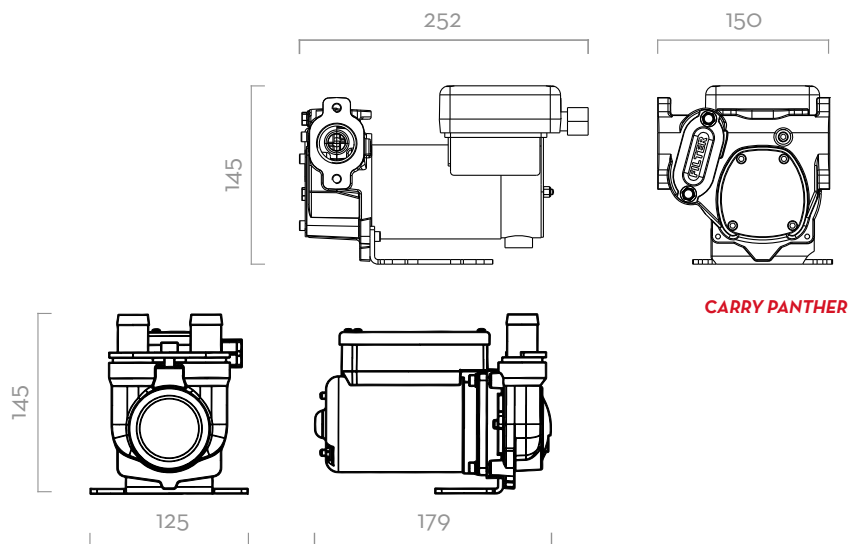

Dimensions expressed in millimeters

MATERIALS

- BODY: CAST IRON
- ROTOR: SINTERED STEEL
- VANES: ACETAL RESIN
- SEAL: NBR
- SHAFT: STEEL

TECHNICAL DATA

CODE	DESCRIPTION	FLUIDS TYPE	FLOW RATE		VOLTAGE			FUSES CAPACITY	DUTY CYCLE	RPM	PRESSURE MAX	ON/OFF SWITCH	INLET/OUTLET
			L/MIN	GPM	DC VOLT	POWER WATT	AMP. MAX.						
FOO22300C	CARRY 3000 12V	D	50	13	12	300	24	25	30	2900	1,5	YES	3/4"
FOO22400C	CARRY 3000 24V / 12V	D	50/30	13/6	24/12	310/80	13/6,5	15	30	2900/1500	1,5	YES	3/4"
FOO223260	CARRY 3000 INLINE 12V	D	50	13	12	300	24	25	30	2900	1,5	YES	3/4"
FOO224240	CARRY 3000 INLINE 24V	D	50/30	13/6	24/12	310/80	24	15	30	2900/1500	1,5	YES	3/4"
FOO34004B	CARRY PANTHER 12V	D	56	15	12	420	13/6,5	40	30	2900	-	YES	1"
FOO34104C	CARRY PANTHER 12V / 24V	D	35/70	9/18	24/12	600/200	13/6,5	30	30	3500/1800	-	YES	1"

CARRY



FUEL MANAGEMENT SYSTEMS



DISPENSERS



KITS



PUMPS



METERS



NOZZLES

ST

FEATURES

- RAY TO USE
- EASY TO INSTALL
- STURDY STRUCTURE
- COMPACT DESIGN
- AVAILABLE WITH DIFFERENT PUMPS

The PIUSI ST is a versatile and compact diesel transfer station that can be used to fill mobile tanks or interact with distribution units. It is fitted with check valve, filter, nozzle and 4mt delivery hose. Its sturdy structure makes this dispenser suitable to be used in the harshest environments. It can be integrated with a protective metal box and water separating filter.

PERFORMANCE

UP TO

90 L/MIN

FLOW RATE

AC/DC

VOLTAGE

POWER

4MT

LENGTH

DELIVERY HOSE

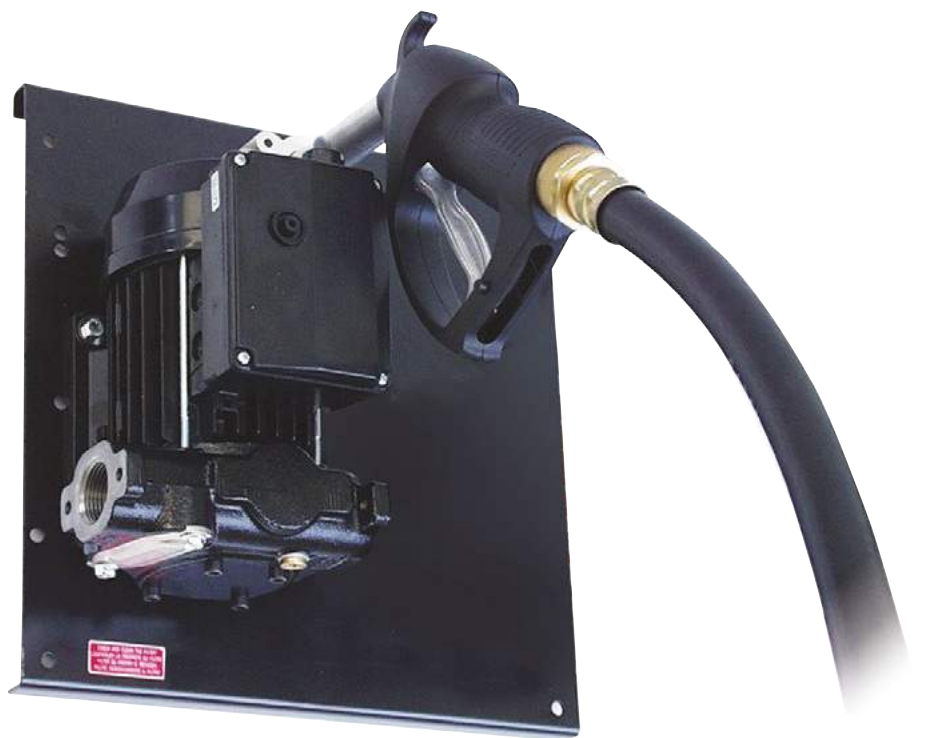

ST



PACKAGING

CODE	WEIGHT		PACKAGING		
	KG	LBS	MM	INCH	PCS/BOX
000266P00	16	35	357X357X275	14,1X14,1X10,8	1
000286P00	16	35	357X357X275	14,1X14,1X10,8	1
000266P20	21	46	357X357X275	14,1X14,1X10,8	1
000214000	21	46	357X357X275	14,2X14,2X11,8	1
000216000	23	50	480X370X265	18,9X14,6X10,4	1
000252000	23	50	480X370X265	18,9X14,6X10,4	1
FO021000B	10	22	357X357X275	14,1X14,1X10,8	1
FO021100B	10	22	357X357X275	14,1X14,1X10,8	1
FO0340080	19	42	357X357X275	14,1X14,1X10,8	1



FILTRATION



TANK MONITORING



HOSE REEL



ACCESSORIES



MERCHANDISE

INDEX



AIR



ANTIFREEZE



AdBlue®



BIODIESEL



DIESEL



FOOD



GASOLINE



GREASE



KEROSENE



OIL



WATER



WINDSCREEN

AVAILABLE WITH DIFFERENT PUMPS



AC PUMP - PANTHER



AC PUMP - E80



AC PUMP - E120



AC PUMP - VISCOMAT VANE



DC PUMP - BP3000



DC PUMP - PANTHER DC

DIMENSIONS

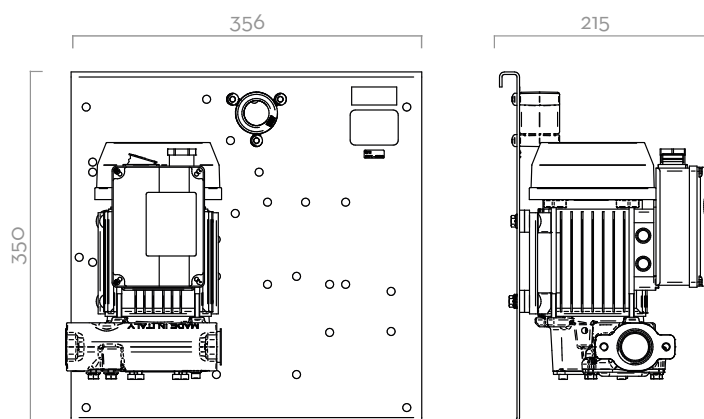

Dimensions expressed in millimeters

IN THE BOX

- ST UNIT
- DELIVERY HOSE
- NOZZLE
- NOZZLE HOLDER
- INSTRUCTION MANUAL

DETAILS



MANUAL NOZZLE (pag. 162)



AUTOMATIC NOZZLE (pag. 158)

COMPONENTS

- PUMPS:

PANTHER AC	PAG. 102
E80/E120	PAG. 106
VISCOMAT VANE	PAG. 104
BP3000	PAG. 112
PANTHER DC	PAG. 114
- NOZZLE:

MANUAL NOZZLE	PAG. 162
AUTOMATIC NOZZLE	PAG. 158

TECHNICAL DATA

CODE	DESCRIPTION	FLUIDS TYPE	FLOW RATE		VOLTAGE			METER	NOZZLE	FILTER	DELIVERY HOSE		OUTLET
			L/MIN	GPM	AC V/ HZ DC VOLT	POWER WATT	AMP. MAX.				LENGTH	Ø	
000266P00	ST PANTHER 56	D	56	15	230/50	350	3	NO	SELF 3000	NO	4M	3/4"	1"
000286P00	ST PANTHER 56 A60	D	56	15	230/50	350	3	NO	A60	NO	4M	3/4"	1"
000266P20	ST PANTHER 72/M	D	72	19	230/50	500	4,2	NO	SELF 3000	NO	4M	3/4"	1"
000214000	ST E 80	D	80	21	230/50	700	3,5	NO	SELF 3000	NO	4M	1"	1"
000216000	ST E 120	D	90	24	230/50	1150	5,7	NO	SELF 3000	NO	4M	1"	1"
000252000	ST E 120 A120	D	90	24	230/50	1150	5,7	NO	A120	NO	4M	1"	1"
FOO21000B	ST BYPASS 3000 12V	D	42	11	12	260	22	NO	SELF 3000	NO	4M	3/4"	1"
FOO21100B	ST BYPASS 3000 24V	D	42	11	24	300	12	NO	SELF 3000	NO	4M	3/4"	1"
FOO340080	ST PANTHER DC 12V	D	56	15	12	420	35	NO	SELF 3000	NO	4M	3/4"	1"

THE UNIT CAN ALSO BE SUPPLIED FOR OPERATING UNDER DIFFERENT VOLTAGES AND WITHOUT METER.



FUEL MANAGEMENT SYSTEMS



DISPENSERS



KITS



PUMPS



METERS



NOZZLES

ST WITH METER

FEATURES

- **READY TO USE**
- **EASY TO INSTALL**
- **STURDY STRUCTURE**
- **HIGH PRECISION METER**
- **AVAILABLE WITH DIFFERENT PUMPS**

The PIUSI ST WITH METER is a diesel transfer station for fixed installations composed by AC or DC pump, nozzle (manual or automatic) and precision meter - both mechanical (K33) or electronic (K600 B/3) - for safe and controlled refueling operations. Easy to install, this station can be used to fill mobile tanks or interact with distribution units.

PERFORMANCE

UP TO

90 L/MIN

FLOW RATE

AC/DC

VOLTAGE

POWER

± 1%

ACCURACY

4MT

LENGTH

DELIVERY HOSE

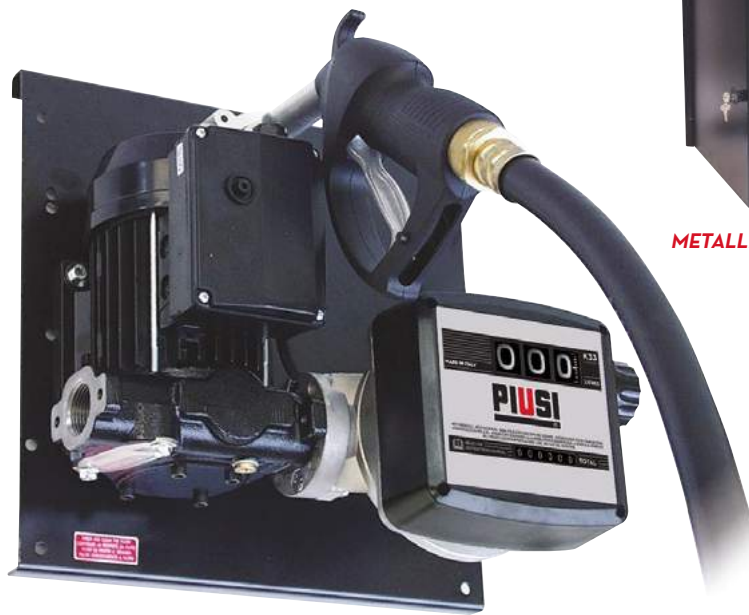

ST WITH METER



METALLIC BOX (optional)



PACKAGING

CODE	WEIGHT		PACKAGING		
	KG	LBS	MM	INCH	PCS/BOX
FO0385POA	16	35	357X357X275	14,1X14,1X10,8	1
FO0287POA	16	35	357X357X275	14,1X14,1X10,8	1
OO0390000	21	46	357X357X275	14,1X14,1X10,8	1
OO0392000	23	50	357X357X275	14,2X14,2X11,8	1
OO0395000	23	50	480X370X265	18,9X14,6X10,4	1
OO0395050	24	53	480X370X275	18,9X14,6X11,8	1
OO0397000	20	44	480X370X265	18,9X14,6X10,4	1
OO0287P40	19	41	357X357X275	14,1X14,1X10,8	1
FO023500B	13	29	357X357X275	14,1X14,1X10,8	1
FO023600B	13	29	357X357X275	14,2X14,2X11,8	1
FO023300B	14	31	480X370X265	18,9X14,6X10,4	1
FO023400B	14	31	480X370X265	18,9X14,6X10,4	1
FO024000A	24	53	357X357X275	14,1X14,1X10,8	1
FO024003A	24	53	357X357X275	14,1X14,1X10,8	1
FO024100A	24	53	357X357X275	14,1X14,1X10,8	1
FO024101A	11	11	357X357X275	14,1X14,1X10,8	1
FO0340070	17	37	357X357X275	14,1X14,1X10,8	1
FO0340160	17	11	357X357X275	14,1X14,1X10,8	1



FILTRATION



TANK MONITORING



HOSE REEL



ACCESSORIES



MERCHANDISE

INDEX



AIR



ANTIFREEZE



AdBlue®



BIODIESEL



DIESEL



FOOD



GASOLINE



GREASE



KEROSENE



OIL



WATER



WINDSCREEN

AVAILABLE WITH DIFFERENT PUMPS



AC PUMP - PANTHER 56/72



AC PUMP - E80/E120



AC PUMP - VISCOMAT 70/90



DC PUMP - BYPASS 3000



DC PUMP - PANTHER DC



DC PUMP - BIPUMP

DIMENSIONS

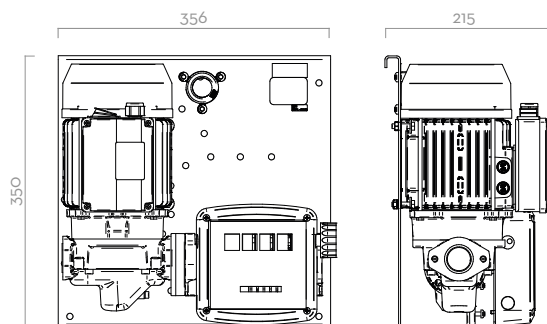

Dimensions expressed in millimeters

IN THE BOX

- ST WITH METER UNIT
- METER
- DELIVERY HOSE
- NOZZLE
- NOZZLE HOLDER
- INSTRUCTION MANUAL

DETAILS



K33 / K600 B/3



MAN. / AUTOM. NOZZLE

COMPONENTS

- **PUMPS:**
 - PANTHER AC PAG. 102
 - E80/E120 PAG. 106
 - VISCOMAT VANE PAG. 104
 - BP3000 PAG. 112
 - PANTHER DC PAG. 114
 - BIPUMP PAG. 116
- **NOZZLE:**
 - MANUAL NOZZLE PAG. 162
 - AUTOMATIC NOZZLE PAG. 158
- **METERS:**
 - K33 PAG. 128
 - K600 B/3 PAG. 136

TECHNICAL DATA

CODE	DESCRIPTION	FLUIDS TYPE	FLOW RATE		VOLTAGE			METER	NOZZLE	SUCTION HOSE	HOSE		OUTLET
			L/MIN	GPM	AC V/HZ DC VOLT	POWER WATT	AMP. MAX.				LENGTH (M)	Ø (MM)	
FOO385POA	ST PANTHER 56 K33	D	56	15	230/50	350	3	K33	SELF 3000	NO	4	20	3/4"
FOO287POA	ST PANTHER 56 K33 A60	D	56	15	230/50	350	3	K33	A60	NO	4	20	3/4"
OOO390000	ST E80 K33	D	80	21	230/50	700	3,5	K33	SELF 3000	NO	4	25	1"
OOO392000	ST E80 K33 A80	D	75	20	230/50	700	3,5	K33	A80	NO	4	25	1"
OOO395000	ST E120 K33	D	90	24	230/50	1150	5,7	K33	SELF 3000	NO	4	25	1"
OOO395050	ST E120/M K44	D	90	24	230/50	1150	5,7	K44	SELF 3000	NO	4	25	1"
OOO397000	ST E120 K33 A120	D	90	24	230/50	1150	5,7	K33	A120	NO	4	25	1"
OOO287P40	ST PANTHER 72/M K33 A80	D	72	19	230/50	500	4,2	K33	A80	NO	4	25	1"
FOO23500B	ST BYPASS 3000/12V K33	D	40	10	12	260	22	K33	SELF 3000	NO	4	20	3/4"
FOO23600B	ST BYPASS 3000 INLINE 24V K33	D	40	10	24	300	12	K33	SELF 3000	NO	4	20	3/4"
FOO23300B	ST BYPASS 3000/12V K33 A60	D	35	9	12	260	22	K33	A60	NO	4	20	3/4"
FOO23400B	ST BYPASS 3000 INLINE 24V K33 A60	D	35	9	24	300	12	K33	A60	NO	4	20	3/4"
FOO24000A	ST BIPUMP 12V K33 SELF 3000	D	80	21	12	530	44	K33	SELF 3000	NO	4	25	1"
FOO24003A	ST BIPUMP 12V K33 A120	D	80	21	12	530	44	K33	A120	NO	4	25	1"
FOO24100A	ST BIPUMP 24V K33 SELF 3000	D	80	21	24	540	22,5	K33	SELF 3000	NO	4	25	1"
FOO24101A	ST BIPUMP 24V K33 A120	D	80	21	24	540	22,5	K33	A120	NO	4	25	1"
FOO340070	ST PANTHER 12V K33 A60	D	56	15	12	420	35	K33	A60	NO	4	20	3/4"
FOO340160	ST PANTHER DC 12/24V K33 A60	D	70/35	18,5/9,2	24/12	420/150	25/16	K33	A60	NO	4	20	3/4"

ST WITH METER



FUEL MANAGEMENT SYSTEMS



DISPENSERS



KITS



PUMPS



METERS



NOZZLES

ST WITH METER AND FILTER

FEATURES

- **READY TO USE**
- **VERSATILE**
- **EASY TO INSTALL**
- **COMPACT DESIGN**
- **FILTRATION GUARANTEED**
- **AVAILABLE WITH DIFFERENT PUMPS**

PIUSI ST WITH METER AND FILTER is a range of dispensers particularly suited for all applications in which a filtration is required. The stations integrate PIUSI CLEAR or WATER CAPTOR FILTERS and are available with mechanical meter K33 or electronic meter K24/K600 B/3. They come with integrated check valve and 4-meter delivery hose.

PERFORMANCE

UP TO

90 L/MIN

FLOW RATE

AC

CONTINUOUS DUTY

POWER

± 1%

ACCURACY

UP TO

6MT

LENGTH

DELIVERY HOSE



ST PANTHER 56, K33, A60 AND WATER CAPTOR



ST PANTHER 56, K33, A60 AND CLEAR CAPTOR

PACKAGING

CODE	WEIGHT		PACKAGING		
	KG	LBS	MM	INCH	PCS/BOX
FOO386FOA	25	55	580X380X320	22,8X15X12,6	1
FOO265FOA	26	57	580X380X320	22,8X15X12,6	1
FOO395FOA	32	71	545X435X340	21,5X17,1X13,4	1
FOO386F60	22	48	380X380X480	15X15X18,9	1
FOO386R70	22	48	380X380X480	15X15X18,9	1
FOO265F40	26	57	580X380X320	22,8X15X12,6	1
FOO265S80	26	57	580X380X320	22,8X15X12,6	1
FOO395F60	32	71	545X435X340	21,5X17,1X13,4	1
FOO265S20	18	40	480X370X260	18,9X14,6X10,2	1
FOO265R70	18	40	480X370X260	18,9X14,6X10,2	1



FILTRATION



TANK MONITORING



HOSE REEL



ACCESSORIES



MERCHANDISE

INDEX



AIR



ANTIFREEZE



AdBlue®



BIODIESEL



DIESEL



FOOD



GASOLINE



GREASE



KEROSENE



OIL



WATER



WINDSCREEN

AVAILABLE WITH DIFFERENT PUMPS AND METERS



AC PUMP - PANTHER 56/72



AC PUMP - E120



AUTOMATIC NOZZLE

IN THE BOX

- ST WITH METER AND FILTER
- METER
- FILTER
- DELIVERY HOSE
- NOZZLE
- NOZZLE HOLDER
- INSTRUCTION MANUAL

DETAILS



WATER CAPTOR FILTER (pag. 170)



MAN. / AUTOM. NOZZLE



K24 / K600 B/3 METER



K33 METER

DIMENSIONS

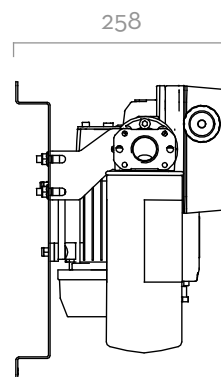
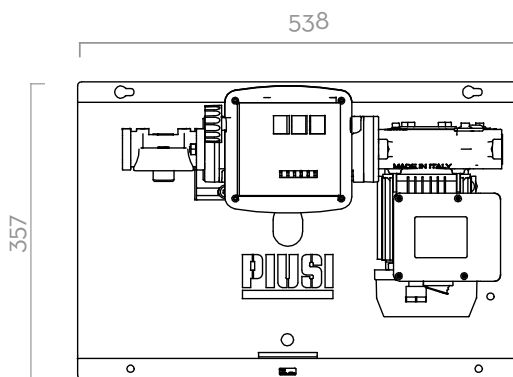

Dimensions expressed in millimeters

COMPONENTS

- **PUMPS:**
PANTHER AC PAG. 102
E80/E120 PAG. 106
- **NOZZLE:**
AUTOMATIC NOZZLE PAG. 158
- **METER:**
K33 PAG. 146
K24 PAG. 132
K600 B/3 PAG. 136
- **FILTER**
WATER CAPTOR PAG. 170

TECHNICAL DATA

CODE	DESCRIPTION	FLUIDS TYPE	FLOW RATE		VOLTAGE			METER	NOZZLE	FILTER	DELIVERY HOSE		SUCTION HOSE		INLET
			L/MIN	GPM	AC V/Hz	DC VOLT	POWER WATT				AMP. MAX.	LENGTH	Ø	LENGTH	
FO0386FOA	ST PANTHER 56 FILTER + A60	D	52	14	230/50	350	3	K33	A60	YES	6M	3/4"	4M	1"	
FO0265FOA	ST PANTHER 72 FILTER + A60	D	70	18	230/50	500	4,2	K33	A60	YES	6M	3/4"	4M	1"	
FO0395FOA	ST E120 FILTER + A120	D	85	22	230/50	1150	5,7	K33	A120	YES	6M	1"	4M	1"	
FO0386F60	ST PANTHER 56 FILTER + A60	D	52	14	230/50	350	3	K33	A60	YES	6M	3/4"	-	-	
FO0386R70	ST PANTHER 56 + CLEAR CAPTOR + A60	D	52	14	230/50	350	3	K33	A60	YES	6M	3/4"	-	-	
FO0265F40	ST PANTHER 72 FILTER + A60	D	70	18	230/50	500	4,2	K33	A60	YES	6M	3/4"	-	-	
FO0265S80	ST PANTHER 72 K600 B/F/6T/PA60	D	70	18	230/50	500	4,2	K600 B/3	A60	YES	6M	1"	-	-	
FO0395F60	ST E 120 FILTER + A120	D	85	22	230/50	1150	5,7	K33	A120	YES	6M	1"	-	-	
FO0265S20	ST PANTHER 72 FILTER + K24 METER	D	70	18	230/50	500	4,2	K24	A80	YES	6M	3/4"	-	-	
FO0265R70	ST PANTHER 72 + CLEAR CAPTOR + A80	D	70	18	230/50	500	4,2	K24	A80	YES	6M	1"	-	-	

ST WITH METER AND FILTER



FUEL MANAGEMENT SYSTEMS



DISPENSERS



KITS



PUMPS



METERS



NOZZLES

ST BOX

FEATURES

- STURDY STRUCTURE
- LOCKABLE AND SAFE
- READY TO USE
- FILTRATION GUARANTEED
- NOZZLE CONTACT (PRO VERSION ONLY)

The PIUSI ST BOX is a diesel refueling station complete with pump, flow meter and filter, with lockable metal protection box. The unit is complete with antistatic hose for diesel fuel and automatic dispensing nozzle. The Pro version features the electronic access control box ACCESS 85.

PERFORMANCE

UP TO

90 L/MIN

FLOW RATE

AC

CONTINUOUS DUTY

POWER

± 1%

ACCURACY



PACKAGING

CODE	WEIGHT		PACKAGING		
	KG	LBS	MM	INCH	PCS/BOX
WITHOUT ACCESS 85					
00036700B					
00036900B					
FO0365020					
FO0365060					
FO0365050	36	72	575X320X607	22,6X12,6X23,9	1
FO0365POA	40	88	575X320X607	22,6X12,6X23,9	1
FO039900A	50	110	590X340X720	23,2X13,4X28,3	1
WITH ACCESS 85					
FO0365010	40	88	575X320X607	22,6X12,6X23,9	1



FILTRATION



TANK MONITORING



HOSE REEL



ACCESSORIES



MERCHANDISE

INDEX



AIR



ANTIFREEZE



AdBlue®



BIODIESEL



DIESEL



FOOD



GASOLINE



GREASE



KEROSENE



OIL



WATER



WINDSCREEN

CHART

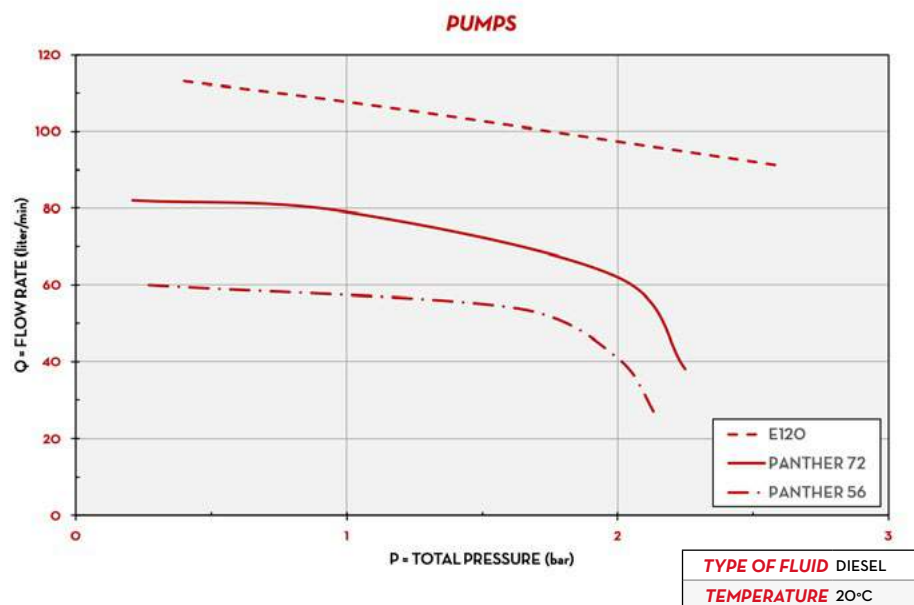

DIMENSIONS

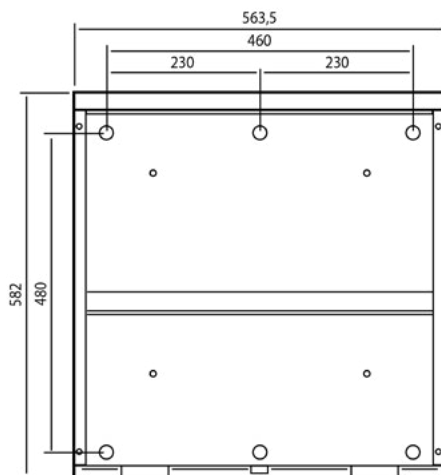

Dimensions expressed in millimeters

IN THE BOX

- ST BOX UNIT
- METER
- FILTER
- DELIVERY HOSE
- NOZZLE
- INSTRUCTION MANUAL

DETAILS



K33 MECH. METER (pag. 148)

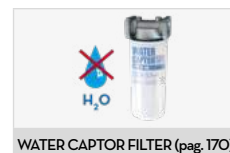

WATER CAPTOR FILTER (pag. 170)



DRIVER&MANAGER KEY



ACCESS 85 (pag. 194)

COMPONENTS

- **PUMPS:**
 PANTHER AC PAG. 102
 E80/E120 PAG. 106
 BIPUMP PAG. 116
- **NOZZLE:**
 AUTOMATIC NOZZLE PAG. 158
- **METER:**
 K33 PAG. 146
 K24 PAG. 132
- **FILTER**
 WATER CAPTOR PAG. 170
- **ACCESS CONTROL**
 ACCESS85 PAG. 194

TECHNICAL DATA

CODE	DESCRIPTION	FLUIDS TYPE	FLOW RATE		VOLTAGE			PUMP	METER	NOZZLE	FILTER	HOSE		INLET	
			L/MIN	GPM	AC V/HZ	DC VOLT	POWER WATT					AMP. MAX.	LENGTH		Ø
WITHOUT ACCESS 85															
00036700B	ST BOX E80/M K33 A80	D	80	21	230/50	500	3,5	E80	K33	A80	NO	4M	1"	1"	
00036900B	ST BOX E120/M K33 A120	D	90	22	230/50	750	5,7	E120	K33	A120	NO	4M	1"	1"	
FO0365020	ST BOX PANTHER 56 BASIC	D	56	15	230/50	350	3	PANTH. 56	K33	A60	YES	6M	1"	1"	
FO0365060	ST BOX PANTHER 72 BASIC	D	70	19	230/50	500	4,2	PANTH. 72	K33	A80	YES	6M	1"	1"	
FO0365050	ST BOX E 120 BASIC	D	90	22	230/50	750	5,7	E 120	K33	A120	YES	8M	1"	1"	
FO0365POA	ST BOX P56/M K33 A60	D	56	15	230/50	350	3	PANTH. 56	K33	A60	NO	4M	3/4"	1"	
FO039900A	ST BOX BIPUMP 12V K33 A120	D	80	21	12	530	44	BIPUMP	K33	A80	NO	4M	1"	1"	
WITH ACCESS 85															
FO0365010	ST BOX PANTHER 72 PRO	D	70	19	230/50	500	4,2	PANTH. 72	A80	AUT.	YES	6M	1"	1"	

PRO VERSION ONLY

ST BOX



FUEL MANAGEMENT SYSTEMS



DISPENSERS



KITS



PUMPS



METERS



NOZZLES

ST 200 AC

FEATURES

- STURDY METALLIC FRAME
- READY TO USE
- EASY TO MOVE
- HEAVY DUTY

The PIUSI ST 200 AC is a dispenser that allows high flow refueling thanks to the two integrated E120 self-priming rotary electric vane pumps. Fitted with by-pass valve and elevated reliability seal, the dispenser works even at low working temperatures and in every condition on worksites. The oval gear mechanical flow meter guarantees great precision (available on request). It is also available with wheels and handle (on request) for easier handling.

PERFORMANCE

UP TO
200 L/MIN

FLOW RATE

AC
CONTINUOUS DUTY

POWER



ST 200 AC



HANDY KIT: VERSION WITH WHEELS AND HANDLE

PACKAGING

CODE	WEIGHT		PACKAGING		
	KG	LBS	MM	INCH	PCS/BOX
FO0315000	46	101	587X395X420	23,1X15,6X16,5	1
F16860000	-	-	-	-	-



FILTRATION



TANK MONITORING



HOSE REEL



ACCESSORIES



MERCHANDISE

INDEX



AIR



ANTIFREEZE



AdBlue®



BIODIESEL



DIESEL



FOOD



GASOLINE



GREASE



KEROSENE



OIL



WATER



WINDSCREEN

CHART

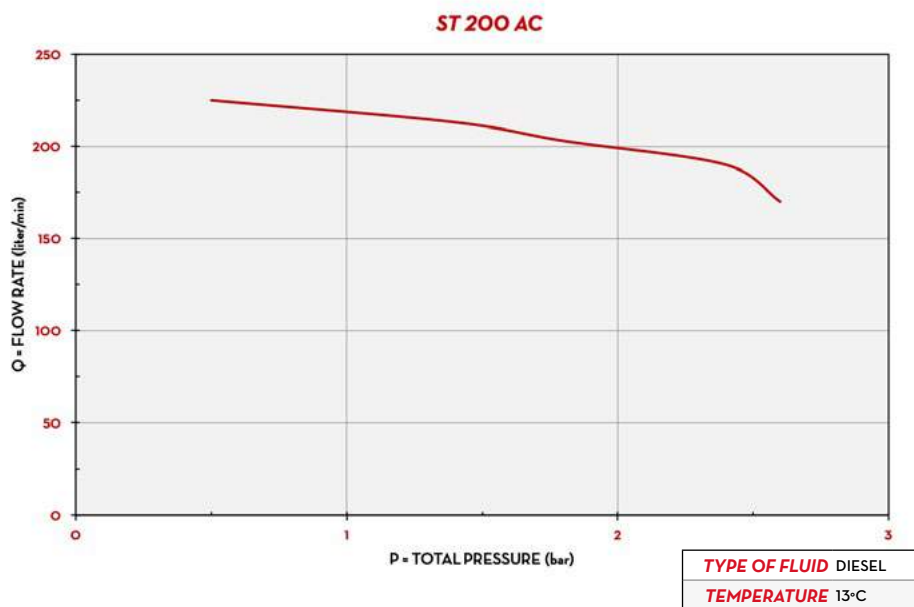

IN THE BOX

- ST 200 AC UNIT
- INSTRUCTION MANUAL

DETAILS



ON/OFF SWITCH

DIMENSIONS

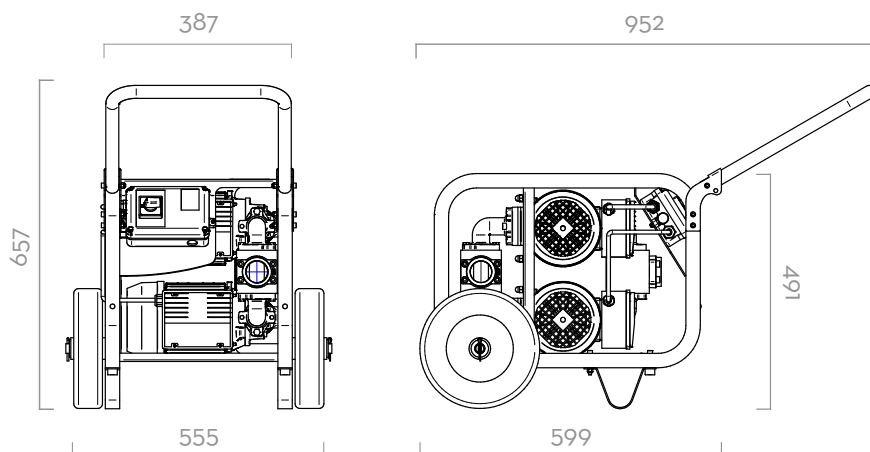

Dimensions expressed in millimeters

MATERIALS

- BODY: CAST IRON
- ROTOR: SINTERED STEEL
- VANES: ACETAL RESIN
- SEAL: VITON
- SHAFT: STEEL

TECHNICAL DATA

CODE	DESCRIPTION	FLUIDS TYPE	FLOW RATE		VOLTAGE			PUMP		MAX PRESSURE	OUTLET
			L/MIN	GPM	AC V/HZ DC VOLT	POWER WATT	AMP. MAX.	TYPE	N°	BAR	BSP
FO0315000	ST 200 BASIC	D	200	52,7	230/50	2050	10	E 120	2	2,5	1" 1/2
F16860000	HANDY KIT (HANDLE + WHEELS)	D	-	-	-	-	-	-	-	-	-

ST200 AC



FUEL MANAGEMENT SYSTEMS



DISPENSERS



KITS



PUMPS



METERS



NOZZLES

ST 200 DC

FEATURES

- STURDY STRUCTURE
- COMPACT DESIGN
- READY TO USE
- HIGH RELIABILITY
- HEAVY DUTY

PIUSI ST 200 DC is a 24V portable dispensing unit for high flow applications. The low weight of the unit makes it easy to handle and suitable for operating on worksites in every condition; both on tanks or for mobile applications. Thanks to the mechanical meter K700, this sturdy dispenser guarantees the maximum precision (on request).

PERFORMANCE

UP TO
185 L/MIN

FLOW RATE

24V
VOLTAGE

POWER

20 MIN
(40MIN OFF)

DUTY CICLE



ST 200 DC



PACKAGING

CODE	WEIGHT		PACKAGING		
	KG	LBS	MM	INCH	PCS/BOX
FO0318000	18	40	480X370X265	18,9X14,6X10,4	1



FILTRATION



TANK MONITORING



HOSE REEL



ACCESSORIES



MERCHANDISE

INDEX



AIR



ANTIFREEZE



AdBlue®



BIODIESEL



DIESEL



FOOD



GASOLINE



GREASE



KEROSENE



OIL



WATER



WINDSCREEN

CHART

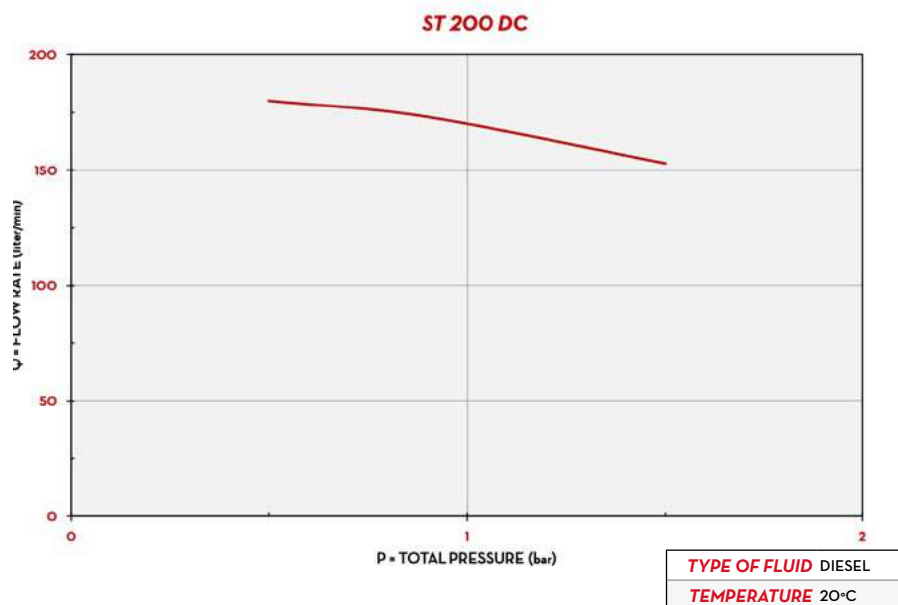

IN THE BOX

- ST 200 DC UNIT
- ELECTRIC CABLE WITH CLAMPS
- INSTRUCTION MANUAL

DETAILS



ON/OFF SWITCH



ELECTRIC CABLE WITH CLAMPS

DIMENSIONS

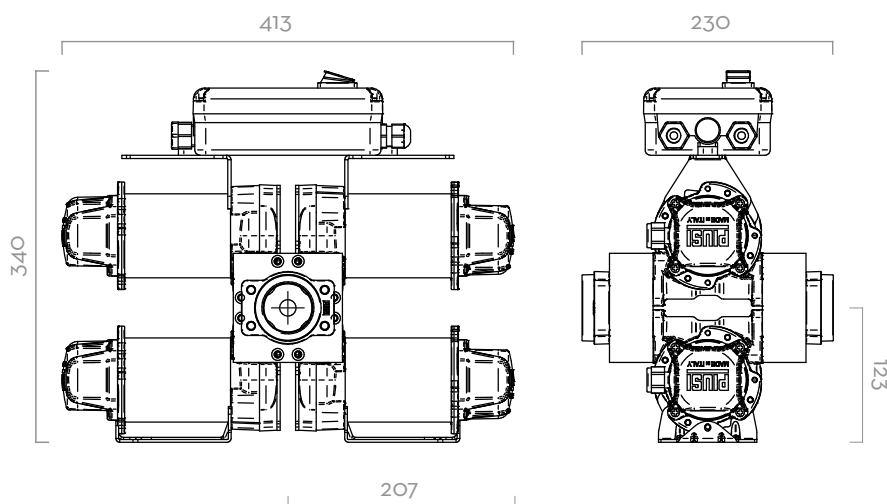

Dimensions expressed in millimeters

MATERIALS

- BODY: CAST IRON
- ROTOR: SINTERED STEEL
- VANES: ACETAL RESIN
- SEAL: NBR
- SHAFT: STEEL

TECHNICAL DATA



CODE	DESCRIPTION	FLUIDS TYPE	FLOW RATE		VOLTAGE			DUTY CICLE	PUMP		MAX PRESSURE	OUTLET
			L/MIN	GPM	AC V/HZ	DC VOLT	POWER WATT		AMP. MAX.	MINUTES		
FO0318000	ST 200 DC 24 V	D	185	42-48	24	1200	50	30	BYPASS 3000	4	2	1" 1/2

ST200 DC





KITS ACCESSORIES

ATEX

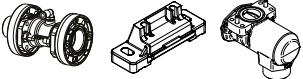

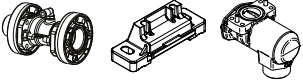
EX50 DRUM	CODE	DESCRIPTION	
	F1815600B	(EX) ADAPTER FOR CONDUIT EX50	
	F1862600A	(EX)CABLE+CABLEGLAND ECEX EX50 12V	
	F1862400C	(EX) CABLE GLAND EXD-NPT IECEX	



EX100 DRUM	CODE	DESCRIPTION	
	F21770000	BUNG ADAPTER 2" BSP COMPLETE	
	F22436010	ANTISIPHON KIT FOR EX100/EX140/E140 BSP	
	F22053000	MOTOR SUPPORT FEET EX80/100/140	

EX140 DRUM	CODE	DESCRIPTION	
	F21770000	BUNG ADAPTER 2" BSP COMPLETE	
	F22436010	ANTISIPHON KIT FOR EX100/EX140/E140 BSP	
	F22053000	MOTOR SUPPORT FEET EX80/100/140	

EX50 ST	CODE	DESCRIPTION	
	F1815600B	(EX) ADAPTER FOR CONDUIT EX50	
	F1862600A	(EX)CABLE+CABLEGLAND ECEX EX50 12V	
	F1862400C	(EX) CABLE GLAND EXD-NPT IECEX	



MOBILE

BATTERY KIT	CODE	DESCRIPTION	
	F16586000	DRUM 3000 KIT	
	F16631000	KIT DRUM 3000 K33 / FILTER / ADAPTER	

PIUSIBOX	CODE	DESCRIPTION	
	F16483010	CARTRIDGE 10 MICRON 3/4IN PIUSI BOX 15PC	
	R20764000	K24 ASSEMBLY KIT FOR PIUSIBOX N.	



ST

ST BOX	CODE	DESCRIPTION
	F1249600A	MANAGER KEY 2018
	F1590400A	KIT DRIVER KEY YELLOW (10PCS)
	F17121000	LEVEL PROBE FOR ACCESS 85
	F1721800A	ST BOX NEW







F17121000
F1249600A
F1590400A

ST 200 AC	CODE	DESCRIPTION
	F16860000	KIT WHEELS \ HANDLE ST200
	F18798000	KIT HOSE 1 1/2" 10 MT+CAMLOCK+HOSETAIL
	F18799000	KIT HOSE 1 1/2" 20 MT+CAMLOCK+HOSETAIL

F18798000
F18799000
F16860000

ST 200 DC	CODE	DESCRIPTION
	F18798000	KIT HOSE 1 1/2" 10 MT+CAMLOCK+HOSETAIL
	F18799000	KIT HOSE 1 1/2" 20 MT+CAMLOCK+HOSETAIL

F18798000
F18799000





PUMPS



FUEL MANAGEMENT SYSTEMS



DISPENSERS



KITS



PUMPS



METERS



NOZZLES

EX50 AC

FEATURES

- COMPACT AND STURDY DESIGN
- FLANGED COMPONENTS
- ANTI-NOISE FILTER
- THERMAL PROTECTION
- SUCTION UNIT WITH INTEGRATED FILTER (DRUM VERSION)
- UL VERSION AVAILABLE

The PIUSI EX50 AC is a compact and sturdy pump that satisfies the strictest ATEX/IECEx requirements concerning the usage of this equipment in potentially explo-sive atmospheres. It is equipped with built-in bypass valve, non-return valve and anti-noise filter.

PERFORMANCE

UP TO
50 L/MIN

FLOW RATE

AC
VOLTAGE
POWER

30 MIN
(30MIN OFF)
DUTY CICLE

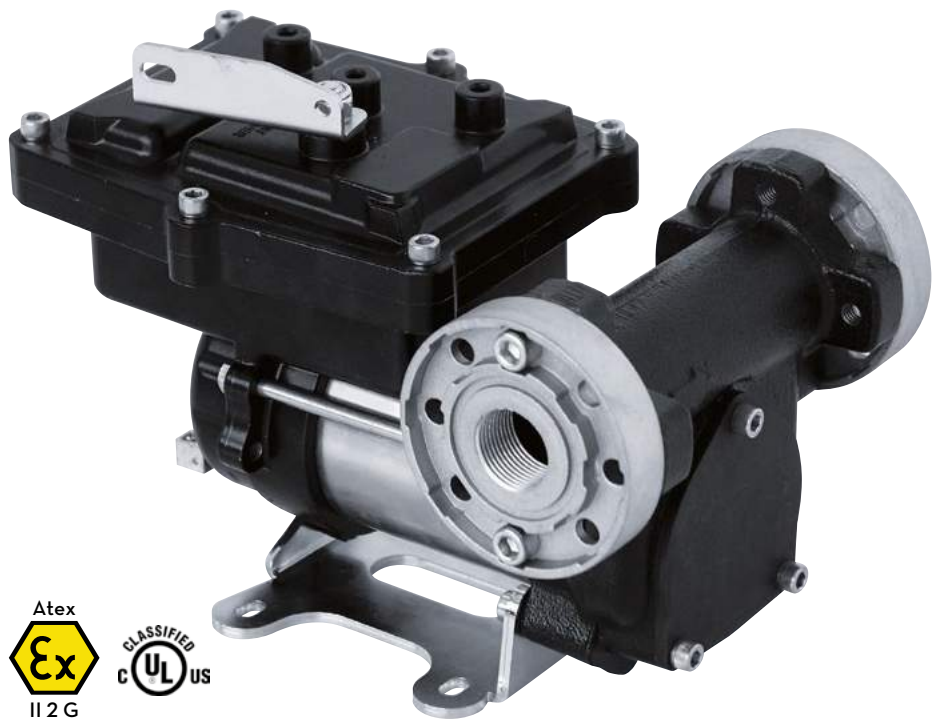



EX50 PUMP



OUR PUMPS COMPLIES WITH THE FOLLOWING MARKING ATEX/IECEx

II	2	G	Ex	d	db	IIA	IIB	T4	Gb
GROUP	CATEGORY	TYPE OF EXPLOSIVE ATMOSPHERE	PERMANENT PREFIX	PROTECTION METHOD		GAS GLASS		TEMPERATURE CLASS	EQUIPMENT PROTECTION LEVEL
				EX50	EX75	EX50	EX75		

PACKAGING

CODE	WEIGHT		PACKAGING			N. BOXES / EUROPALET	
	KG	LBS	MM	INCH	PCS/BOX		
FO037300A	6,9	15,2	345X175X225	-	1	60	84



FILTRATION



TANK MONITORING



HOSE REEL



ACCESSORIES



MERCHANDISE

INDEX



AIR



ANTIFREEZE



AdBlue®



BIODIESEL



DIESEL



FOOD



GASOLINE



GREASE



KEROSENE



OIL



WATER



WINDSCREEN

CHART

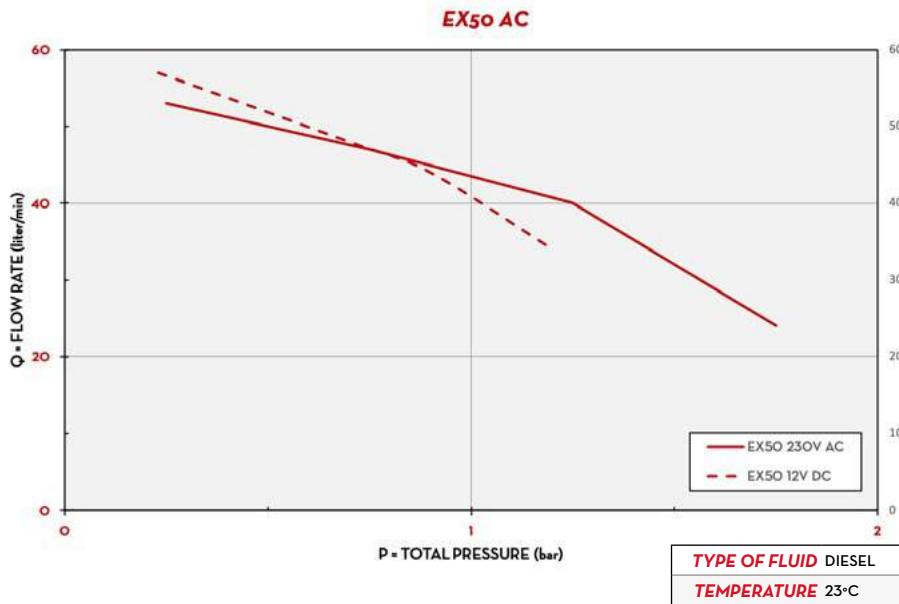

IN THE BOX

- EX50 AC PUMP
- FLANGED CONNECTIONS
- INSTRUCTION MANUAL

DETAILS



ON/OFF SWITCH



FLANGED CONNECTIONS

DIMENSIONS

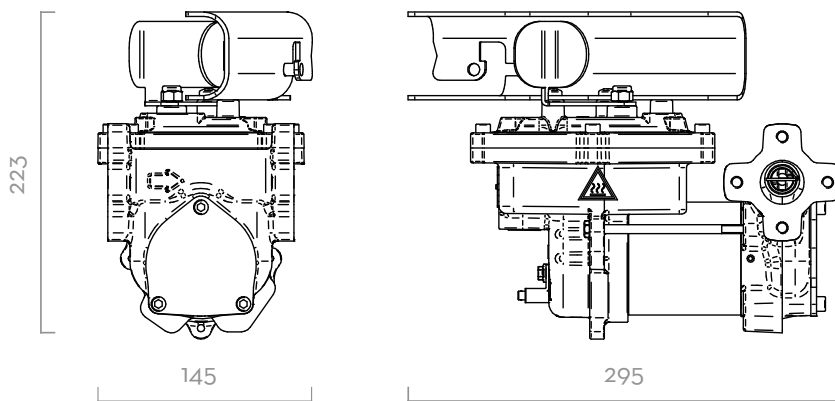

Dimensions expressed in millimeters

MATERIALS

- BODY: CAST IRON
- ROTOR: SINTERED STEEL
- VANES: PPS
- SEAL: VITON
- SHAFT: STEEL



PUMP

- > MAX 6M (20FT),
- > SUCTION HOSE Ø 1" MIN,
- > MAX SUCTION HEIGHT:
 - 2M (7FT) W/O NON RETURN VALVE
 - 4M (14FT) W NON RETURN VALVE



TANK

TECHNICAL DATA

CODE	DESCRIPTION	FLUIDS TYPE	FLOW RATE		VOLTAGE			DUTY CICLE		RPM	OUTLET
			L/MIN	GPM	AC VOLT/Hz	POWER WATT	AMP. MAX.	MINUTES			
FO037300A	EX50 230V AC ATEX	D G K	50	13	230/50-60	250	1,2	30	2700	1"	

() UPON REQUEST IT IS AVAILABLE WITH DIFFERENT VOLTAGES AND 60 HZ FREQUENCY. THE PUMP CAN BE USED ONLY WITH THE FOLLOWING FLUIDS: DIESEL, KEROSENE, PETROL, PETROL ALCOHOL MIXED MAX 15%, AVGAS 100/100LL, JET A/A1 - ASPEN 2/4

EX50 AC



FUEL MANAGEMENT SYSTEMS



DISPENSERS



KITS



PUMPS



METERS



NOZZLES

EX100

FEATURES

- HIGH FLOW RATE
- HEAVY DUTY
- CONTINUOUS DUTY
- THERMAL PROTECTION
- UL VERSION AVAILABLE
- REMOVABLE PUMP FEET

PIUSI EX100 is the new pump of the EX line, suitable for the transfer of gasoline and diesel with high performance and continuous duty. The directive on the use of materials in potentially explosive atmospheres is very precise, as confirmed by the ATEX certification. Simple to use, compact, versatile, it performs high flow rate and continuous duty cycle.

PERFORMANCE

UP TO
100 L/MIN

FLOW RATE

AC
VOLTAGE

POWER



EX100

OUR PUMPS COMPLIES WITH THE FOLLOWING MARKING ATEX/IECEX

II	2	G	Ex	d	IIA	T4	Gb
GROUP	CATEGORY	TYPE OF EXPLOSIVE ATMOSPHERE	PERMANENT PREFIX	PROTECTION METHOD	GAS GLASS	TEMPERATURE CLASS	EQUIPMENT PROTECTION LEVEL

PACKAGING

CODE	WEIGHT		PACKAGING		
	KG	LBS	MM	INCH	PCS/BOX
FO0390010	25	55	240X400X350	9,4X15,7X13,8	1
FO0390020	25	55	240X400X350	9,4X15,7X13,8	1



FILTRATION



TANK MONITORING



HOSE REEL



ACCESSORIES



MERCHANDISE

INDEX



AIR



ANTIFREEZE



AdBlue®



BIODIESEL



DIESEL



FOOD



GASOLINE



GREASE



KEROSENE



OIL



WATER



WINDSCREEN

CHART

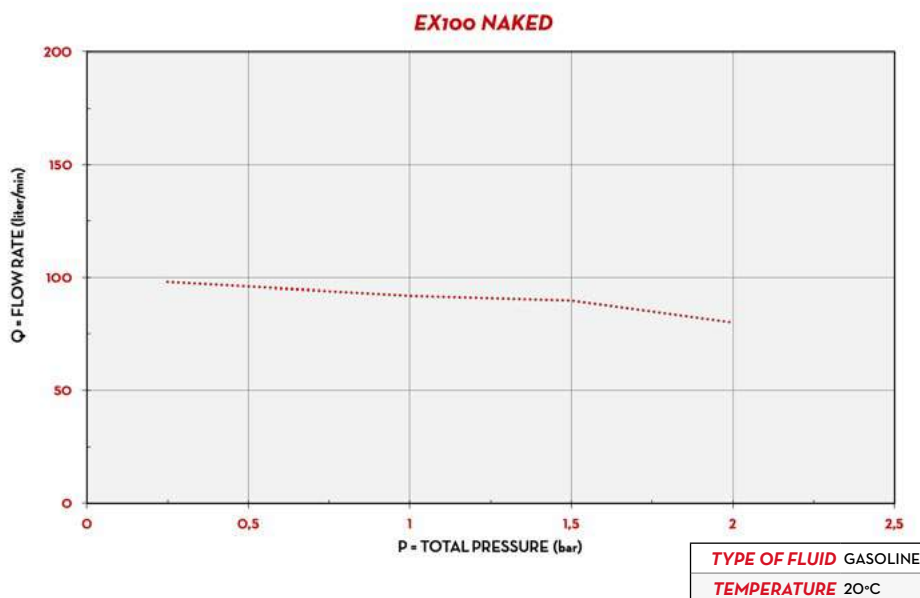

DIMENSIONS

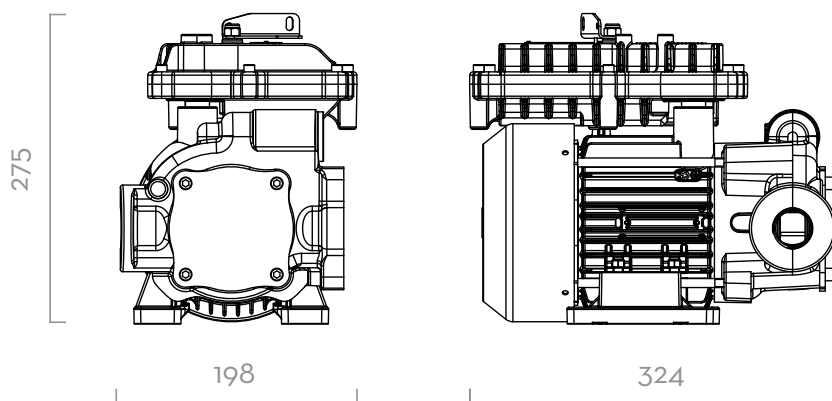

Dimensions expressed in millimeters

IN THE BOX

- EX100 PUMP
- PUMP FEET
- INSTRUCTION MANUAL

DETAILS



ON/OFF SWITCH



VANE ROTOR



BYPASS VALVE

MATERIALS

- BODY: CAST IRON
- ROTOR: SINTERED STEEL
- VANES: TECHNOPYLIMER
- SEAL: VITON
- SHAFT: STEEL



PUMP

- > MAX 6M (20FT),
- > SUCTION HOSE Ø 1" MIN,
- > MAX SUCTION HEIGHT:
- 2M (7FT) W/O NON RETURN VALVE
- 4M (14FT) W NON RETURN VALVE



TANK

TECHNICAL DATA

CODE	DESCRIPTION	FLUIDS TYPE	FLOW RATE		VOLTAGE			DUTY CICLE	RPM	INLET		OUTLET	
			L/MIN	GPM	AC VOLT/HZ	POWER WATT	AMP. MAX.			CONTINUOUS	BSP	BSP	
FO0390010	EX 100 230/50	D G K	100	25	230/50	1035	4,5	YES	1450	1" 1/4	1"		
FO0390020	EX 100 230/60	D G K	100	25	230/60	874	3,8	YES	1750	1" 1/4	1"		

() UPON REQUEST IT IS AVAILABLE WITH DIFFERENT VOLTAGES AND 60 HZ FREQUENCY. THE PUMP CAN BE USED ONLY WITH THE FOLLOWING FLUIDS: DIESEL, KEROSENE, PETROL, PETROL ALCOHOL MIXED MAX 15%, AVGAS 100/100LL, JET A/A1 - ASPEN 2/4

EX100



FUEL MANAGEMENT SYSTEMS



DISPENSERS



KITS



PUMPS



METERS



NOZZLES

EX140



FEATURES

- HIGH FLOW RATE
- HEAVY DUTY
- CONTINUOUS DUTY
- THERMAL PROTECTION
- UL VERSION AVAILABLE
- REMOVABLE PUMP FEET

The entirely new EX line is characterized by a high flow rate that works with a continuous duty cycle, and has been designed to be particularly suitable for Heavy Duty, i.e. for those demanding fleets that need to dispense fuels such as Gasoline, diesel or kerosene quickly.

PERFORMANCE

UP TO
140 L/MIN

FLOW RATE

AC
VOLTAGE
POWER



EX140

OUR PUMPS COMPLIES WITH THE FOLLOWING MARKING ATEX/IECEX

II	2	G	Ex	d	IIA	T4	Gb
GROUP	CATEGORY	TYPE OF EXPLOSIVE ATMOSPHERE	PERMANENT PREFIX	PROTECTION METHOD	GAS GLASS	TEMPERATURE CLASS	EQUIPMENT PROTECTION LEVEL

PACKAGING

CODE	WEIGHT		PACKAGING		
	KG	LBS	MM	INCH	PCS/BOX
FO0395010	25	55	240X400X350	9,4X15,7X13,8	1
FO0395020	25	55	240X400X350	9,4X15,7X13,8	1
FO0395030	25	55	240X400X350	9,4X15,7X13,8	1



FILTRATION



TANK MONITORING



HOSE REEL



ACCESSORIES



MERCHANDISE

INDEX



AIR



ANTIFREEZE



AdBlue®



BIODIESEL



DIESEL



FOOD



GASOLINE



GREASE



KEROSENE



OIL



WATER



WINDSCREEN

CHART

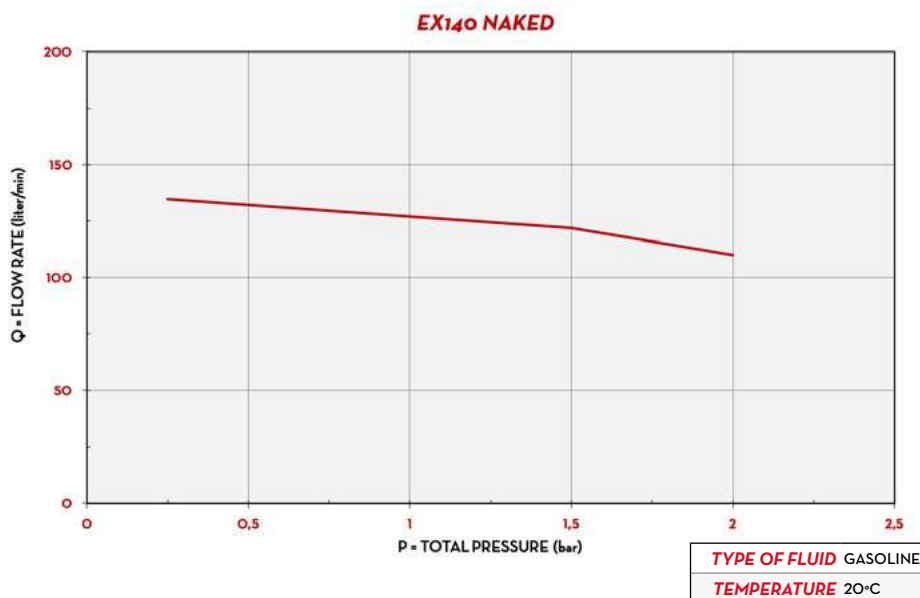

DIMENSIONS

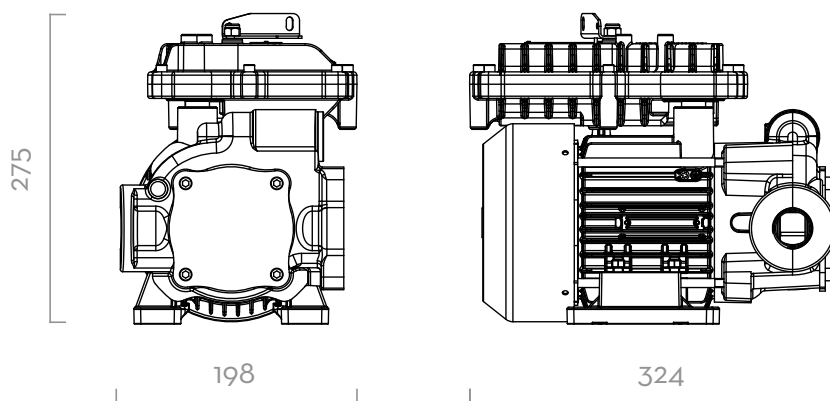

Dimensions expressed in millimeters

IN THE BOX

- EX140 PUMP
- PUMP FEET
- INSTRUCTION MANUAL

DETAILS



MATERIALS

- BODY: CAST IRON
- ROTOR: SINTERED STEEL
- VANES: TECHNOPOLYMER
- SEAL: VITON
- SHAFT: STEEL



PUMP

- > MAX 6M (20FT),
- > SUCTION HOSE Ø 1" MIN,
- > MAX SUCTION HEIGHT:
 - 2M (7FT) W/O NON RETURN VALVE
 - 4M (14FT) W NON RETURN VALVE



TANK

TECHNICAL DATA

CODE	DESCRIPTION	FLUIDS TYPE	FLOW RATE		VOLTAGE			DUTY CICLE	RPM	INLET		OUTLET
			L/MIN	GPM	AC VOLT/HZ	POWER WATT	AMP. MAX.			CONTINUOUS	BSP	BSP
FO0395010	EX 140 230/50	D G K	140	37	230/50	1150	5	YES	1450	1" 1/4	1"	
FO0395020	EX 140 250/50	D G K	140	37	250/50	1125	4,5	YES	1450	1" 1/4	1"	
FO0395030	EX 140 230/60	D G K	140	37	230/60	920	4	YES	1750	1" 1/4	1"	

() UPON REQUEST IT IS AVAILABLE WITH DIFFERENT VOLTAGES AND 60 HZ FREQUENCY. THE PUMP CAN BE USED ONLY WITH THE FOLLOWING FLUIDS: DIESEL, KEROSENE, PETROL, PETROL ALCOHOL MIXED MAX 15%, AVGAS 100/100LL, JET A/A1 - ASPEN 2/4

EX140



FUEL MANAGEMENT SYSTEMS



DISPENSERS



KITS



PUMPS



METERS



NOZZLES

EX50 / EX75 DC

FEATURES

- COMPACT AND STURDY DESIGN
- FLANGED COMPONENTS
- ANTI-NOISE FILTER
- THERMAL PROTECTION
- SUCTION UNIT WITH INTEGRATED FILTER (DRUM VERSION)
- UL LISTED MOTOR AVAILABLE

The PIUSI EX50/EX75 DC is a transfer pump suitable for flammable fuels such as petrol, kerosene and diesel. It is fully compliant with ATEX/IECEX requirements for the usage in potentially explosive atmospheres. Designed to transfer flammable fluids from tanks of any type, this pump is available in DC version and is fitted with a bypass valve and can dispense up to 75 l/min, with reduced absorption to ensure a long life to the pump.

PERFORMANCE

UP TO

75 L/MIN

FLOW RATE

12V

VOLTAGE

POWER

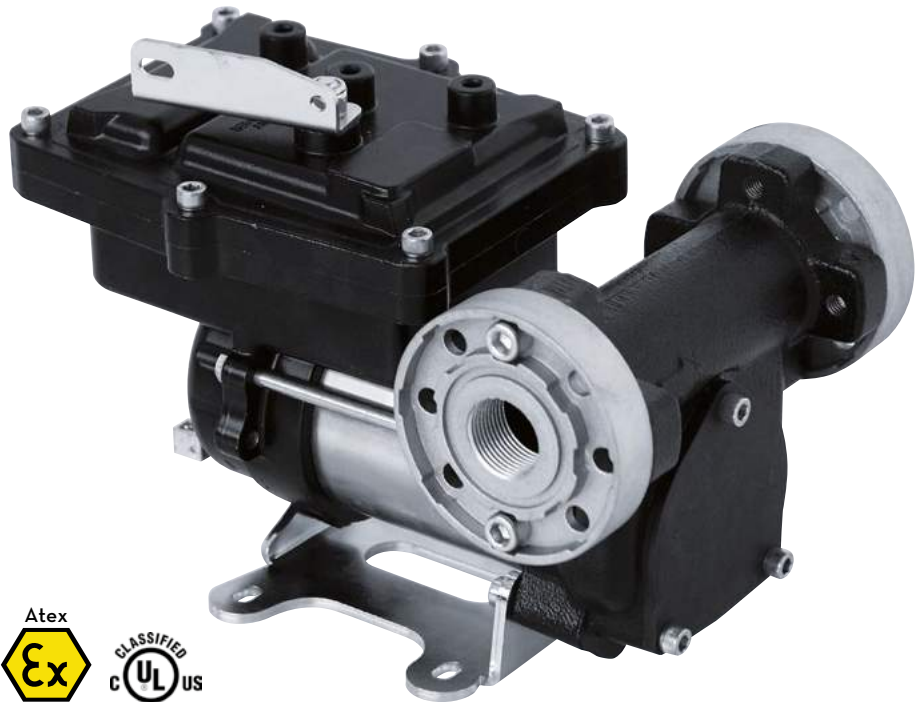



EX75 DC



OUR PUMPS COMPLIES WITH THE FOLLOWING MARKING ATEX/IECEX

II	2	G	Ex	d	db	IIA	IIB	T4	Gb
GROUP	CATEGORY	TYPE OF EXPLOSIVE ATMOSPHERE	PERMANENT PREFIX	PROTECTION METHOD		GAS GLASS		TEMPERATURE CLASS	EQUIPMENT PROTECTION LEVEL
				EX50	EX75	EX50	EX75		

PACKAGING

CODE	WEIGHT		PACKAGING			N. BOXES / EUROPALLET	
	KG	LBS	MM	INCH	PCS/BOX		
FO0371000	6,9	15,2	345X175X225	-	1	60	84
FO0380000	8	17,8	350X185X260	-	1	60	84



FILTRATION



TANK MONITORING



HOSE REEL



ACCESSORIES



MERCHANDISE

INDEX



AIR



ANTIFREEZE



AdBlue®



BIODIESEL



DIESEL



FOOD



GASOLINE



GREASE



KEROSENE



OIL



WATER



WINDSCREEN

CHART

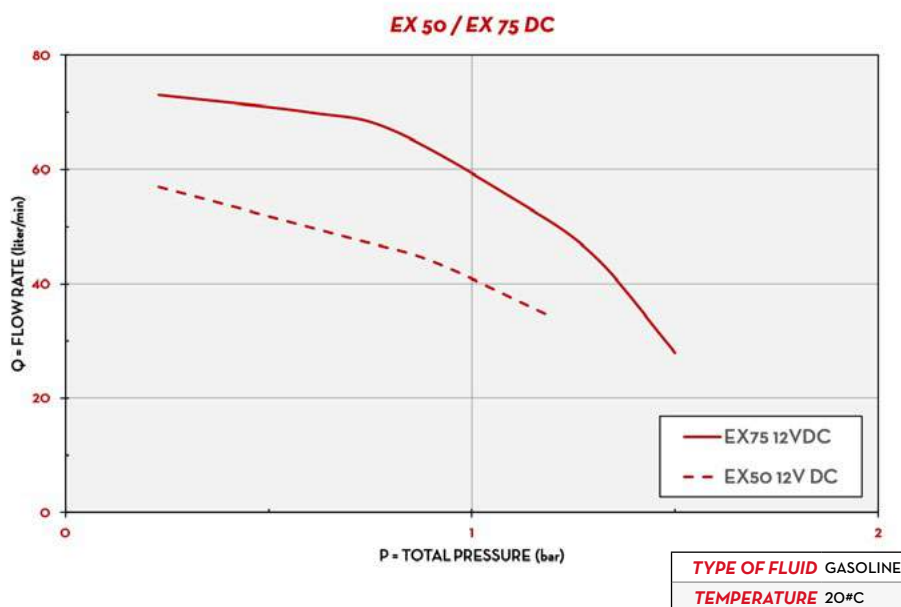

IN THE BOX

- EX50 / EX75 DC PUMP
- FLANGED CONNECTIONS
- INSTRUCTION MANUAL

DETAILS



ON/OFF SWITCH



FLANGED CONNECTIONS

DIMENSIONS

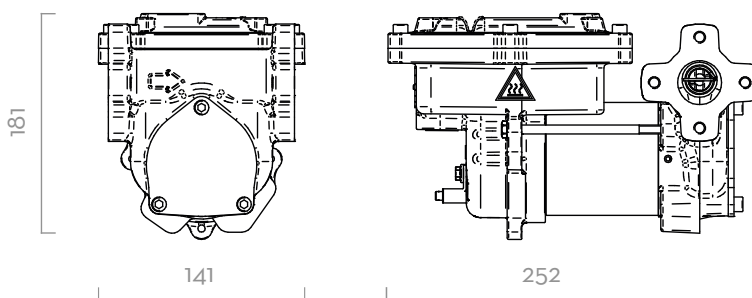

Dimensions expressed in millimeters

MATERIALS

- BODY: CAST IRON
- ROTOR: SINTERED STEEL
- VANES: PPS
- SEAL: VITON
- SHAFT: STEEL



PUMP

- > MAX 6M (20FT),
- > SUCTION HOSE Ø 1" MIN,
- > MAX SUCTION HEIGHT:
 - 2M (7FT) W/O NON RETURN VALVE
 - 4M (14FT) W NON RETURN VALVE



TANK

TECHNICAL DATA

CODE	DESCRIPTION	FLUIDS TYPE	FLOW RATE		VOLTAGE			DUTY CYCLE		RPM	OUTLET BSP
			L/MIN	GPM	AC VOLT/HZ	POWER WATT	AMP. MAX.	MINUTES			
FO0371000	EX50 12V DC ATEX	D G K	50	13	12	250	21	30	2700	1"	
FO0380000	EX75 12V DC ATEX	D G K	75	19,8	12	240	20	30	2700	1"	

() UPON REQUEST IT IS AVAILABLE WITH DIFFERENT VOLTAGES AND 60 HZ FREQUENCY. THE PUMP CAN BE USED ONLY WITH THE FOLLOWING FLUIDS: DIESEL, KEROSENE, PETROL, PETROL ALCOHOL MIXED MAX 15%, AVGAS 100/100LL, JET A/A1 - ASPEN 2/4

EX50 / EX75 DC



FUEL MANAGEMENT SYSTEMS



DISPENSERS



KITS



PUMPS



METERS



NOZZLES

PANTHER AC

FEATURES

- COMPACT AND STURDY DESIGN
- READY TO USE
- EASY TO INSTALL
- INTEGRATED FILTER

The PIUSI PANTHER AC is a versatile self-priming rotary electric vane transfer pump available in three versions (56 - 72 - 90) particularly suitable for dispensers, fixed fuel transferring system and other industrial applications. It is equipped with a by-pass valve and an incorporated filter to stop impurities.

PERFORMANCE

UP TO
90 L/MIN

FLOW RATE

AC
CONTINUOUS DUTY

POWER



PANTHER 56 (flanges not included)



PANTHER 72 - PANTHER 90 (flanges included)

PACKAGING

CODE	WEIGHT		PACKAGING			N. BOXES / EUROPALLET	
	KG	LBS	MM	INCH	PCS/BOX	✈	🚛
PANTHER 56							
FO0730000	7,4	16,3	345X175X255	-	1	60	84
000731000	7,4	16,3	345X175X255	-	1	60	84
000733000	7,4	16,3	345X175X255	-	1	60	84
PANTHER 72							
000732000	7,9	17,4	345X175X255	-	1	60	84
000735000	7,9	17,4	345X175X255	-	1	60	84
PANTHER 90							
FO0733020	8,2	19,9	345X175X255	-	1	60	84



FILTRATION



TANK MONITORING



HOSE REEL



ACCESSORIES



MERCHANDISE

INDEX



AIR



ANTIFREEZE



AdBlue®



BIODIESEL



DIESEL



FOOD



GASOLINE



GREASE



KEROSENE



OIL



WATER



WINDSCREEN

CHART

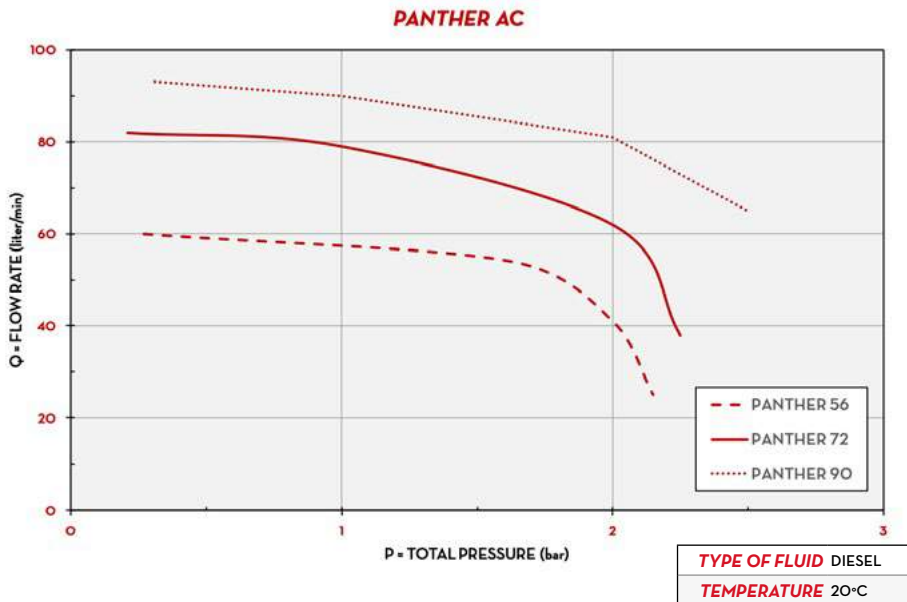

IN THE BOX

- PANTHER AC PUMP
- INSTRUCTION MANUAL

DETAILS



DIMENSIONS

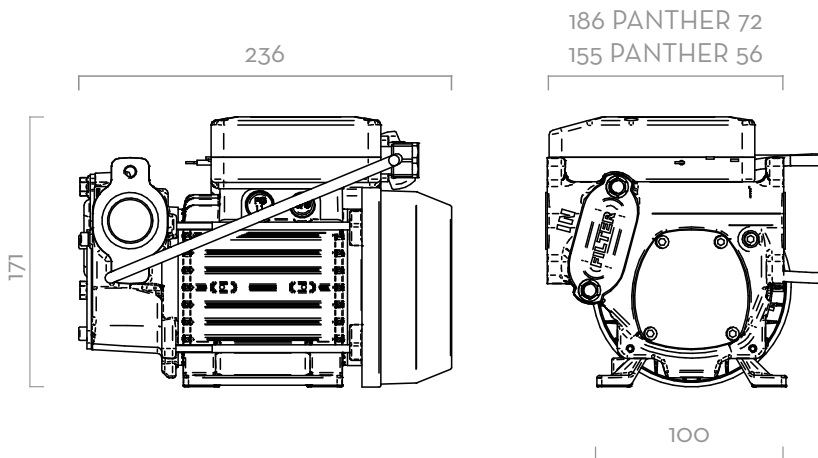

Dimensions expressed in millimeters

MATERIALS

- BODY: CAST IRON
- ROTOR: SINTERED STEEL
- VANES: TECHNOPYLIMER
- SHAFT: STEEL



PUMP

- MAX 6M (20FT),
- SUCTION HOSE Ø 1" MIN,
- MAX SUCTION HEIGHT:
- 2M (7FT) W/O NON RETURN VALVE
- 4M (14FT) W NON RETURN VALVE



TANK

TECHNICAL DATA

CODE	DESCRIPTION	FLUIDS TYPE	FLOW RATE		VOLTAGE				RPM	INLET OUTLET		FLANGE CONNECTION	BYPASS VALVE	INLET FILTER
			L/MIN	GPM	SINGLEPHASE MOTOR V/HZ	THREEPHASE MOTOR V/HZ	POWER WATT	AMP. MAX.		BSP				
PANTHER 56														
FO0730000	PANTHER 56 230/50	D	56	15	230/50	-	350	3	2900	1"	-	-	YES	YES
000731000	PANTHER 56 230/60	D	68	18	230/60	-	500	3,9	3400	1"	-	-	YES	YES
000733000	PANTHER 56 400/50	D	56	15	-	400/50	500	1,3	2900	1"	-	-	YES	YES
PANTHER 72														
000732000	PANTHER 72 230/50	D	72	19	230/50	-	500	4,2	2900	1"	YES	YES	YES	YES
000735000	PANTHER 72 400/50	D	72	19	-	400/50	500	1,6	2900	1"	YES	YES	YES	YES
PANTHER 90														
FO073302A	PANTHER 90 230/50	D	90	23,8	230/50	-	700	4,9	2900	1"	YES	YES	YES	YES

UPON REQUEST IT IS AVAILABLE WITH DIFFERENT VOLTAGES AND 60 HZ FREQUENCY.
() EXCEPT PANTHER 90

PANTHER AC



FUEL MANAGEMENT SYSTEMS



DISPENSERS



KITS



PUMPS



METERS



NOZZLES

VISCOMAT VANE

FEATURES

- VERSATILITY
- MOBILE AND READY TO USE
- MULTIPURPOSE PUMP
- ADJUSTABLE BYPASS

The PIUSI VISCOMAT VANE is an electric vane pump suitable for all those applications where it is necessary to apply a transfer system with high suction capacity in order to transfer fluids with low viscosity up to 500 cSt. The pump is fitted with an asynchronous and self-ventilating motor, closed and available in different voltages and frequencies in order to adapt to any working condition.

PERFORMANCE

UP TO
50 L/MIN

FLOW RATE

AC
CONTINUOUS DUTY

POWER

UP TO
500 CST

VISCOSITY



VISCOMAT VANE



PACKAGING

CODE	WEIGHT		PACKAGING			N. BOXES / EUROPALLET	
	KG	LBS	MM	INCH	PCS/BOX	✈	🚚
VISCOMAT 70							
FO033490A	14,1	31,1	355X185X285	-	1	60	72
FO033190A	14,1	31,1	350X200X280	-	1	60	72
VISCOMAT 90							
FO0303M00	14,1	31,1	350X200X280	-	1	60	72
000303000	14,1	31,1	350X200X280	-	1	60	72



FILTRATION



TANK MONITORING



HOSE REEL



ACCESSORIES



MERCHANDISE

INDEX



AIR



ANTIFREEZE



AdBlue®



BIODIESEL



DIESEL



FOOD



GASOLINE



GREASE



KEROSENE



OIL



WATER



WINDSCREEN

CHART

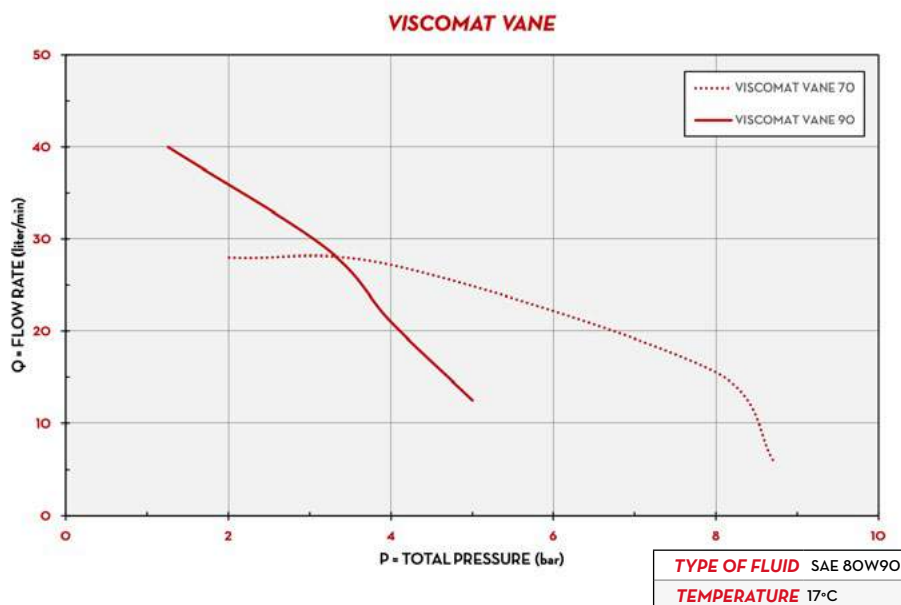

DIMENSIONS

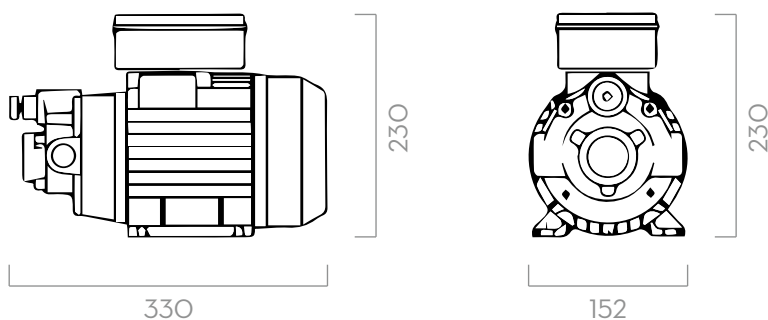

Dimensions expressed in millimeters

IN THE BOX

- VISCOMAT VANE PUMP
- INSTRUCTION MANUAL

DETAILS

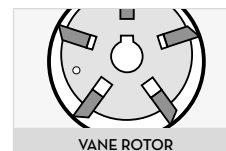

MATERIALS

- BODY: CAST IRON
- ROTOR: SINTERED STEEL
- VANES: TECHNOPOLYMER
- SHAFT: STEEL



- > SUCTION HOSE Ø 1" MIN,
- > MAX SUCTION HEIGHT:
 - 2M (7FT) W/O NO BACK VALVE
 - 4M (14FT) W NO BACK VALVE



TECHNICAL DATA

CODE	DESCRIPTION	FLUIDS TYPE	FLOW RATE		PRESSURE		VOLTAGE				RPM	INLET OUTLET		ADJUSTABLE BYPASS VALVE
			L/MIN	GPM	BAR	PSI	SINGLEPHASE MOTOR V/Hz	THREEPHASE MOTOR V/Hz	POWER WATT	AMP. MAX.		BSP		
VISCOMAT 70														
FO033490A	VISCOMAT 70 M 230/50-60	D O B	25	7	6	85	230/50-60	-	1200/1100	5,5 - 5,1	1470/1650	1"	YES	
FO033190A	VISCOMAT 70 T 400/50-60	D O B	25	7	6	85	-	400/50 - 400/60	650/1000	2,2 - 3,1	1450/1750	1"	YES	
VISCOMAT 90														
FO0303M00	VISCOMAT 90 M 230/50-60	D O B	50	13	5	71	230/50-60	-	1350/1600	6,2 - 4,9	1400/1600	1"	NO	
000303000	VISCOAMT 90 T 400/50	D O B	50	13	5	71	-	400/50	2000	5	1450	1"	YES	

UPON REQUEST IT IS AVAILABLE WITH DIFFERENT VOLTAGE AND FREQUENCY

VISCOMAT VANE



FUEL MANAGEMENT SYSTEMS



DISPENSERS



KITS



PUMPS



METERS



NOZZLES

E80 / E120

FEATURES

- VERSATILITY
- STURDY STRUCTURE
- LONG LASTING
- REASY TO USE
- THERMAL PROTECTION

The PIUSI E80 and E120 are self-priming rotary electric vane pumps, compact and easy to install, suitable to meet all those use requirements needing a high-performance and long lasting product. The sturdy structure along with the thermal protection and the top-quality components allow its use at low working temperatures.

PERFORMANCE

UP TO
100 L/MIN

FLOW RATE

AC
CONTINUOUS DUTY

POWER

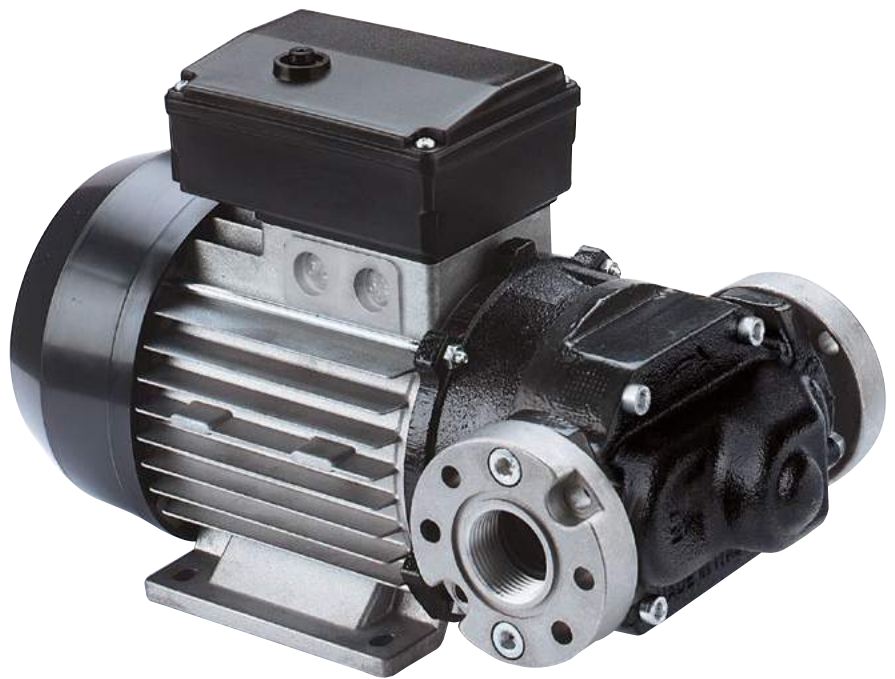

E80/E120



PACKAGING

CODE	WEIGHT		PACKAGING			N. BOXES / EUROPALLET	
	KG	LBS	MM	INCH	PCS/BOX		
E80							
000305000	13	28,7	355X185X285	-	1	60	72
000307000	13	28,7	355X185X285	-	1	60	72
E120							
000326000	15,6	34,4	355X185X285	-	1	60	72
000312000	15,6	34,4	355X185X285	-	1	60	72



FILTRATION



TANK MONITORING



HOSE REEL



ACCESSORIES



MERCHANDISE

INDEX



AIR



ANTIFREEZE



AdBlue®



BIODIESEL



DIESEL



FOOD



GASOLINE



GREASE



KEROSENE



OIL



WATER



WINDSCREEN

CHART

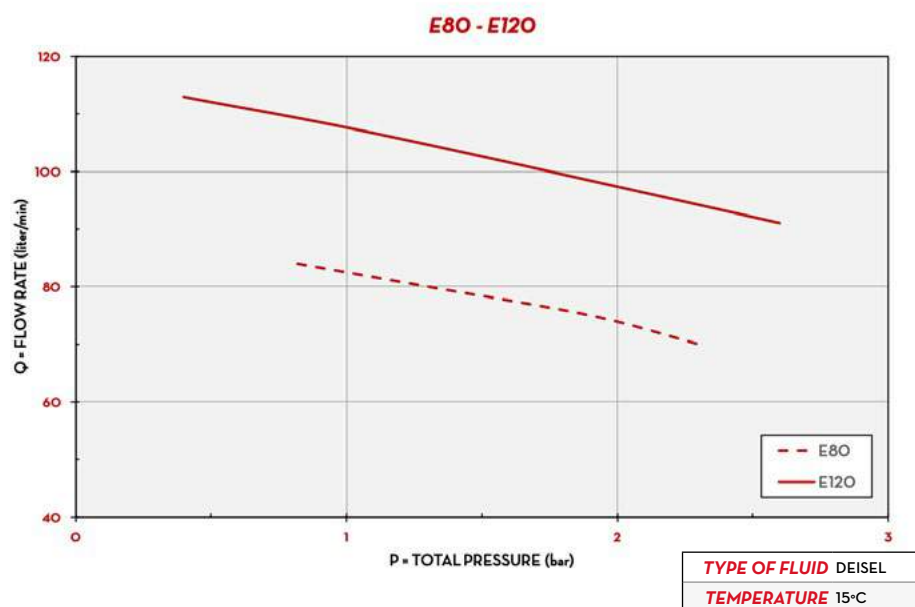

IN THE BOX

- E80/E120 PUMP
- FLANGED CONNECTION
- INSTRUCTION MANUAL

DETAILS



DIMENSIONS

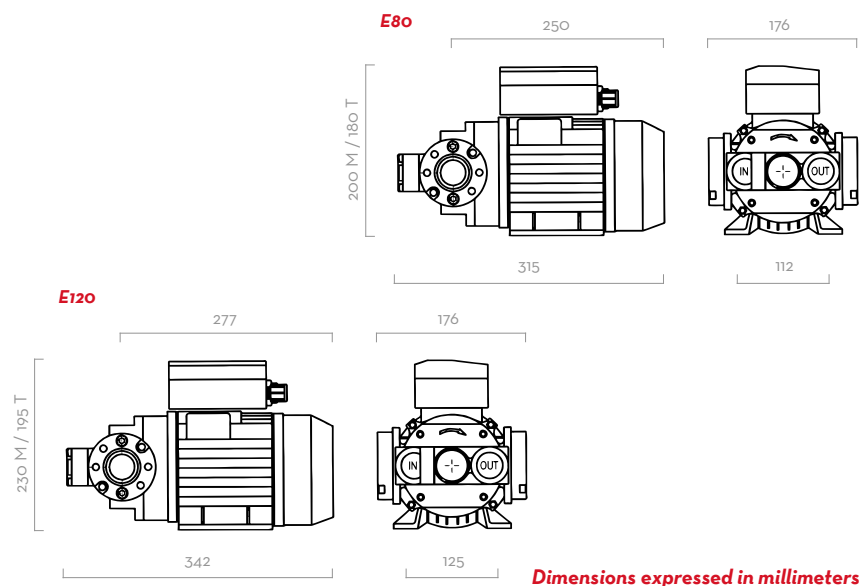

MATERIALS

- BODY: CAST IRON
- ROTOR: SINTERED STEEL
- VANES: ACETAL RESIN
- SEAL: VITON
- SHAFT: STEEL



PUMP

- > MAX 6M (20FT),
- > SUCTION HOSE Ø 1" MIN,
- > MAX SUCTION HEIGHT:
 - 2M (7FT) W/O NON RETURN VALVE
 - 4M (14FT) W NON RETURN VALVE



TANK

TECHNICAL DATA

CODE	DESCRIPTION	FLUIDS TYPE	FLOW RATE		VOLTAGE				RPM	INLET OUTLET		FLANGE CONNECTION	BYPASS VALVE	INLET FILTER
			L/MIN	GPM	SINGLEPHASE MOTOR V/Hz	THREEPHASE MOTOR V/Hz	POWER WATT	AMP. MAX.		BSP				
E 80														
000305000	E 80 M	D	70	18	230/50	-	500	3,5	1400	1"	YES	YES	NO	
000307000	E 80 T	D	70	18	-	400/50	550	1,6	1450	1"	YES	YES	NO	
E 120														
000326000	E 120 M	D	100	26	230/50	-	750	5,7	1450	1"	YES	YES	NO	
000312000	E 120 T	D	100	26	-	400/50	750	2,2	1450	1"	YES	YES	NO	

E80 / E120



FUEL MANAGEMENT SYSTEMS



DISPENSERS



KITS



PUMPS



METERS



NOZZLES

E140

FEATURES

- CONTINUOUS DUTY
- HIGH FLOW RATE
- HEAVY DUTY PUMP
- STURDY DESIGN

The E140 diesel transfer pump is versatile and suitable for different industries including automotive, agriculture, transportation, garages and construction. The E140 volumetric, self-priming vane pump for diesel transfer has a high seal and is reliable in conditions of use at low temperatures. With its solid and resistant body, the E140 is an easy to install diesel transfer pump, suitable for use in diesel dispensers and fixed fuel transfer systems, as well as other industrial applications. The compact cast iron structure makes the E140 electric pump the perfect system for performance and reliability.

PERFORMANCE

UP TO
140 L/MIN

FLOW RATE

AC
VOLTAGE
POWER



E140



PACKAGING

CODE	WEIGHT		PACKAGING			N. BOXES / EUROPALLET	
	KG	LBS	MM	INCH	PCS/BOX		
FO0395060	18	40	350X250X300	14X10X12	1	60	72
FO0395050	18	40	350X250X300	14X10X12	1	60	72



FILTRATION



TANK MONITORING



HOSE REEL



ACCESSORIES



MERCHANDISE

INDEX



AIR



ANTIFREEZE



AdBlue®



BIODIESEL



DIESEL



FOOD



GASOLINE



GREASE



KEROSENE



OIL



WATER



WINDSCREEN

CHART

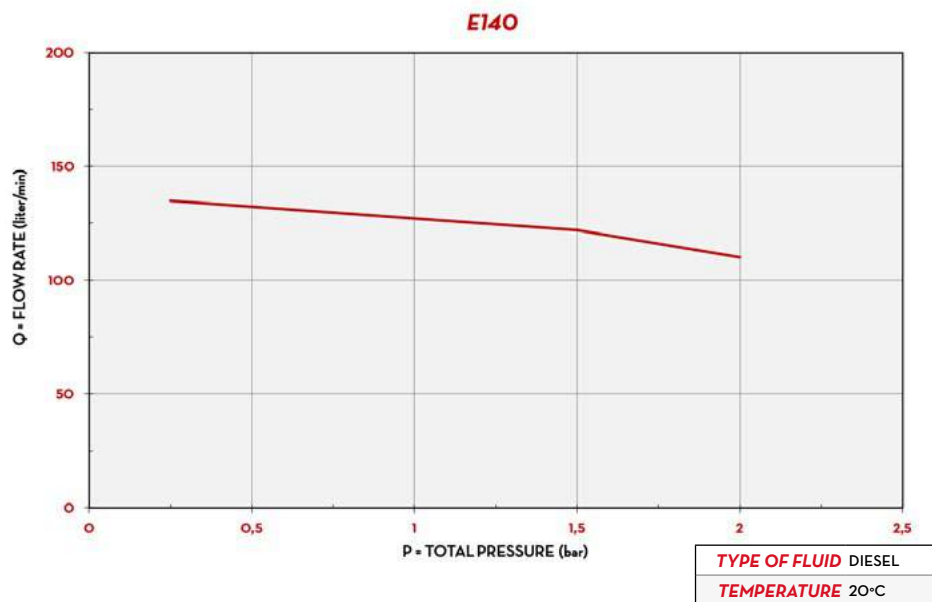

IN THE BOX

- E140 PUMP
- INSTRUCTION MANUAL

DETAILS



ON/OFF SWITCH



VANE ROTOR



BYPASS VALVE

DIMENSIONS

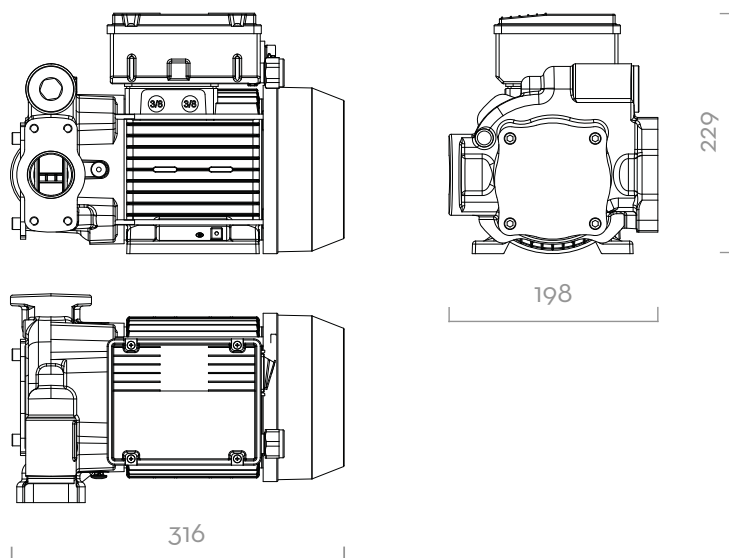

Dimensions expressed in millimeters

MATERIALS

- BODY: CAST IRON
- ROTOR: SINTERED STEEL
- VANES: TECHNOPYLIMER
- SEAL: VITON
- SHAFT: STEEL

TECHNICAL DATA

CODE	DESCRIPTION	FLUIDS TYPE	FLOW RATE		VOLTAGE			DUTY CICLE	RPM	OUTLET
			L/MIN	GPM	AC VOLT/Hz	POWER WATT	AMP. MAX.			
FO0395060	E 140 250/50	D	140	37	250/50	1150	5	S1	1450	1" 1/4
FO0395050	E 140 230/50	D	140	37	230/50	1150	5	S1	1450	1" 1/4

E140



FUEL MANAGEMENT SYSTEMS



DISPENSERS



KITS



PUMPS



METERS



NOZZLES

E300

FEATURES

- HIGH-FLOW PUMP
- STURDY STRUCTURE
- HEAVY DUTY APPLICATION
- IP44

The PIUSI E300 is an electric pump with open impeller suitable for all applications in which high-flows are required. Thus, it is the ideal equipment for topping up and transferring diesel from drums. It comes with an incorporated check valve in the suction port to prevent the siphon effect while ensuring automatic re-priming.

PERFORMANCE

UP TO

550 L/MIN

FLOW RATE

AC

CONTINUOUS DUTY

POWER

1,8 BAR

MAX

OPERATING PRESSURE

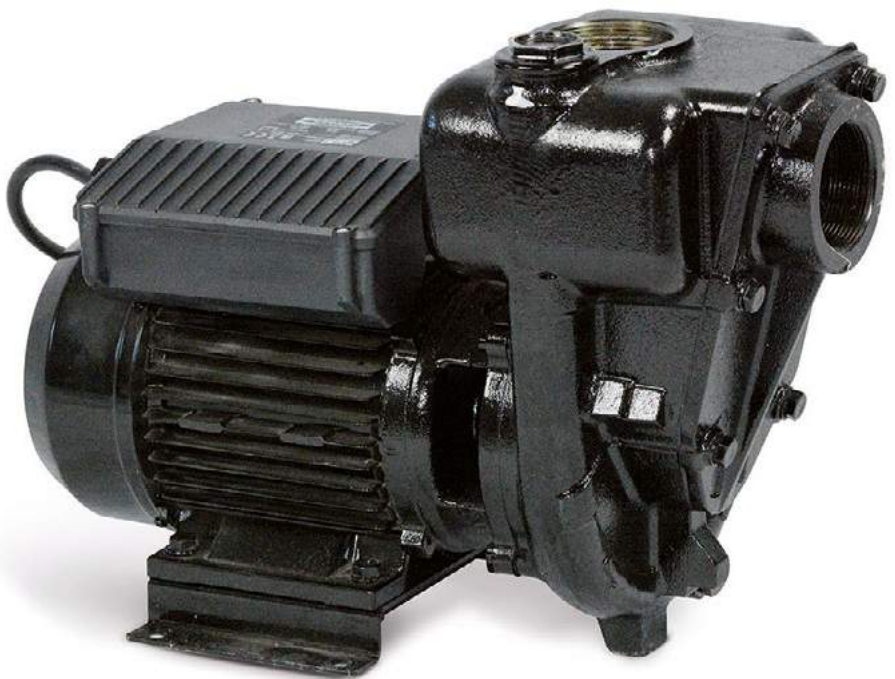

E300



PACKAGING

CODE	WEIGHT		PACKAGING		
	KG	LBS	MM	INCH	PCS/BOX
FO0321000	28	61,7	220X420X330	8,7X16,5X13	1



FILTRATION



TANK MONITORING



HOSE REEL



ACCESSORIES



MERCHANDISE

INDEX



AIR



ANTIFREEZE



AdBlue®



BIODIESEL



DIESEL



FOOD



GASOLINE



GREASE



KEROSENE



OIL



WATER



WINDSCREEN

CHART



TYPE OF FLUID DIESEL
TEMPERATURE 10°C

DIMENSIONS

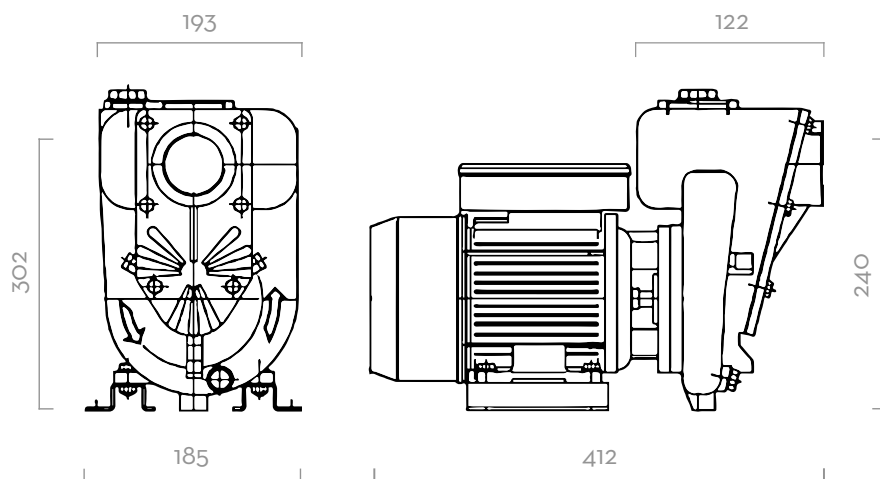

Dimensions expressed in millimeters

IN THE BOX

- E300 PUMP
- INSTRUCTION MANUAL

DETAILS



OPEN IMPELLER



2" IN/OUT CONNECTIONS



STEADY SUPPORT

MATERIALS

- BODY: CAST IRON
- ROTOR: SINTERED STEEL
- VANES: ACETAL RESIN
- SEAL: VITON
- SHAFT: STEEL

TECHNICAL DATA

CODE	DESCRIPTION	FLUIDS TYPE	FLOW RATE		VOLTAGE			RPM	INLET/OUTLET
			L/MIN	GPM	AC VOLT/HZ	POWER WATT	AMP. MAX.		BSP
FO0321000	E 300	D	550	132	230/50	1500	9,2	2580	2"

E300



FUEL MANAGEMENT SYSTEMS



DISPENSERS



KITS



PUMPS



METERS



NOZZLES

BP3000

FEATURES

- VERSATILE
- ON BOARD APPLICATION
- EMC COMPATIBILITY
- VIBRATION RESISTANT
- IP55

The PIUSI BP3000 is a long-lasting, self-priming vane pump. Powerful, versatile and compact, it is equipped with a built-in by-pass valve. Available in both 12V and 24V versions, it represents the core of the PIUSI range of pumps for on-board applications, particularly in the off-road and earthmoving machinery industry.



BP3000 INLINE



BP3000

PERFORMANCE

UP TO
50 L/MIN

FLOW RATE

DC
VOLTAGE
POWER

30 MIN

DUTY CICLE

UP TO
4MT

SELF-PRIMING

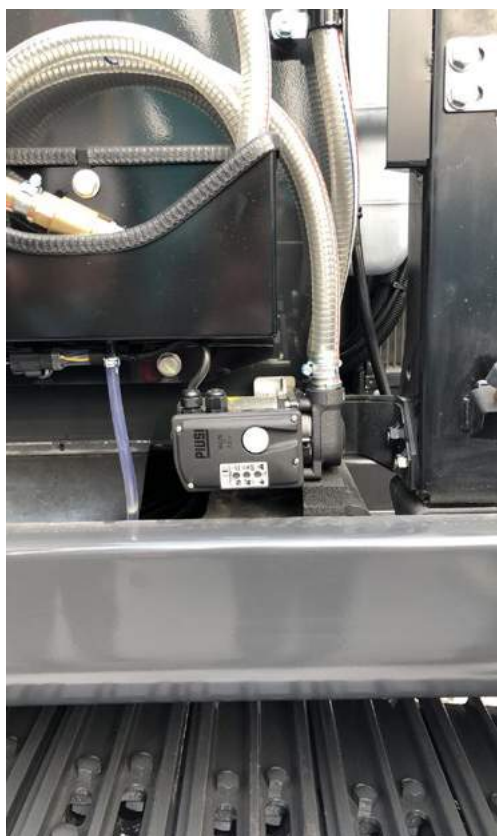

PACKAGING

CODE	WEIGHT		PACKAGING		
	KG	LBS	MM	INCH	PCS/BOX
FO0342000	3,5	7,9	200X120X140	7,9X4,7X5,5	1
FO0347000	3,5	7,9	200X120X140	7,9X4,7X5,5	1
FO0357000	3,5	7,9	200X120X140	7,9X4,7X5,5	1
FO0357500	3,5	7,9	200X120X140	7,9X4,7X5,5	1
FO0358000	3,5	7,9	200X120X140	7,9X4,7X5,5	1
FO0358500	3,5	7,9	200X120X140	7,9X4,7X5,5	1



FILTRATION



TANK MONITORING



HOSE REEL



ACCESSORIES



MERCHANDISE

INDEX



AIR



ANTIFREEZE



AdBlue®



BIODIESEL



DIESEL



FOOD



GASOLINE



GREASE



KEROSENE



OIL



WATER



WINDSCREEN

CHART

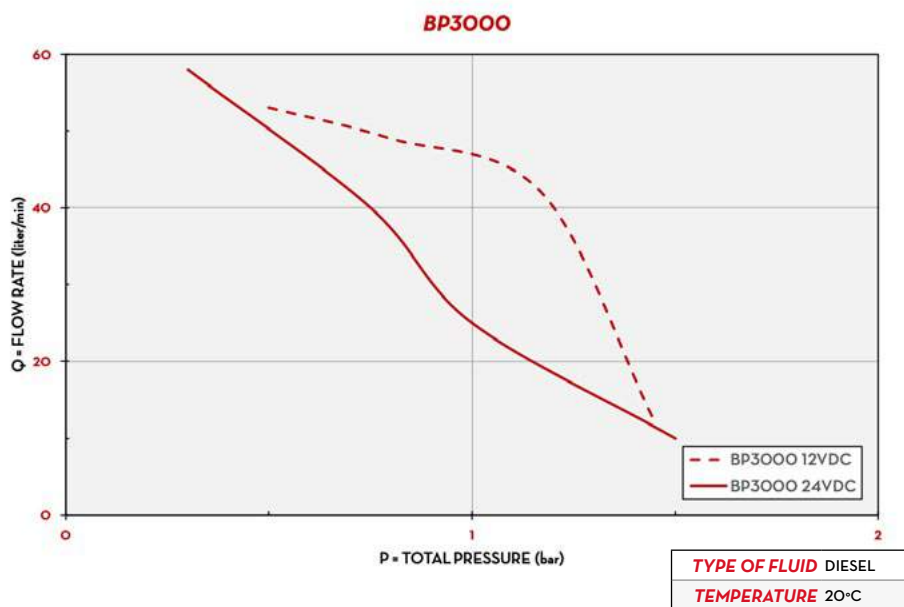

DIMENSIONS

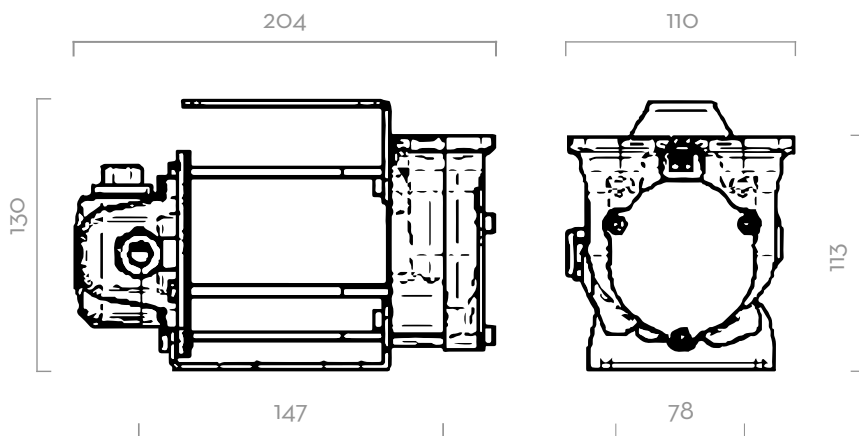

Dimensions expressed in millimeters

TECHNICAL DATA

CODE	DESCRIPTION	FLUIDS TYPE	FLOW RATE		VOLTAGE			DUTY CICLE		RPM	THREADED PORTS BSP	MAX WORKING PRESSURE BAR
			L/MIN	GPM	DC VOLT	POWER WATT	AMP. MAX.	MINUTES				
FO0342000	BP3000 12V	D	50	13	12	300	24	30	2900	-	1,5	
FO0347000	BP3000 24V	D	50 / 30	13 / 6	24/12	310 / 80	13 / 6,5	30	2900 / 1500	-	1,5	
FO0357000	BP3000 12V INLINE	D	50	13	12	300	24	30	2900	-	1,5	
FO0357500	BP3000 12V INLINE 3/4" BSP	D	50	13	12	300	24	30	2900	3/4"	1,5	
FO0358000	BP3000 24V INLINE	D	50 / 30	13 / 6	24/12	310 / 80	13 / 6,5	30	2900 / 1500	-	1,5	
FO0358500	BP3000 24V INLINE 3/4" BSP	D	50 / 30	13 / 6	24/12	310 / 80	13 / 6,5	30	2900 / 1500	3/4"	1,5	

IN THE BOX

- BP3000 PUMP
- INSTRUCTION MANUAL

DETAILS



MATERIALS

- BODY: CAST IRON
- ROTOR: SINTERED STEEL
- VANES: ACETAL RESIN
- SEAL: NBR
- SHAFT: STEEL



FUEL MANAGEMENT SYSTEMS



DISPENSERS



KITS



PUMPS



METERS



NOZZLES

PANTHER DC

FEATURES

- STURDY STRUCTURE
- EASY TO INSTALL
- COMPACT DESIGN
- IP55

The PANTHER DC is a rotary, self-priming vane pump suitable for all applications in which important flow rates are required. This equipment is fitted with an incorporated filter (100µ) and by-pass valve. The 24/12 V version can be used with both voltages.

PERFORMANCE

UP TO

70 L/MIN

FLOW RATE

12/24V

VOLTAGE

POWER

30 MIN

DUTY CICLE



PANTHER DC



PACKAGING

CODE	WEIGHT		PACKAGING		
	KG	LBS	MM	INCH	PCS/BOX
FO034000B	7,5	16,5	345X175X255	13,6X6,9X10	1
FO034001B	7,5	16,5	345X175X255	13,6X6,9X10	1
FO034100C	7,5	16,5	345X175X255	13,6X6,9X10	1
FO034101C	7,5	16,5	345X175X255	13,6X6,9X10	1
FO034116C	7,5	16,5	345X175X255	13,6X6,9X10	1



FILTRATION



TANK MONITORING



HOSE REEL



ACCESSORIES



MERCHANDISE

INDEX



AIR



ANTIFREEZE



AdBlue®



BIODIESEL



DIESEL



FOOD



GASOLINE



GREASE



KEROSENE



OIL



WATER



WINDSCREEN

CHART

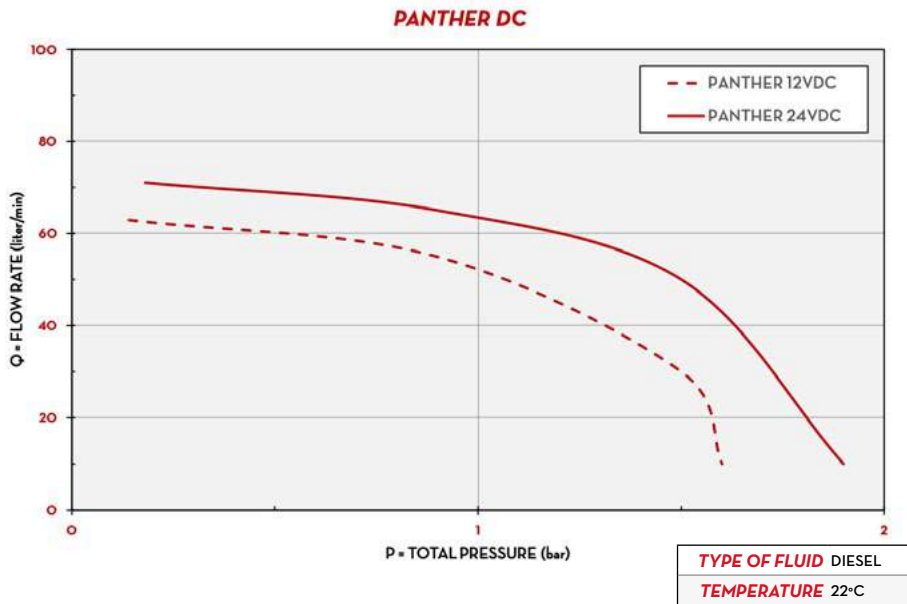

DIMENSIONS

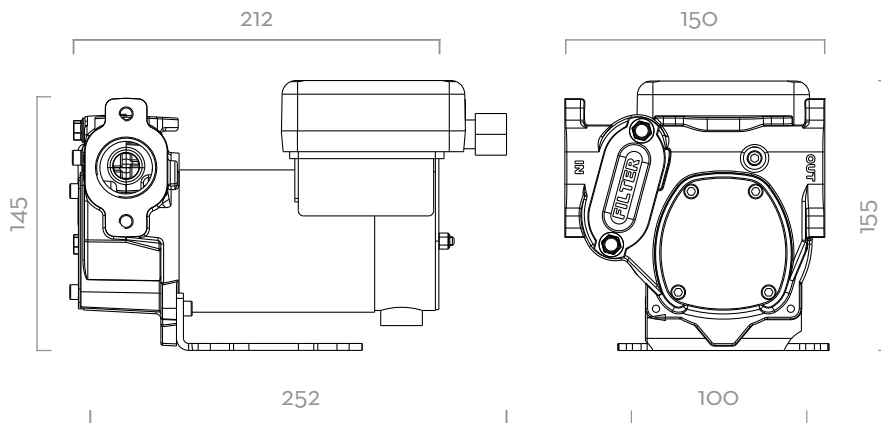

Dimensions expressed in millimeters

IN THE BOX

- PANTHER DC PUMP
- INSTRUCTION MANUAL

DETAILS



ON/OFF SWITCH



1" BSP THREADED



INTEGRATED FILTER

MATERIALS

- BODY: CAST IRON
- ROTOR: SINTERED STEEL
- VANES: ACETAL RESIN
- MOTOR: ALUMINIUM CASING



PUMP

- > MAX 6M (20FT),
- > SUCTION HOSE Ø 1" MIN,
- > MAX SUCTION HEIGHT:
 - 2M (7FT) W/O NON RETURN VALVE
 - 4M (14FT) W NON RETURN VALVE



TANK

TECHNICAL DATA

CODE	DESCRIPTION	FLUIDS TYPE	FLOW RATE		VOLTAGE			DUTY CICLE	RPM	OUTLET
			L/MIN	GPM	DC VOLT	POWER WATT	AMP. MAX.			
FO034000B	PANTHER DC 12V	D	56	14,8	12	300	35	30	2900	1"
FO034001B	PANTHER DC 12V W/CABLE 2MT W/PLIERS	D	56	14,8	12	300	35	30	2900	1"
FO034100C	PANTHER DC 24/12V	D	70 / 35	18,5 / 9,2	24/12	420 / 150	25 / 16	30	3600 / 1800	1"
FO034101C	PANTHER DC 12/24V W/CABLE 2MT W/CLIPS	D	70 / 35	18,5 / 9,2	24/12	420 / 150	25 / 16	30	3600 / 1800	1"
FO034116C	PANTHER DC 12/24V W/CABLE 4MT W/CLIPS	D	70 / 35	18,5 / 9,2	24/12	420 / 150	25 / 16	30	3600 / 1800	1"

PANTHER DC



FUEL MANAGEMENT SYSTEMS



DISPENSERS



KITS



PUMPS



METERS



NOZZLES

BIPUMP

FEATURES

- STURDY STRUCTURE
- COMPACT DESIGN
- HEAVY DUTY
- HIGH RELIABILITY
- IP55

The PIUSI BIPUMP is a diesel transfer pump, available both in 12 and 24 V versions, designed to meet the needs of those who are looking for a long-lasting quality, high flow rate pump, applicable to different industries. It is easy to install and is suitable for being applied on diesel dispensers and fixed fuel transfer systems, as well as other applications.

PERFORMANCE

UP TO

85 L/MIN

FLOW RATE

12/24V

VOLTAGE

POWER

30 MIN

DUTY CICLE



BIPUMP



PACKAGING

CODE	WEIGHT		PACKAGING			N. BOXES / EUROPALLET	
	KG	LBS	MM	INCH	PCS/BOX	✕	
FOO363A0A	9,9	21,8	345X175X255	-	1	60	72
FOO363B0A	9,9	21,8	345X175X255	-	1	60	72
FOO36301A	9,9	21,8	345X175X255	-	1	60	72
FOO36302A	9,9	21,8	345X175X255	-	1	60	72
FOO36303A	9,9	21,8	345X175X255	-	1	60	72
FOO36304A	9,9	21,8	345X175X255	-	1	60	72
FOO36321A	9,9	21,8	345X175X255	-	1	60	72
FOO363380	9,9	21,8	345X175X255	-	1	60	72



FILTRATION



TANK MONITORING



HOSE REEL



ACCESSORIES



MERCHANDISE

INDEX



AIR



ANTIFREEZE



AdBlue®



BIODIESEL



DIESEL



FOOD



GASOLINE



GREASE



KEROSENE



OIL



WATER



WINDSCREEN

CHART

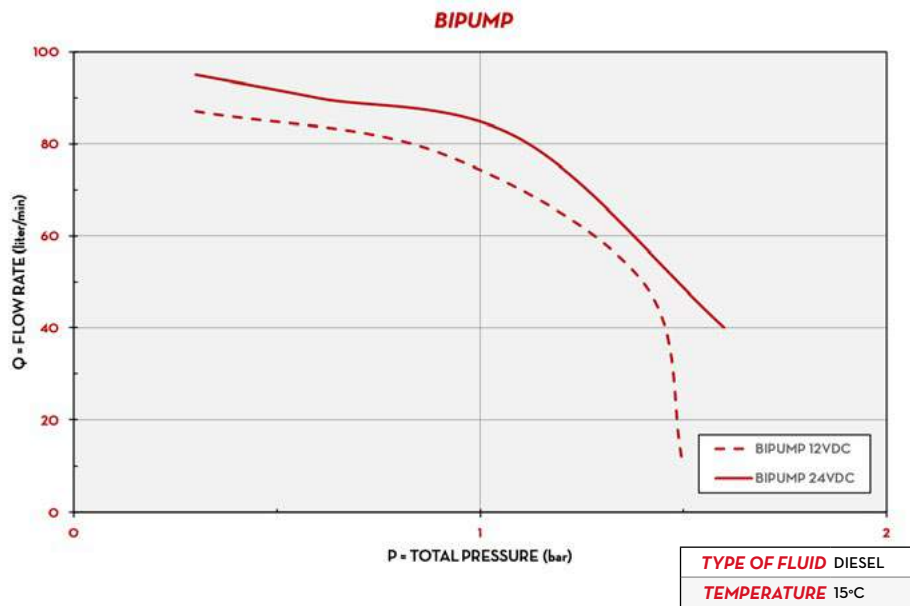

IN THE BOX

- BIPUMP UNIT
- FLANGED CONNECTIONS
- INSTRUCTION MANUAL

DETAILS



DIMENSIONS

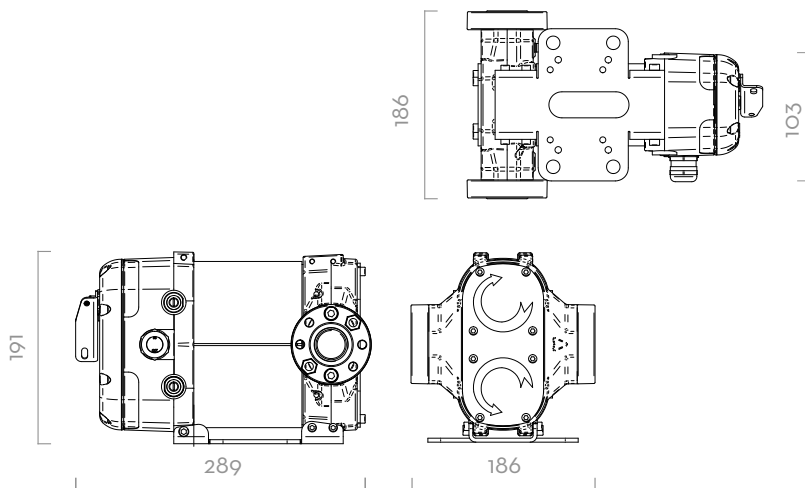

Dimensions expressed in millimeters

MATERIALS

- BODY: CAST IRON
- ROTOR: SINTERED STEEL
- VANES: ACETAL RESIN
- SEAL: NBR
- SHAFT: STEEL



PUMP

- > MAX 6M (20FT),
- > SUCTION HOSE Ø 1" MIN,
- > MAX SUCTION HEIGHT:
- 2M (7FT) W/O NON RETURN VALVE
- 4M (14FT) W NON RETURN VALVE



TANK

TECHNICAL DATA

CODE	DESCRIPTION	FLUIDS TYPE	FLOW RATE		VOLTAGE			DUTY CYCLE	RPM	OUTLET
			L/MIN	GPM	DC VOLT	POWER WATT	AMP. MAX.			
FOO363A0A	BIPUMP 12V WITH ON/OFF SWITCH	D	85	22,4	12	500	42	30	2000	1"
FOO363B0A	BIPUMP 24V WITH ON/OFF SWITCH	D	85	22,4	24	500	21	30	2000	1"
FOO36301A	BIPUMP 12V WITH CABLE 2M	D	85	22,4	12	500	42	30	2000	1"
FOO36302A	BIPUMP 12V WITH CABLE 4M	D	85	22,4	12	500	42	30	2000	1"
FOO36303A	BIPUMP 24V WITH CABLE 2M	D	85	22,4	24	500	21	30	2000	1"
FOO36304A	BIPUMP 24V WITH CABLE 4M	D	85	22,4	24	500	21	30	2000	1"
FOO36321A	BIPUMP 12/24 WITHOUT ON/OFF SWITCH	D	85	22,4	12/24	500/500	42/21	30/30	2000	1"
FOO363380	BIPUMP 12V W/SWITCH W/CABLE 6M	D	85	22,4	12	500	42	30	2000	1"

BIPUMP



FUEL MANAGEMENT SYSTEMS



DISPENSERS



KITS



PUMPS



METERS



NOZZLES

PIUSI HAND PUMP

FEATURES

- OPTIMIZED SUCTION CAPACITY
- STURDY CONNECTOR
- HEAVY DUTY LEVER
- FLUENT REVOLUTION
- HIGH EFFICIENCY
- ADJUSTABLE SUCTION PIPE

The PIUSI HAND PUMP is a rotary vane pump suitable for transferring low viscosity oils and diesel. Entirely designed, manufactured and certified in Italy, this sturdy pump guarantees a professional performance and easy transfer.

PERFORMANCE

UP TO

38L

PER 100 REVOLUTIONS

FLOW RATE

3MT

LENGTH

DELIVERY HOSE



PIUSI HAND PUMP WITH HOSE AND STAINLESS STEEL SPOUT



PACKAGING

CODE	WEIGHT		PACKAGING			N. BOXES / EURO PALLET	
	KG	LBS	MM	INCH	PCS/BOX	✈	🚚
WITHOUT HOSE							
FOO33250A	2,1	4,6	350X170X140	-	1	50	100
WITH HOSE							
FOO33252A	3,2	7	300X300X180	-	1	50	100



FILTRATION



TANK MONITORING



HOSE REEL



ACCESSORIES



MERCHANDISE

INDEX



AIR



ANTIFREEZE



AdBlue®



BIODIESEL



DIESEL



FOOD



GASOLINE



GREASE



KEROSENE



OIL



WATER



WINDSCREEN

CHART

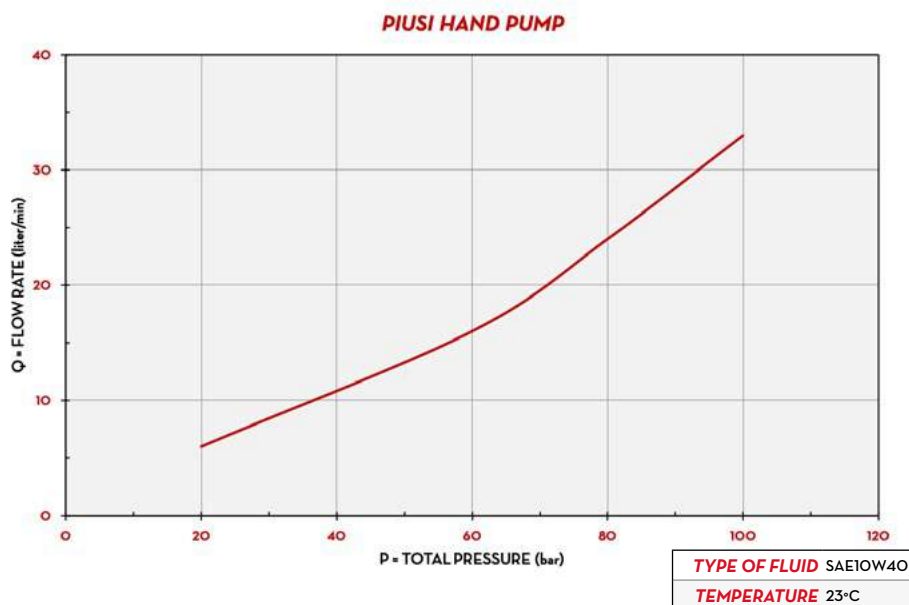

DIMENSIONS

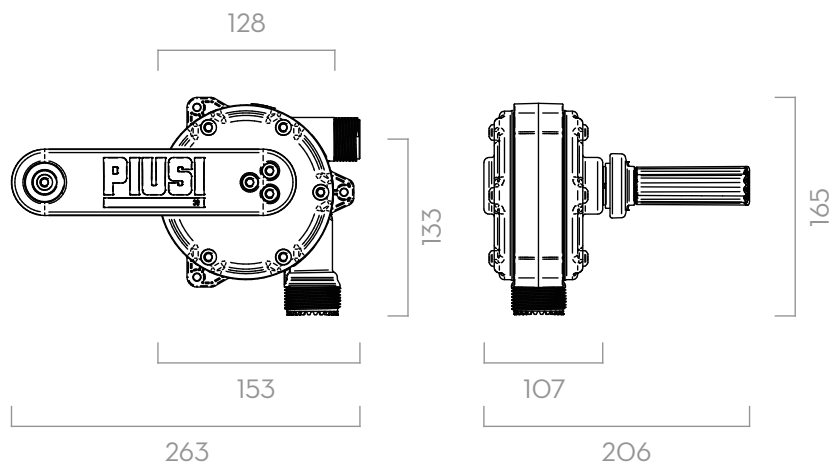

Dimensions expressed in millimeters

IN THE BOX

- PIUSI HAND PUMP
- SPOUT
- SUCTION PIPE
- DRUM CONNECTOR
- INSTRUCTION MANUAL

DETAILS



2" BSP DRUM CONNECTOR



SUCTION PIPE



NON-SLIP HANDLE



STAINLESS STEEL SPOUT

MATERIALS

- BODY: STAINLESS STEEL,
- TECHNOPOLYMER
- ROTOR: TECHNOPOLYMER
- VANES: TECHNOPOLYMER

TECHNICAL DATA

CODE	DESCRIPTION	FLUIDS TYPE	CAPACITY PER 100 REVOLUTIONS		DRUM CONNECTOR	SUCTION TUBE	"S" SPOUT AND HOSE TAIL	DELIVERY HOSE LENGTH
			L	USG				
WITHOUT HOSE								
FO033250A	PIUSI HAND PUMP 2" BSP	D O	38	10	2" BSP	YES	YES	-
WITH HOSE								
FO033252A	KIT PIUSI HAND PUMP 2" BSP WITH HOSE	D O	38	10	2" BSP	YES	-	3M

PIUSI HAND PUMP



FUEL MANAGEMENT SYSTEMS



DISPENSERS



KITS



PUMPS



METERS



NOZZLES

HAND PUMPS

FEATURES

- STURDY CONNECTOR
- SUCTION PIPE INCLUDED
- MULTI-PURPOSE PUMPS

Besides the top-quality Hand Pump, PIUSI offers a range of HAND PUMPS with different characteristics - piston or rotary - and fittings to transfer fluids from drums.

PERFORMANCE

UP TO

90L

PER 100 REV

FLOW RATE

UP TO

1100MM

LENGTH

SUCTION HOSE



PM GPI PISTON

PACKAGING

CODE	WEIGHT		PACKAGING			N. BOXES / EUROPALLET	
	KG	LBS	MM	INCH	PCS/BOX	✕	
FO031600A	5,3	11,7	465X395X240	-	1	30	40
FO033200B	5,6	12,3	340X160X125	-	1	120	144
FO033201B	5,3	11,7	465X395X240	-	1	120	144
FO034900A	3,0	6,6	600X110X65	-	1	160	240
FO035100A	3,0	6,6	300X150X105	-	1	160	200



FILTRATION



TANK MONITORING



HOSE REEL



ACCESSORIES



MERCHANDISE

INDEX



AIR



ANTIFREEZE



AdBlue®



BIODIESEL



DIESEL



FOOD



GASOLINE



GREASE



KEROSENE



OIL



WATER



WINDSCREEN



PISTON HAND PUMP



CAST IRON ROTATIVE



ALUMINIUM ROTATIVE



PISTON HAND PUMP

IN THE BOX

- ROTARY/PISTON PUMP
- SUCTION TUBE
- CONNECTOR/ADAPTOR
- SPOUT/DELIVERY HOSE
- INSTRUCTION MANUAL

DETAILS



NON-SLIP HANDLE

MATERIALS

- BODY: IRON/STAINLESS STEEL/ALUMINIUM

TECHNICAL DATA

CODE	DESCRIPTION	FLUIDS TYPE	CAPACITY	INLET / OUTLET	SUCTION HOSE LENGTH MM
			L / 100REV		
FOO31600A	PM GPI PISTON	O D G K	90	1-3/4" NPT	1100
FOO33200B	ALUMINIUM ROTATIVE HAND PUMP	O D G K	27	M32 X 1,5 - M25 X 1,5	960
FOO33201B	CAST IRON ROTATIVE HAND PUMP	D O	25	M32 X 1,5 - M25 X 1,5	960
FOO34900A	PISTON HAND PUMP 25 L/M	D O	25	END HOSE Ø 20	880
FOO35100A	PISTON HAND PUMP 35 L/M	D O	35	END HOSE Ø 20	880



HAND PUMPS



PUMPS ACCESSORIES



ATEX AC/DC

EX50	CODE	DESCRIPTION
	F1862600A	(EX)CABLE+CABLEGLAND ECEX EX50 12V
	F1815600B	(EX) ADAPTER FOR CONDUIT EX50







F1815600B
F1862600A

EX100	CODE	DESCRIPTION
	F21770000	BUNG ADAPTER 2" BSP COMPLETE
	F22436010	ANTISIPHON KIT FOR EX100/EX140/E140 BSP
	F22053000	MOTOR SUPPORT FEET EX80/100/140

F22436010
F22053000
F21770000



EX140	CODE	DESCRIPTION
	F21770000	BUNG ADAPTER 2" BSP COMPLETE
	F22436010	ANTISIPHON KIT FOR EX100/EX140/E140 BSP
	F22053000	MOTOR SUPPORT FEET EX80/100/140

F22436010
F22053000
F21770000



HAND PUMPS



PIUSI HAND PUMP	CODE	DESCRIPTION
	F15236000	ADATTATORE M/F 2IN - 56X4 ADBLUE
	R1512800A	ADAPTER M/F 2" - S7OX6 ADBLUE





R1512800A
F15236000

AC/DC PUMPS



E80 / E120	CODE	DESCRIPTION	
	F1392000A	KIT ANTI-SYPHON FOR P56/72 E80/120	 F1392000A



E140	CODE	DESCRIPTION	
	F22436010	ANTISIPHON KIT FOR EX100/EX140/E140 BSP	 F22436010



BP3000	CODE	DESCRIPTION	
	F1701800A	KIT TERMINAL BOX+4M CABLE W\CLAMP 12-24V	 R1601100B F1701800A F1729000A F1728900A
	F1728900A	KIT TERMINAL BOX+2M CABLE W\CLAMP 12-24V	
	F1729000A	KIT TERMINAL BOX+6M CABLE W\CLAMP 12-24V	
	R1601100B	ELECTRICAL BOX WITH SWITCH BP3000	

SPECIFIC CONNECTIONS FOR BP3000

	F1617300A	LP 3/4 90° HOSE TAIL KIT (1 PCS.)		F16178000	LP 90° FLANGED ELBOW-NEW
	F1726200A	HOSE TAIL 90° 1"		F16770000	KIT N.1 ELBOW 90° WITHOUT FLANGE

	F16172000	LP 3/4 STRAIGHT HOSE TAIL KIT (2 PCS.)-N		F16799000	FLANGED ADAPTER BP3000-VANTAGE 1" G-F
	F17124000	STRAIGHT HOSE TAIL 1" BP3000		F17313000	FLANGED ADAPTER BP3000 \ VANTAGE 1ING -
				F17314000	FLANGED ADAPTER BP3000\ VANTAGE 3/4ING -F

PANTHER DC	CODE	DESCRIPTION	
	F1001100A	CABLE 2X6X2 MT EYELET TERMINAL 12V	 R10011000 R10040000 R10041000 R10039000 R13242000
	F1004000A	CABLE 2X6X2 MT EYELET TERMINAL 24V	
	F1004100A	CABLE 2X6X4 MT EYELET TERMINAL 12V	
	F1003900A	CABLE 2X6X4 MT EYELET TERMINAL 24V	
	R13242000	KIT HANDLE PANTHER DC	

BIPUMP	CODE	DESCRIPTION	
	F1420000B	KIT HANDLE BIPUMP	 R14334000 R14335000 R1420000A
	F1433400A	CABLE 2X6X2MT BIPUMP	
	F1433500A	CABLE 2X6X4MT BIPUMP	

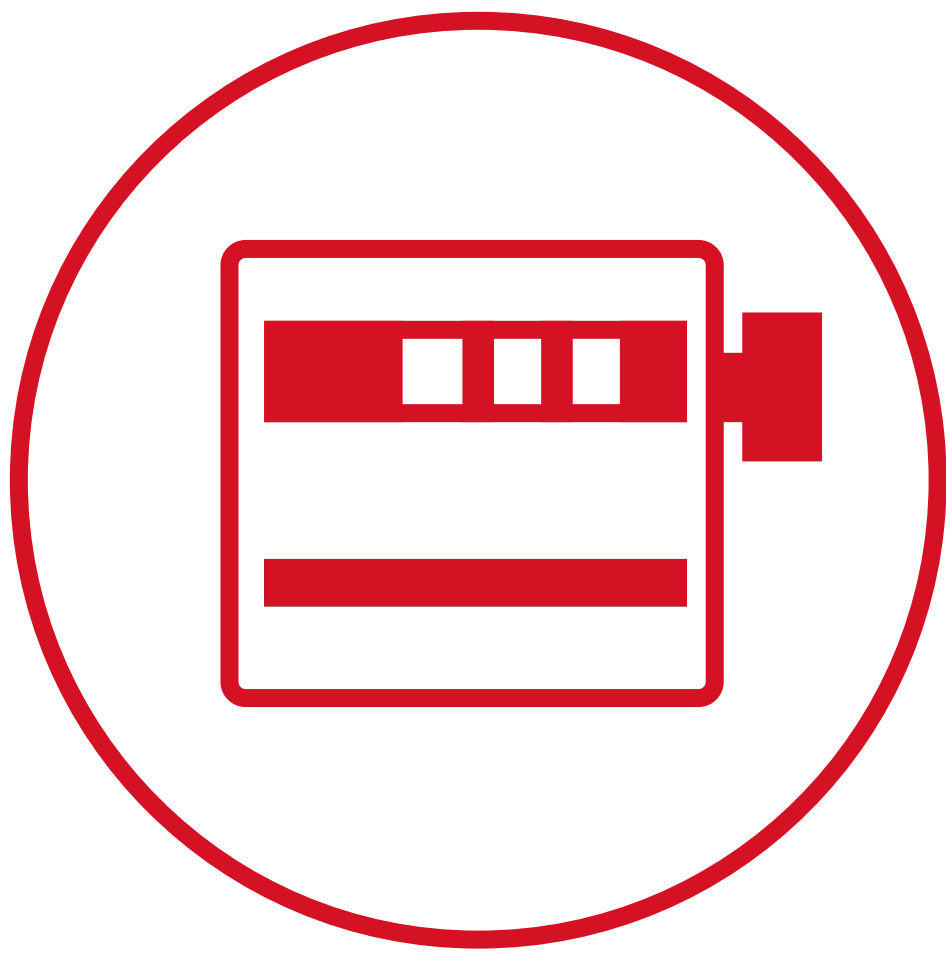

METERS





FUEL MANAGEMENT SYSTEMS



DISPENSERS



KITS



PUMPS



METERS



NOZZLES

K24 ATEX



FEATURES

- BURSTING PRESSURE 100 BAR
- LCD DISPLAY
- FLOW RATE INDICATION
- EASY TO CALIBRATE
- UL VERSION AVAILABLE

The PIUSI K24 ATEX, specifically designed to be compliant with ATEX/IECEX requirements, is manufactured using high-quality materials compatible with gasoline, kerosene and diesel to be used in potentially explosive areas. This turbine flow meter is equipped with a 6-digit totalizer and partial reset.

PERFORMANCE

7-120

L/MIN

FLOW RATE

20 BAR

MAX

OPERATING PRESSURE

± 1%

ACCURACY

0,3%

REPEATABILITY



K24 ATEX / IECEX

OUR PRODUCT COMPLIES WITH THE FOLLOWING MARKING ATEX/IECEX

II	2	G	Ex	ia	IIB	T4	Gb
GROUP	CATEGORY	TYPE OF EXPLOSIVE ATMOSPHERE	PERMANENT PREFIX	PROTECTION METHOD	GAS GLASS	TEMPERATURE CLASS	EQUIPMENT PROTECTION LEVEL

PACKAGING

CODE	WEIGHT		PACKAGING		
	KG	LBS	MM	INCH	PCS/BOX
K24 A ATEX/IECEX METER					
FOO408X00	0,5	1,1	115X160X135	4,5X6,3X5,3	1
K24 A ATEX/IECEX PULSER					
FOO408Y00	0,5	1,1	115X160X135	4,5X6,3X5,3	1





FILTRATION



TANK MONITORING



HOSE REEL



ACCESSORIES



MERCHANDISE

INDEX



AIR



ANTIFREEZE



AdBlue®



BIODIESEL



DIESEL



FOOD



GASOLINE



GREASE



KEROSENE



OIL



WATER



WINDSCREEN

CHART

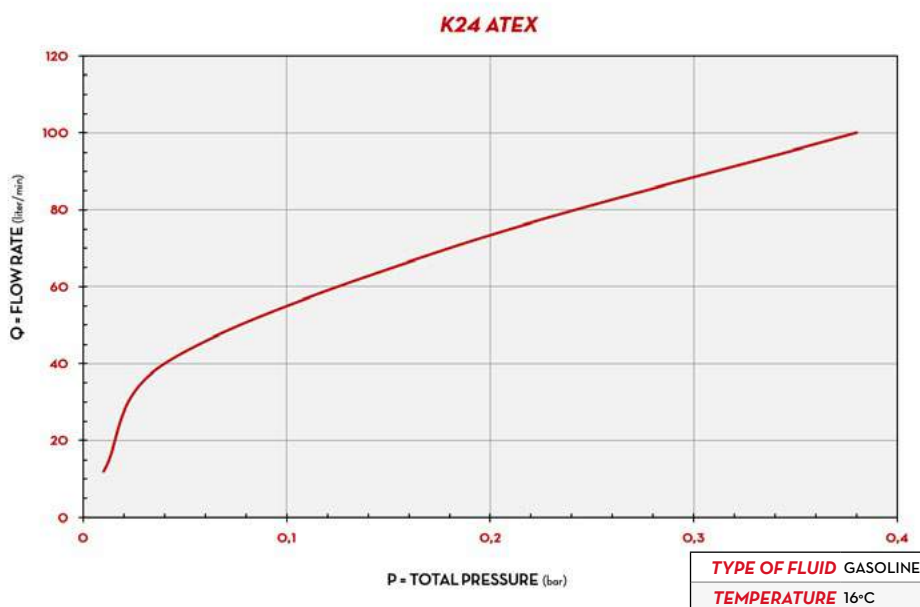

DIMENSIONS

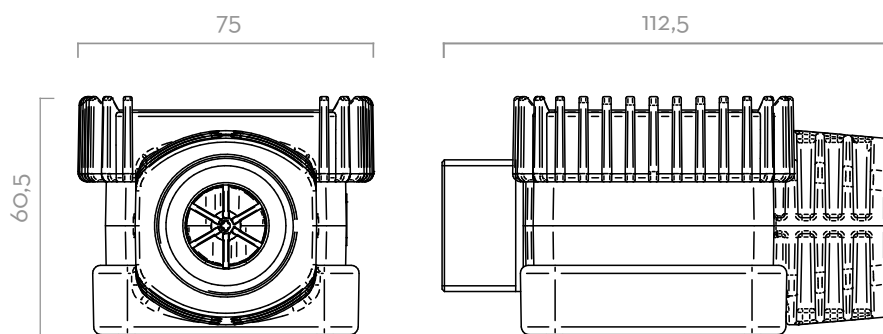

Dimensions expressed in millimeters

IN THE BOX

- K24 ATEX METER
- INSTRUCTION MANUAL

DETAILS



MATERIALS

- BODY: ALUMINIUM
- GEARS: TECHNOPOLYMER

TECHNICAL DATA

CODE	DESCRIPTION	FLUIDS TYPE	FLOW RATE		PRESSURE		SPECIAL BATTERY INCLUDED N° 1.3V LITHIUM	FLANGE	INLET / OUTLET
			L/MIN	GPM	BAR	PSI			
K24 A ATEX/IECEX METER									
FO0408X00	K24 A M/F 1" BSP ATEX/IECEX	D G K	7 - 120	2 - 32	20	300	YES	NO	M 1" BSP - F 1" BSP
K24 A ATEX/IECEX PULSER									
FO0408Y00	K24 A PULSER M/F 1" BSP ATEX/IECEX (92 PULSE/L)	D G K	7 - 120	2 - 32	20	300	NO	NO	M 1" BSP - F 1" BSP

FLUIDS PERMITTED: DIESEL, KEROSENE, PETROL, PETROL ALCOHOL MIXED MAX 20%, AVGAS 100/100LL (PUMP ONLY), JET A/AT (PUMP ONLY) - ASPEN 2/4. UL CLASSIFIED VERSION AVAILABLE

K24 ATEX



FUEL MANAGEMENT SYSTEMS



DISPENSERS



KITS



PUMPS



METERS



NOZZLES

K33 ATEX



FEATURES

- BURSTING PRESSURE 28 BAR
- 3 DIGIT DISPLAY
- EASY TO CALIBRATE
- 4 FLOW DIRECTIONS

The PIUSI K33 ATEX is an oval gear mechanical meter engineered for an accurate measuring of the quantity of fluid dispensed that meets the ATEX/IECEX requirements related to the use in potentially explosive atmospheres. Reliable and easy to install, it can be calibrated on site and simply fitted with both rigid or flexible pipes or can be put directly on pumps and tanks.

PERFORMANCE

20-120

L/MIN

FLOW RATE

3,5 BAR

MAX

OPERATING PRESSURE

± 1%

ACCURACY

0,3%

REPEATABILITY



K33 - ATEX



OUR PRODUCTS COMPLIES WITH THE FOLLOWING MARKING ATEX

II	2	G	c	IIB	T6
GROUP	CATEGORY	TYPE OF EXPLOSIVE ATMOSPHERE	PROTECTION METHOD	GAS GLASS	TEMPERATURE CLASS

PACKAGING

CODE	WEIGHT		PACKAGING			N. BOXES / EUROPALLET	
	KG	LBS	MM	INCH	PCS/BOX		
FO057000A	0,6	1,3	180X180X170	-	1	192	240
FO057001A	0,6	1,3	180X180X170	-	1	192	240
FO057002A	0,6	1,3	180X180X170	-	1	192	240
FO057003A	0,6	1,3	180X180X170	-	1	192	240



FILTRATION



TANK MONITORING



HOSE REEL



ACCESSORIES



MERCHANDISE

INDEX



AIR



ANTIFREEZE



AdBlue®



BIODIESEL



DIESEL



FOOD



GASOLINE



GREASE



KEROSENE



OIL



WATER



WINDSCREEN

CHART



DIMENSIONS

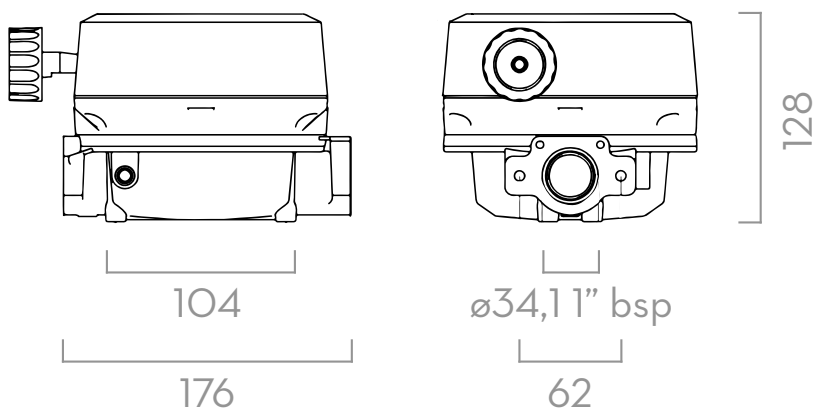

Dimensions expressed in millimeters

IN THE BOX

- K33 ATEX METER
- INSTRUCTION MANUAL

DETAILS



NUTATING DISK SYSTEM



4 FLOW DIRECTIONS



ATEX APPROVED



SAFETY BONDING

MATERIALS

- BODY: ALUMINIUM
- NUTATING DISK CHAMBER: TECHNOPYLIMER

TECHNICAL DATA

CODE	DESCRIPTION	FLUIDS TYPE	FLOW DIRECTION	FLOW RATE		PRESSURE		INLET / OUTLET
				L/MIN	GPM	BAR	PSI	
FO057000A	K33 - ATEX VER. A	D G K	←	20 - 120	5 - 32	3,5	50	1" BSP
FO057001A	K33 - ATEX VER. B	D G K	↑	20 - 120	5 - 32	3,5	50	1" BSP
FO057002A	K33 - ATEX VER. C	D G K	↓	20 - 120	5 - 32	3,5	50	1" BSP
FO057003A	K33 - ATEX VER. D	D G K	→	20 - 120	5 - 32	3,5	50	1" BSP

FLUIDS PERMITTED: DIESEL, KEROSENE, PETROL, PETROL ALCOHOL MIXED MAX 20%, AVGAS 100/100LL (PUMP ONLY), JET A/A1 (PUMP ONLY) - ASPEN 2/4. UL CLASSIFIED VERSION AVAILABLE

K33 ATEX



FUEL MANAGEMENT SYSTEMS



DISPENSERS



KITS



PUMPS



METERS



NOZZLES

K150 ATEX



FEATURES

- HEAVY DUTY CONDITIONS
- HIGH FLOW RATE
- BURSTING PRESSURE 28 BAR
- EASY READING
- 4 FLOW DIRECTIONS

K150 ATEX is expressly engineered to meet the market requirements of a meter suitable for flow rates superior than 120 l/min and that can be used both for fluids such as diesel and biodiesel, as well as in potentially explosives atmosphere; with gasoline for example. K150 is easy to calibrate and ready to use; its aluminium cover and sturdy body make this meter suitable for a wide arrange of application while guaranteeing the same precision and quality that have always featured PIUSI equipment. The mechanical display allows to read quickly the quantity dispensed. It can be installed everywhere thanks to the (optional) 1,5" flange kit. K150 is certified CE, ATEX/UL and tested in PIUSI laboratories for over 4 milion litres to guarantee the maximum reliability.

PERFORMANCE

UP TO 150 L/MIN FLOW RATE	3,5 BAR MAX OPERATING PRESSURE
± 1% ACCURACY	0,3% REPEATABILITY



K150

PACKAGING

CODE	WEIGHT		PACKAGING			BOXES/EUROPALLET	
	KG	LBS	MM	INCH	PCS/BOX	✕	
FO055A00	2,38	5,25	185X185X170	7,28X7,28X6,69	1	192	240
FO055B00	2,38	5,25	185X185X170	7,28X7,28X6,69	1	192	240
FO055C00	2,38	5,25	185X185X170	7,28X7,28X6,69	1	192	240
FO055D00	2,38	5,25	185X185X170	7,28X7,28X6,69	1	192	240



FILTRATION



TANK MONITORING



HOSE REEL



ACCESSORIES



MERCHANDISE

INDEX



AIR



ANTIFREEZE



AdBlue®



BIODIESEL



DIESEL



FOOD



GASOLINE



GREASE



KEROSENE



OIL



WATER



WINDSCREEN

CHART



DIMENSIONS

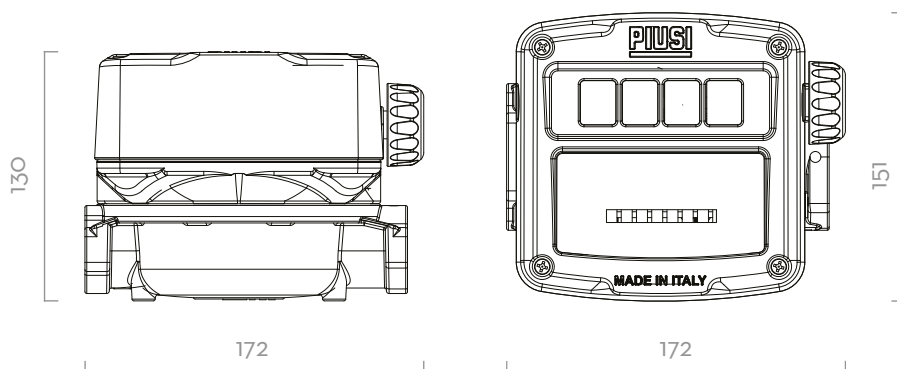

Dimensions expressed in millimeters

IN THE BOX

- K150 ATEX METER
- INSTRUCTION MANUAL

DETAILS



NUTATING DISK



4 FLOW DIRECTIONS



ATEX APPROVED



METALLIC COVER

MATERIALS

- BODY AND COVER: ALUMINIUM
- NUTATING DISK CHAMBER: TECHNOPYLIMER

TECHNICAL DATA

CODE	DESCRIPTION	FLUIDS TYPE	FLOW RATE		FLOW DIRECTIONS	PRESSURE		INLET/OUTLET
			L/MIN	GPM		BAR	PSI	
FO055A00	(EX) K150 METER VER.A ATEX	D G K	25-150	6,6-40	◀	3,5	50	1" BSP
FO055B00	(EX) K150 METER VER.B ATEX	D G K	25-150	6,6-40	▲	3,5	50	1" BSP
FO055C00	(EX) K150 METER VER.C ATEX	D G K	25-150	6,6-40	▼	3,5	50	1" BSP
FO055D00	(EX) K150 METER VER.D ATEX	D G K	25-150	6,6-40	▶	3,5	50	1" BSP

THE PIUSI K150 IS A MECHANICAL METER EXPRESSLY ENGINEERED FOR HEAVY DUTY AND HIGH FLOW RATE APPLICATIONS. IT IS EASY TO CALIBRATE AND READY-TO-USE; ITS ALUMINIUM COVER AND STURDY BODY MAKE THIS METER SUITABLE FOR A WIDE ARRANGE OF APPLICATIONS WHILE GUARANTEEING THE SAME PRECISION AND QUALITY THAT HAVE ALWAYS BEEN A FEATURE OF PIUSI EQUIPMENT.

K150 ATEX



FUEL MANAGEMENT SYSTEMS



DISPENSERS



KITS



PUMPS



METERS



NOZZLES

K24

FEATURES

- BURSTING PRESSURE 100 BAR
- LCD DISPLAY
- FLOW RATE INDICATION
- EASY TO CALIBRATE

The PIUSI K24 is a turbine digital flow meter specifically designed for diesel. Easy to install in-line or at the end of a delivery pipe, it is equipped with a rotatable display. This meter is available both with aluminium or technopolymer body.

PERFORMANCE

7-120

L/MIN

FLOW RATE

20 BAR

MAX

OPERATING PRESSURE

± 1%

ACCURACY

0,2%

REPEATABILITY



K24 plastic version



K24 PULSER

K24

PACKAGING

CODE	WEIGHT		PACKAGING		
	KG	LBS	MM	INCH	PCS/BOX
K24					
FOO40700A	0,5	1,1	BLISTER	BLISTER	1
FOO408100	0,5	1,1	BLISTER	BLISTER	1
K24 PULSER					
FOO40722A	0,5	1,1	115X160X135	4,5X6,3X5,3	1



FILTRATION



TANK MONITORING



HOSE REEL



ACCESSORIES



MERCHANDISE

INDEX



AIR



ANTIFREEZE



AdBlue®



BIODIESEL



DIESEL



FOOD



GASOLINE



GREASE



KEROSENE



OIL



WATER



WINDSCREEN

CHART

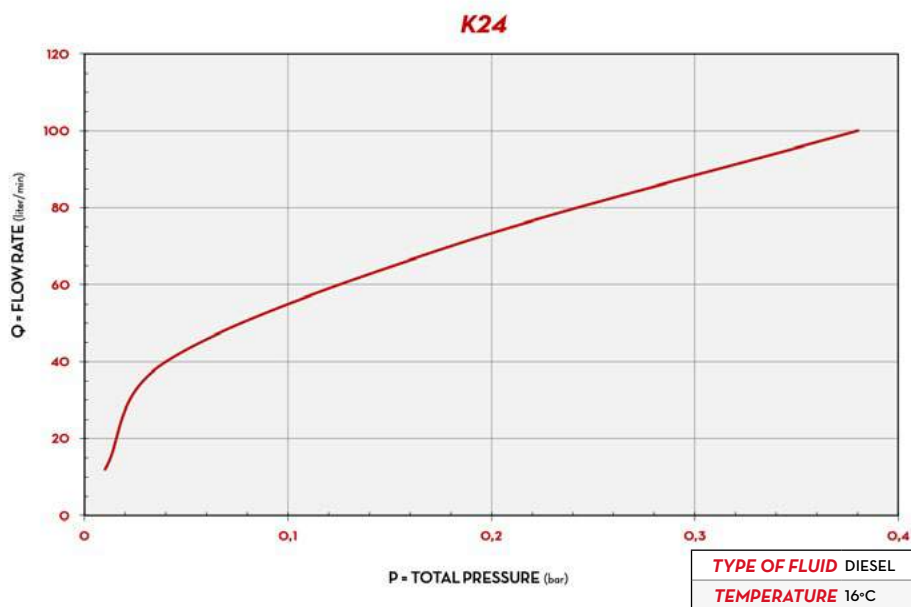

DIMENSIONS

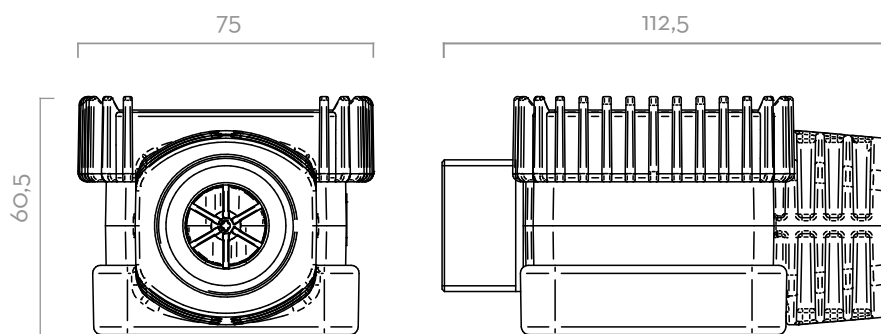

Dimensions expressed in millimeters

IN THE BOX

- K24 METER
- SOCKET F/F
- INSTRUCTION MANUAL

DETAILS



MATERIALS

- BODY: ALUMINIUM
- GEARS: TECHNOPOLYMER

TECHNICAL DATA

CODE	DESCRIPTION	FLUIDS TYPE	FLOW RATE		PRESSURE		BATTERY	FLANGE	INLET / OUTLET
			L/MIN	GPM	BAR	PSI	2X AAA BATTERY 1,5V (INCLUDED)		
K24									
FOO40700A	K24 METER M/MF LITER BLACK 1INBSP	D	7 - 120	2 - 32	10	150	YES	NO	M 1" BSP - M 1" BSP
FOO408100	K24 M/F 1" BSP	D	7 - 120	2 - 32	20	300	YES	NO	M 1" BSP - F 1" BSP
K24 PULSER									
FOO40722A	K24 PULSER M/MF LITER BLACK 1INBSP	D	7 - 120	2 - 32	10	150	NO	NO	M 1" BSP - M 1" BSP

UPON REQUEST AVAILABLE IN NPTF VERSION AND DISPLAY IN GALLON/QUARTER OR PRINT
N° 2X1,5V BATTERY INCLUDED

K24



FUEL MANAGEMENT SYSTEMS



DISPENSERS



KITS



PUMPS



METERS



NOZZLES

K600/3

FEATURES

- ADJUSTABLE FLANGES
- SUITABLE FOR INDUSTRIAL APPLICATIONS
- IDEAL FOR MOBILE INSTALLATIONS
- LOW ENERGY CONSUMPTIONS

The PIUSI K600/3 is an oval gear meter suitable for monitoring the delivery of diesel, oil and antifreeze. The meter is equipped with an integrated filter and is also available in pulser version.

PERFORMANCE

UP TO 100 L/MIN	30 BAR MAX
FLOW RATE	OPERATING PRESSURE
± 0,5%	0,2%
ACCURACY	REPEATABILITY



K600/3 METER



K600/3 PULSER

PACKAGING

CODE	WEIGHT		PACKAGING		
	KG	LBS	MM	INCH	PCS/BOX
METER					
FOO496A00	1,6	3,5	200X120X140	7,9X4,7X5,5	1
PULSER					
FOO472A00	2,6	5,7	200X120X140	7,9X4,7X5,5	1



FILTRATION



TANK MONITORING



HOSE REEL



ACCESSORIES



MERCHANDISE

INDEX



AIR



ANTIFREEZE



AdBlue®



BIODIESEL



DIESEL



FOOD



GASOLINE



GREASE



KEROSENE



OIL



WATER



WINDSCREEN

CHART

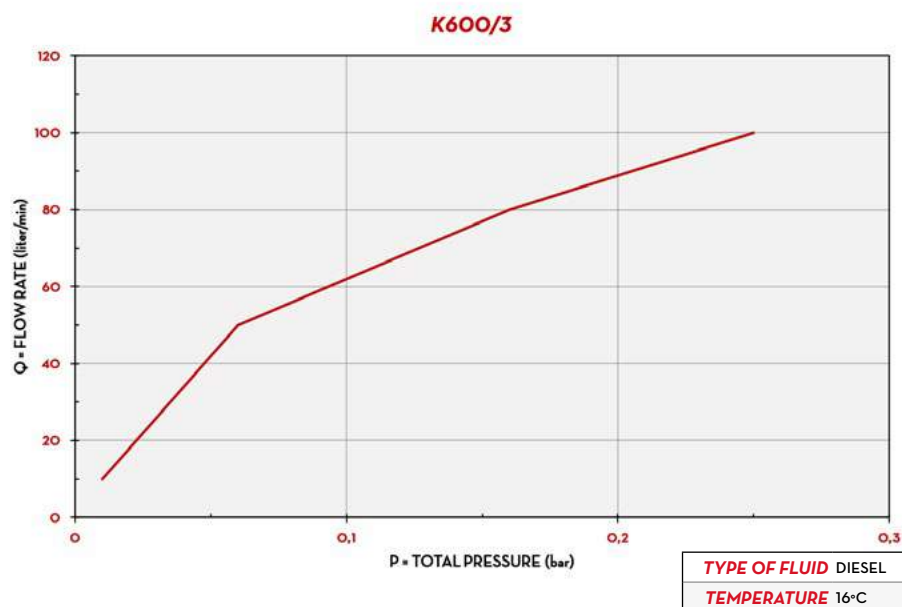

IN THE BOX

- K600/3 METER
- FLANGES
- INSTRUCTION MANUAL

DETAILS



DIMENSIONS

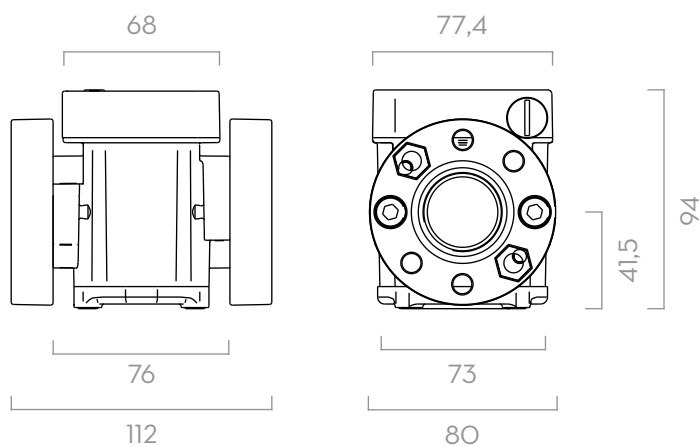

Dimensions expressed in millimeters

MATERIALS

- BODY: ALUMINIUM
- GEARS: TECHNOPOLYMER

TECHNICAL DATA

CODE	DESCRIPTION	FLUIDS TYPE	FLOW RATE		PRESSURE		BATTERY	FLANGE	INLET / OUTLET	INLET FILTER
			L/MIN	GPM	BAR	PSI	N°2 X 1,5V (INCLUDED)			
METER										
FOO496A00	K600/3 DIESEL	A D O	10 - 100	2,64 - 26,4	30	426	YES	YES	1" BSP	YES
PULSER										
FOO472A00	K600/3 1" DIESEL	A D O	10 - 100	2,64 - 26,4	30	426	NO	YES	1" BSP	YES

UPON REQUEST AVAILABLE IN NPTF VERSION AND DISPLAY IN GALLON/QUARTER OR PRINT

K600/3



FUEL MANAGEMENT SYSTEMS



DISPENSERS



KITS



PUMPS



METERS



NOZZLES

K600 B/3

FEATURES

- BETTER VISIBILITY
- ADJUSTABLE FLANGES
- ROTATING DISPLAY
- STANDARD BATTERY
- PULSE-OUT VERSION AVAILABLE
- IP66

The PIUSI K600 B/3 is an oval gear meter suitable for monitoring the delivery of diesel, biodiesel and antifreeze. This special version includes a large 80mm built-in digital display that can be rotated to suit every application. Among its features: 5-digit partial total and resettable total. Pulser version available.

PERFORMANCE

UP TO
100 L/MIN

FLOW RATE

30 BAR
MAX

OPERATING PRESSURE

± 0,5%

ACCURACY

0,2%

REPEATABILITY



K600 B/3 METER



K600 B/3 WITH PULSE-OUT

PACKAGING

CODE	WEIGHT		PACKAGING		
	KG	LBS	MM	INCH	PCS/BOX
METER					
FOO491000	2	4,4	200X120X140	7,9X4,7X5,5	1
PULSER					
FOO492000	2	4,4	200X120X140	7,9X4,7X5,5	1



FILTRATION



TANK MONITORING



HOSE REEL



ACCESSORIES



MERCHANDISE

INDEX



AIR



ANTIFREEZE



AdBlue®



BIODIESEL



DIESEL



FOOD



GASOLINE



GREASE



KEROSENE



OIL



WATER



WINDSCREEN

CHART



DIMENSIONS

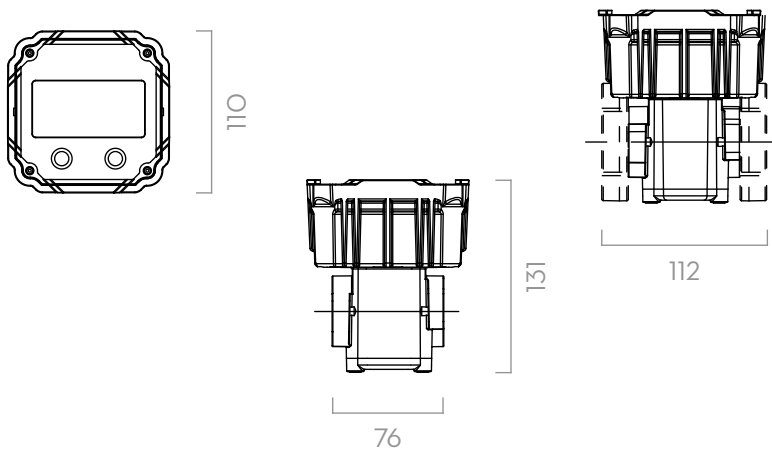

Dimensions expressed in millimeters

IN THE BOX

- K600 B/3 METER
- FLANGES
- INSTRUCTION MANUAL

DETAILS



MATERIALS

- BODY: ALUMINIUM
- GEARS: TECHNOPOLYMER

TECHNICAL DATA

CODE	DESCRIPTION	FLUIDS TYPE	FLOW RATE		PRESSURE		BATTERY N°2 X 1,5V (INCLUDED)	FLANGE	INLET / OUTLET	INLET FILTER
			L/MIN	GPM	BAR	PSI				
METER										
FO0491000	K600 B/3	D	10 - 100	2,64 - 26,4	30	426	YES	YES	1" BSP	YES
PULSER										
FO0492000	K600 B/3 WITH PULSE-OUT	D	10 - 100	2,64 - 26,4	30	426	YES	YES	1" BSP	YES

UPON REQUEST AVAILABLE IN NPTF VERSION AND DISPLAY IN GALLON/QUARTER OR PRINT

K600 B/3



FUEL MANAGEMENT SYSTEMS



DISPENSERS



KITS



PUMPS



METERS



NOZZLES

K600/4

FEATURES

- EASY TO INSTALL AND TO CALIBRATE
- VERSATILE
- HIGH PRECISION

The PIUSI K600/4 is an oval gear meter suitable for monitoring the delivery of fuels. This special version is particularly suitable for all applications in the industrial sector.

PERFORMANCE

15-150

L/MIN

FLOW RATE

20 BAR

MAX

OPERATING PRESSURE

± 0,5%

ACCURACY

0,2%

REPEATABILITY



K600/4



K600/4 PULSER

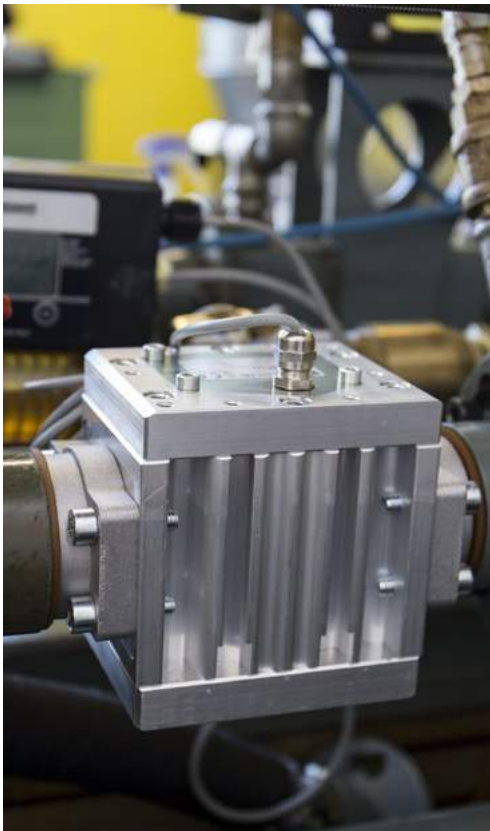

PACKAGING

CODE	WEIGHT		PACKAGING		
	KG	LBS	MM	INCH	PCS/BOX
METER					
00049700A	3,2	7	200X120X140	7,9X4,7X5,5	1
PULSER					
000473000	3,2	7	200X120X140	7,9X4,7X5,5	1



FILTRATION



TANK MONITORING



HOSE REEL



ACCESSORIES



MERCHANDISE

INDEX



AIR



ANTIFREEZE



AdBlue®



BIODIESEL



DIESEL



FOOD



GASOLINE



GREASE



KEROSENE



OIL



WATER



WINDSCREEN

CHART

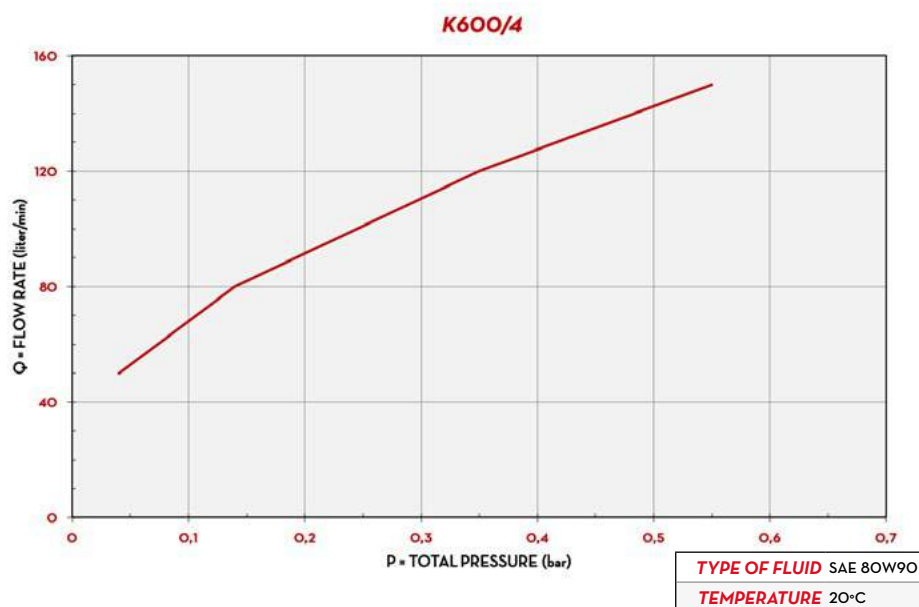

IN THE BOX

- K600/4 METER
- FLANGES
- INSTRUCTION MANUAL

DETAILS



DIMENSIONS

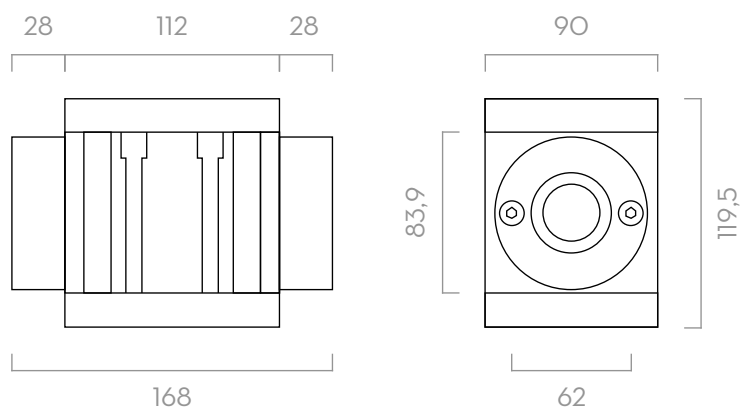

Dimensions expressed in millimeters

MATERIALS

- BODY: ALUMINIUM
- GEARS: TECHNOPOLYMER

TECHNICAL DATA

CODE	DESCRIPTION	FLUIDS TYPE	FLOW RATE		PULSER		PRESSURE		BATTERY N°2 X 1,5V (INCLUDED)	FLANGE	INLET / OUTLET	INLET FILTER
			L/MIN	GPM	P/L	GPM	BAR	PSI				
00049700A	K600/4	A B D O	15 - 150	3,9 - 39	-	-	20	284	YES	YES	1 1/2" BSP	YES
000473000	K600/4 PULSER	A B D O	15 - 150	3,9 - 39	26	98	20	300	NO	YES	1 1/2"	YES

UPON REQUEST AVAILABLE IN NPT VERSION.

K600/4



FUEL MANAGEMENT SYSTEMS



DISPENSERS



KITS



PUMPS



METERS



NOZZLES

K700 PULSER

FEATURES

- EASY TO INSTALL AND TO CALIBRATE
- VERSATILE
- HIGH FLOW RATE
- HEAVY DUTY
- INDUSTRIAL APPLICATIONS

The PIUSI K700 PULSER is an oval gear electronic meter with acetal resin gears. This pulse meter easily interfaces with management systems, making it the ideal solution to fit fuel distributors. It is also suitable for tanks and cisterns, loading arms controlling the consumption of fuel in burners or generator sets, besides other applications.

PERFORMANCE

25-250

L/MIN

FLOW RATE

20 BAR

MAX

OPERATING PRESSURE

± 0,5%

ACCURACY

0,2%

REPEATABILITY



K700 PULSER



PACKAGING

CODE	WEIGHT		PACKAGING		
	KG	LBS	MM	INCH	PCS/BOX

PULSER

FOO49800A	5,5	12	280X160X140	11X6,3X5,5	1
-----------	-----	----	-------------	------------	---



FILTRATION



TANK MONITORING



HOSE REEL



ACCESSORIES



MERCHANDISE

INDEX



AIR



ANTIFREEZE



AdBlue®



BIODIESEL



DIESEL



FOOD



GASOLINE



GREASE



KEROSENE



OIL



WATER



WINDSCREEN

CHART



IN THE BOX

- K700 PULSER METER
- INSTRUCTION MANUAL

DETAILS



DIMENSIONS

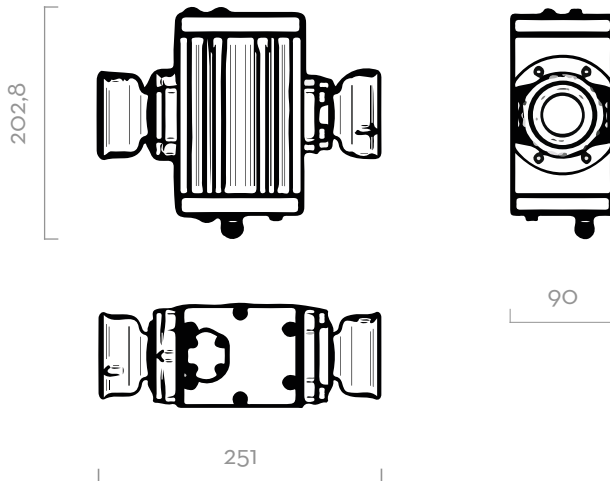

Dimensions expressed in millimeters

MATERIALS

- BODY: ALUMINIUM
- GEARS: TECHNOPOLYMER

TECHNICAL DATA

CODE	DESCRIPTION	FLUIDS TYPE	FLOW RATE		PULSER		PRESSURE		BATTERY N°2 X 1,5V (INCLUDED)	FLANGE	INLET / OUTLET	INLET FILTER
			L/MIN	GPM	P/L	GPM	BAR	PSI				
FOO49800A	K700 PULSER	A B D O	25 - 250	6,6 - 66	14	53	20	300	NO	YES	2" BSP	YES

PULSER

UPON REQUEST AVAILABLE IN NPT VERSION.

K700 PULSER



FUEL MANAGEMENT SYSTEMS



DISPENSERS



KITS



PUMPS



METERS



NOZZLES

K900

FEATURES

- STURDY STRUCTURE
- HEAVY DUTY CONDITIONS
- HIGH FLOW RATE APPLICATIONS
- READY TO INSTALL

Among the electronic flow meters Made in Italy by PIUSI, the K900 is the oval gear measuring equipment suitable for controlling the non commercial dispensing of low, medium and high viscosity fluids compatible with its construction materials. This meter is equipped with an in-built suction filter, 3" inlet/outlet and free contact signal pulser.

PERFORMANCE

50-500

L/MIN

FLOW RATE

20 BAR

MAX

OPERATING PRESSURE

±0,5%

ACCURACY

0,2%

REPEATABILITY



K900



PACKAGING

CODE	WEIGHT		PACKAGING		
	KG	LBS	MM	INCH	PCS/BOX
METER FOO49900B	12	26,5	400X290X200	15,7X11,4X7,9	1
PULSER FOO49902B	12	26,5	400X290X200	15,7X11,4X7,9	1



FILTRATION



TANK MONITORING



HOSE REEL



ACCESSORIES



MERCHANDISE

INDEX



AIR



ANTIFREEZE



AdBlue®



BIODIESEL



DIESEL



FOOD



GASOLINE



GREASE



KEROSENE



OIL



WATER



WINDSCREEN

CHART



DIMENSIONS

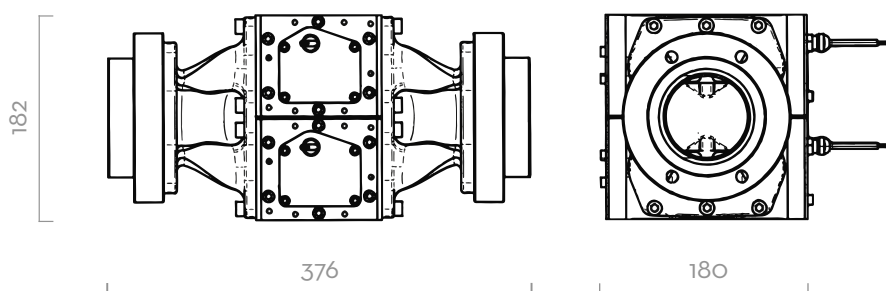

Dimensions expressed in millimeters

IN THE BOX

- K900 METER
- INSTRUCTION MANUAL

DETAILS



MATERIALS

- BODY: ALUMINIUM
- GEARS: TECHNOPOLYMER

TECHNICAL DATA

CODE	DESCRIPTION	FLUIDS TYPE	FLOW RATE		PULSER		PRESSURE		BATTERY N°2 X 1,5V (INCLUDED)	FLANGE	INLET / OUTLET	INLET FILTER
			L/MIN	GPM	P/L	GPM	BAR	PSI				
FOO49900B	K900	B D	50 - 500	13,2 - 132	-	-	20	284	YES	YES	3" BSP	YES
FOO49902B	K900 PULSER	B D	50 - 500	13,2 - 132	10	38	20	284	YES	YES	3" BSP	YES

UPON REQUEST AVAILABLE IN NPT VERSION. DISPLAY POWER SUPPLY 4-12VDC, 1,2 AMP. TYPE OF OUTPUT SIGNAL: OPEN COLLECTOR MAX 50V, 1,2 AMP, SINGLE CHANNEL.

K900



FUEL MANAGEMENT SYSTEMS



DISPENSERS



KITS



PUMPS



METERS



NOZZLES

REMOTE DISPLAY

FEATURES

- LARGE SCREEN DISPLAY
- NON RESETTABLE TOTAL
- STANDARD BATTERY

REMOTE DISPLAY for remote control (via max. 15 m. cable) of pulse meters. The large screen displays the quantity delivered and the non resettable total. Equipped with software applications for calibrating meters. Available as both basic display device and as pulse emitter. Indispensable for receivers designed to recognise only discreet quantities of impulses. The easy interfacing management systems of the pulse transmitter models extend the field of application of pulse meters combined with remote displays.

PERFORMANCE

every

PULSE METER

COMPATIBILITY

UP TO

100

PULSES/LITER

FLOW RATE



REMOTE DISPLAY



PACKAGING

CODE	WEIGHT		PACKAGING		
	KG	LBS	MM	INCH	PCS/BOX
F1175200B	1,2	2,6	200X120X140	7,9X4,7X5,5	1
F1175300B	1,2	2,6	200X120X140	8,9X4,9X5,9	1
F1175400B	1,2	2,6	200X120X140	8,9X4,9X5,9	1
FOO49501A	1,2	2,6	200X120X140	8,9X4,9X5,9	1
FOO49502A	1,2	2,6	200X120X140	8,9X4,9X5,9	1
FOO49503B	1,2	2,6	225X125X150	8,9X4,9X5,9	1



FILTRATION



TANK MONITORING



HOSE REEL



ACCESSORIES



MERCHANDISE

INDEX



AIR



ANTIFREEZE



AdBlue®



BIODIESEL



DIESEL



FOOD



GASOLINE



GREASE



KEROSENE



OIL



WATER



WINDSCREEN

CHART

Remote display battery powered

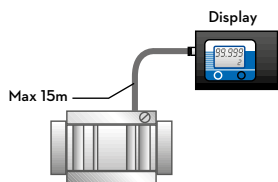

Remote display battery powered

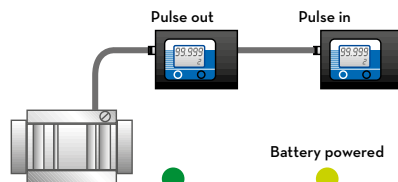

Display pulse transmitter battery powered

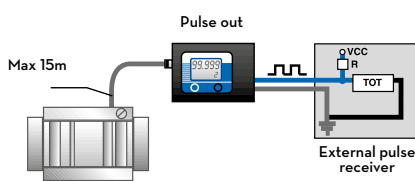

Display pulse transmitter externally powered

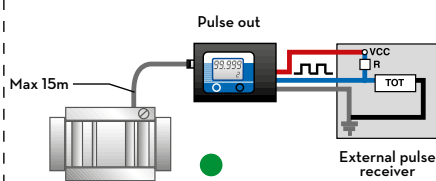

IN THE BOX

- REMOTE DISPLAY UNIT
- BRACKET
- INSTRUCTION MANUAL

DETAILS



5 DIGITS PARTIAL TOTAL

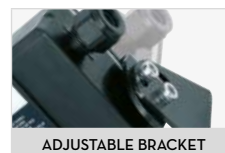

ADJUSTABLE BRACKET

DIMENSIONS

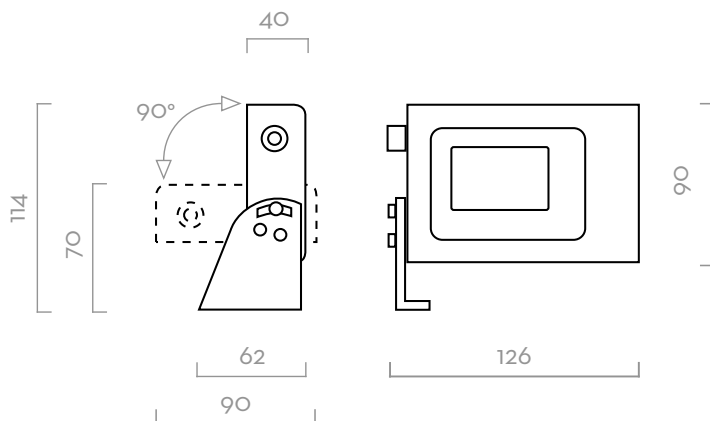

Dimensions expressed in millimeters

TECHNICAL DATA

CODE	DESCRIPTION	FLUIDS TYPE	FLANGE	INLET OUTLET
F1175200B	REMOTE DISPLAY PULSE OUT K600	Ad B D O W W	K600 DIESEL	PULSE OUT ●
F1175300B	REMOTE DISPLAY PULSE OUT K600/4	Ad B D O W W	K600/4	PULSE OUT ●
F1175400B	REMOTE DISPLAY PULSE OUT K700	Ad B D O W W	K700	PULSE OUT ●
FO049501A	REMOTE DISPLAY PULSE OUT UNIVERSAL	Ad B D O W W	K200, K400, K600 OIL, K600 DIESEL, K600/4, K700	PULSE OUT ●
FO049502A	UNIVERSAL REMOTE DISPLAY PULSE IN	Ad B D O W W	FOR ALL PIUSI PULSE OUT REMOTE DISPLAY	PULSE IN ●
FO049503B	REMOTE DISPLAY PULSE OUT 100 ADBLUE	Ad B D O W W	TURBINOX / K24 PULSER	PULSE OUT ●

REMOTE DISPLAY



FUEL MANAGEMENT SYSTEMS



DISPENSERS



KITS



PUMPS



METERS



NOZZLES

K33 / K44

FEATURES

- **READY TO USE**
- **BURSTING PRESSURE 30 BAR**
- **NO BATTERY NEEDED**
- **EASY TO INSTALL AND CALIBRATE**
- **4 FLOW DIRECTION**

The PIUSI K33 and K44 are the bestseller mechanical meters in this market. Reliable, easy to install and to calibrate, they are equipped with a nutating disk that allows them to be installed in all four flow directions. The display is available in both three or four digits, according to the model chosen.

PERFORMANCE

20-120

L/MIN

FLOW RATE

3,5 BAR

MAX OPERATING

PRESSURE

±1%

ACCURACY

±0,3%

REPEATIBILITY



PACKAGING

CODE	WEIGHT		PACKAGING			N. BOXES / EUROPALLET	
	KG	LBS	MM	INCH	PCS/BOX	✕	🚚
METERS							
000550000	0,6	1,3	180X180X170	-	1	192	240
000551000	0,6	1,3	180X180X170	-	1	192	240
000552000	0,6	1,3	180X180X170	-	1	192	240
000553000	0,6	1,3	180X180X170	-	1	192	240
000560000	0,6	1,3	180X180X170	-	1	192	240
000561000	0,6	1,3	180X180X170	-	1	192	240
000562000	0,6	1,3	180X180X170	-	1	192	240
000563000	0,6	1,3	180X180X170	-	1	192	240
PULSER							
00056500A	0,6	1,3	180X180X170	-	1	192	240



FILTRATION



TANK MONITORING



HOSE REEL



ACCESSORIES



MERCHANDISE

INDEX



AIR



ANTIFREEZE



AdBlue®



BIODIESEL



DIESEL



FOOD



GASOLINE



GREASE



KEROSENE



OIL



WATER



WINDSCREEN

CHART

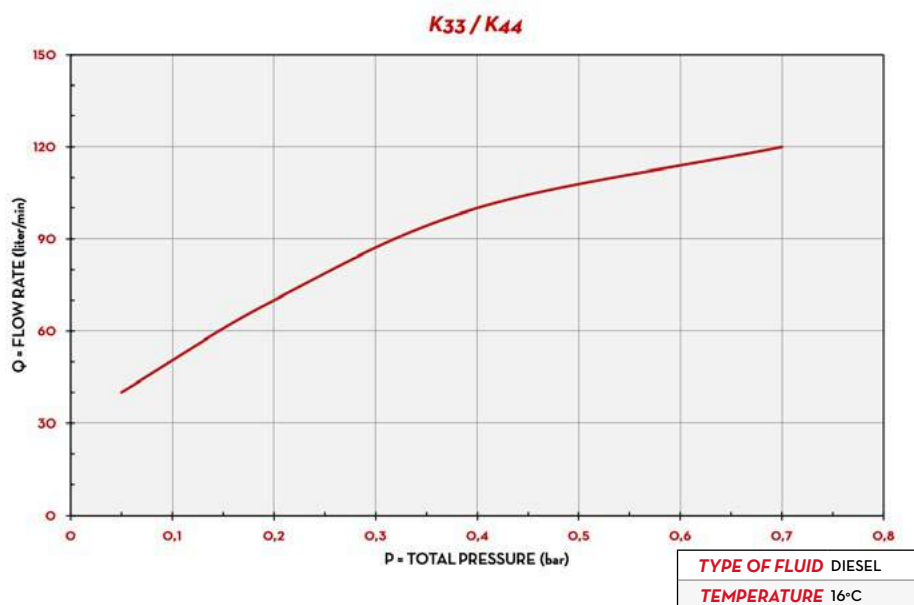

IN THE BOX

- K33 / K44 METER
- INSTRUCTION MANUAL

DETAILS



NUTATING DISK SYSTEM



4 FLOW DIRECTIONS

DIMENSIONS

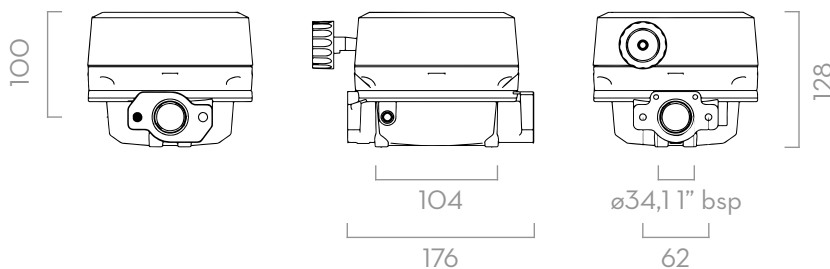

Dimensions expressed in millimeters

MATERIALS

- BODY: ALUMINIUM
- NUTATING DISK CHAMBER: TECHNOPYLIMER

TECHNICAL DATA

CODE	DESCRIPTION	FLUIDS TYPE	FLOW DIRECTION	FLOW RATE		PRESSURE		PULSER P/L (P/GAL)	INLET / OUTLET
				L/MIN	GPM	BAR	PSI		
METERS									
000550000	K33 VER. A	D	←	20 - 120	5 - 32	10	142	-	1" BSP
000551000	K33 VER. B	D	↕	20 - 120	5 - 32	10	142	-	1" BSP
000552000	K33 VER. C	D	↕	20 - 120	5 - 32	10	142	-	1" BSP
000553000	K33 VER. D	D	→	20 - 120	5 - 32	10	142	-	1" BSP
000560000	K44 VER. A	D	←	20 - 120	5 - 32	10	142	-	1" BSP
000561000	K44 VER. B	D	↕	20 - 120	5 - 32	10	142	-	1" BSP
000562000	K44 VER. C	D	↕	20 - 120	5 - 32	10	142	-	1" BSP
000563000	K44 VER. D	D	→	20 - 120	5 - 32	10	142	-	1" BSP
PULSER									
00056500A	K44 PULSER	D	→	20 - 120	5 - 32	10	142	10 (38)	1" BSP

K33 / K44



FUEL MANAGEMENT SYSTEMS



DISPENSERS



KITS



PUMPS



METERS



NOZZLES

K150

FEATURES

- HEAVY DUTY CONDITIONS
- HIGH FLOW RATE
- BURSTING PRESSURE 28 BAR
- EASY READING
- 4 FLOW DIRECTIONS

K150 is expressly engineered to meet the market requirements of a meter suitable for flow rates superior than 120 l/min and that can be used both for fluids such as diesel and biodiesel, as well as in potentially explosives atmosphere; with gasoline for example. K150 is easy to calibrate and ready to use; its aluminium cover and sturdy body make this meter suitable for a wide arrange of application while guaranteeing the same precision and quality that have always featured PIUSI equipment. The mechanical display allows to read quickly the quantity dispensed. It can be installed everywhere thanks to the (optional) 1,5" flange kit.

PERFORMANCE

UP TO

150

L/MIN

FLOW RATE

3,5 BAR

MAX

OPERATING PRESSURE

± 1%

ACCURACY

0,3%

REPEATABILITY



K150



PACKAGING

CODE	WEIGHT		PACKAGING			BOXES/EUROPALLET	
	KG	LBS	MM	INCH	PCS/BOX	✕	
FO0554A00	2,38	5,25	185X185X170	7,28X7,28X6,69	1	192	240
FO0554B00	2,38	5,25	185X185X170	7,28X7,28X6,69	1	192	240
FO0554C00	2,38	5,25	185X185X170	7,28X7,28X6,69	1	192	240
FO0554D00	2,38	5,25	185X185X170	7,28X7,28X6,69	1	192	240



FILTRATION



TANK MONITORING



HOSE REEL



ACCESSORIES



MERCHANDISE

INDEX



AIR



ANTIFREEZE



AdBlue®



BIODIESEL



DIESEL



FOOD



GASOLINE



GREASE



KEROSENE



OIL



WATER



WINDSCREEN

CHART

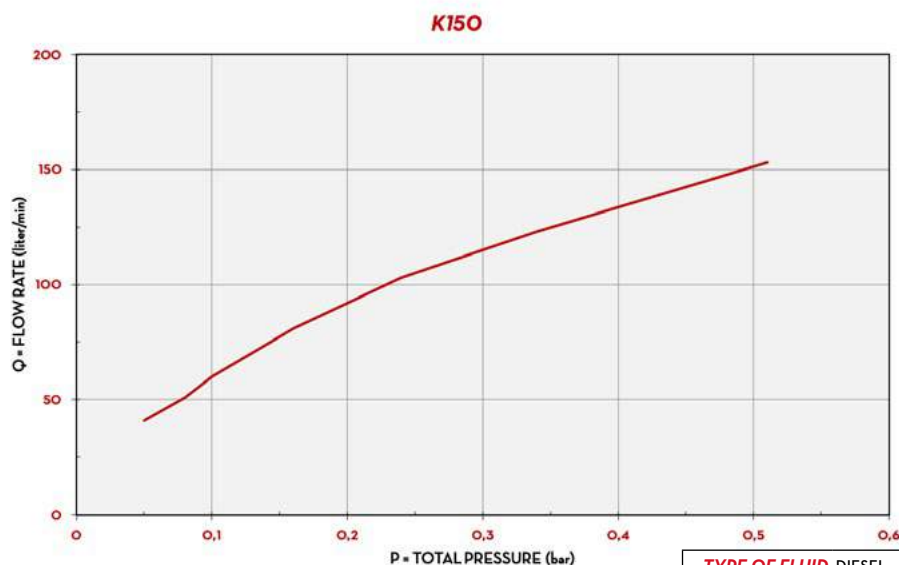

TYPE OF FLUID DIESEL
TEMPERATURE 16°C

DIMENSIONS

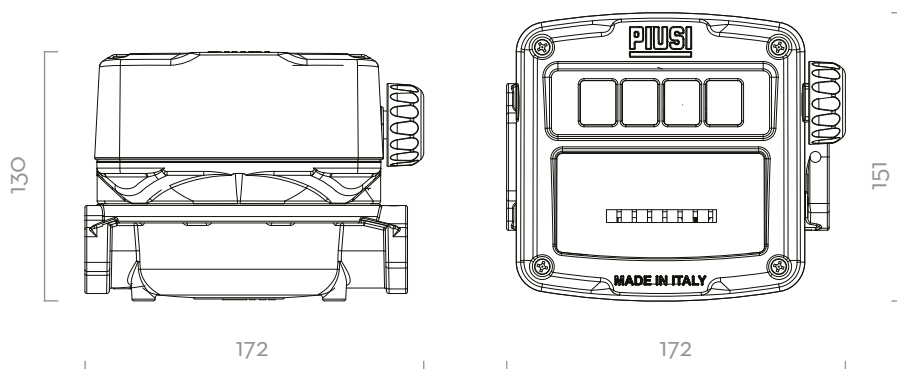

Dimensions expressed in millimeters

IN THE BOX

- K150 METER
- INSTRUCTION MANUAL

DETAILS



NUTATING DISK



4 FLOW DIRECTIONS



METALLIC COVER

MATERIALS

- BODY AND COVER: ALUMINIUM
- NUTATING DISK CHAMBER: TECHNOPYLIMER

TECHNICAL DATA

CODE	DESCRIPTION	FLUIDS TYPE	FLOW RATE		FLOW DIRECTIONS	PRESSURE		INLET/OUTLET
			L/MIN	GPM		BAR	PSI	
FO0554A00	K150 METER LITERS - 1" BSP VER.A	D	25-150	6,6-40	◀	3,5	50	1" BSP
FO0554B00	K150 METER LITERS - 1" BSP VER.B	D	25-150	6,6-40	▲	3,5	50	1" BSP
FO0554C00	K150 METER LITERS - 1" BSP VER.C	D	25-150	6,6-40	▼	3,5	50	1" BSP
FO0554D00	K150 METER LITERS - 1" BSP VER.D	D	25-150	6,6-40	▶	3,5	50	1" BSP

THE PIUSI K150 IS A MECHANICAL METER EXPRESSLY ENGINEERED FOR HEAVY DUTY AND HIGH FLOW RATE APPLICATIONS. IT IS EASY TO CALIBRATE AND READY-TO-USE; ITS ALUMINIUM COVER AND STURDY BODY MAKE THIS METER SUITABLE FOR A WIDE ARRANGE OF APPLICATIONS WHILE GUARANTEEING THE SAME PRECISION AND QUALITY THAT HAVE ALWAYS BEEN A FEATURE OF PIUSI EQUIPMENT.

K150



FUEL MANAGEMENT SYSTEMS



DISPENSERS



KITS



PUMPS



METERS



NOZZLES

K700

FEATURES

- HEAVY DUTY CONDITIONS
- STURDY STRUCTURE
- BURSTING PRESSURE 30 BAR
- NO BATTERY NEEDED
- EASY TO INSTALL
- 2 FLOW DIRECTION

Medium-high flow rates require specific measuring equipment able to adapt precisely to the flow: It is the case of the oval gear mechanical flow meter PIUSI K700: a sturdy, reliable and easy to install equipment suitable for the most demanding environments. The meter displays 4-digit piece of equipment partial total that can show up to a maximum of 9999 liters.

PERFORMANCE

40-220

L/MIN

FLOW RATE

10 BAR

MAX OPERATING

PRESSURE

± 1,5%

ACCURACY

0,3%

REPEATABILITY



K700



PACKAGING

CODE	WEIGHT		PACKAGING			N. BOXES / EUROPALLET	
	KG	LBS	MM	INCH	PCS/BOX		
FO0540000	5,8	12,8	240X240X275	-	1	48	72
FO0540020	5,8	12,8	240X240X275	-	1	48	72
FO0540030	5,8	12,8	240X240X275	-	1	48	72
FO0540040	5,8	12,8	240X240X275	-	1	48	72



FILTRATION



TANK MONITORING



HOSE REEL



ACCESSORIES



MERCHANDISE

INDEX



AIR



ANTIFREEZE



AdBlue®



BIODIESEL



DIESEL



FOOD



GASOLINE



GREASE



KEROSENE



OIL



WATER



WINDSCREEN

CHART

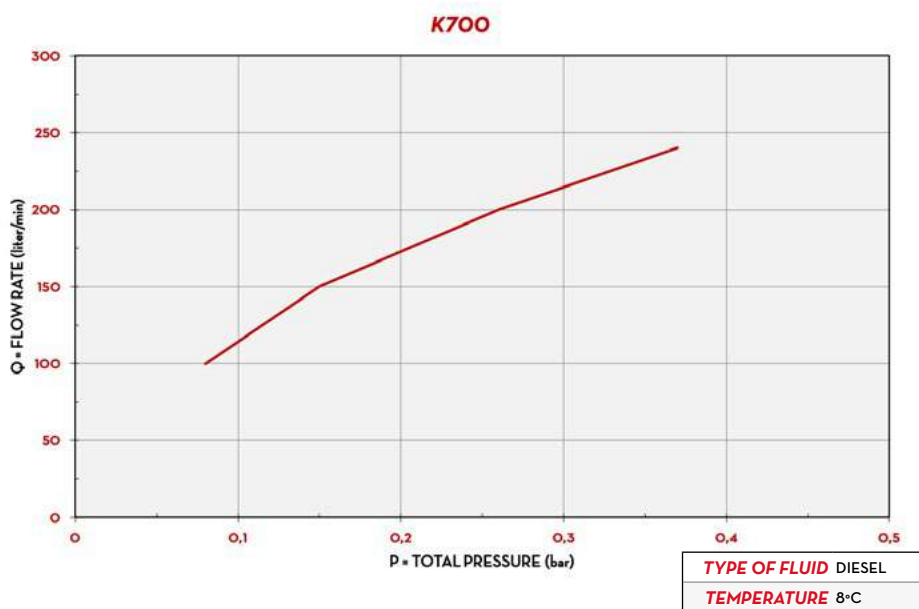

DIMENSIONS

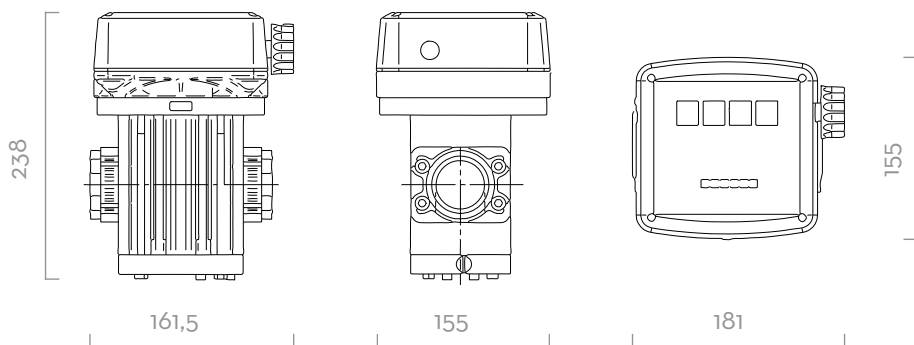

Dimensions expressed in millimeters

IN THE BOX

- K700 METER
- INSTRUCTION MANUAL

DETAILS



MATERIALS

- BODY: ALUMINIUM
- GEARS: TECHNOPOLYMER

TECHNICAL DATA

CODE	DESCRIPTION	FLUIDS TYPE	FLOW DIRECTION	FLOW RATE		PRESSURE		INLET FILTER	INLET / OUTLET
				L/MIN	GPM	BAR	PSI		
FO0540000	K700 VER. A	D	◀	40 - 220	5 - 53	10	142	YES	1" 1/2 BSP
FO0540020	K700 VER. B	D	▲	40 - 220	5 - 32	10	142	YES	1" 1/2 BSP
FO0540030	K700 VER. C	D	▼	40 - 220	5 - 53	10	142	YES	1" 1/2 BSP
FO0540040	K700 VER. D	D	▶	40 - 220	5 - 32	10	142	YES	1" 1/2 BSP

K700

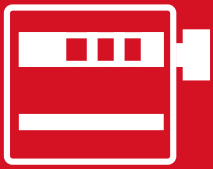



METERS ACCESSORIES

ELECTRONIC METERS

K24	CODE	DESCRIPTION
	FOO49501A	REMOTE DISPLAY PULS OUT UNIVERSAL
	FOO49502A	UNIVERSAL REMOTE DISPLAY PULS IN



FOO49501A
FOO49502A

K600/3 PULSER	CODE	DESCRIPTION
	FOO49501A	DISPLAY REMOTO PULS OUT UNIVERSALE
	FOO49502A	DISPLAY REMOTO PULS IN UNIVERSALE



FOO49501A
FOO49502A

K600/3 METER	CODE	DESCRIPTION
	F1175200B	REMOTE DISPLAY PULS OUT K600/3 LT SEL



F1175200B

K600/4	CODE	DESCRIPTION
	FOO49501A	REMOTE DISPLAY PULS OUT UNIVERSAL
	FOO49502A	UNIVERSAL REMOTE DISPLAY PULS IN
	F1175300B	REMOTE DISPLAY PULS OUT K600/4 LT SEL

FOO49501A
FOO49502A
F1175300B

K700	CODE	DESCRIPTION
	FOO49501A	REMOTE DISPLAY PULS OUT UNIVERSAL
	FOO49502A	UNIVERSAL REMOTE DISPLAY PULS IN
	F1175400B	REMOTE DISPLAY PULS OUT K700 LT SEL

FOO49501A
FOO49502A
F1175400B

K900	CODE	DESCRIPTION
	RT152600A	KIT DR K900 W PULS OUT
	RT146400A	KIT DR K900 W/O PULS OUT

RT152600A
RT146400A





NOZZLES

A large, solid red triangle is positioned in the bottom right corner of the page, pointing towards the top right.



FUEL MANAGEMENT SYSTEMS



DISPENSERS



KITS



PUMPS



METERS



NOZZLES

A60 / A140 ATEX

FEATURES

- AUTOMATIC
- READY TO USE
- STURDY DESIGN

Expressly engineered to meet the strictest requirements of the ATEX/IECEX regulations, the PIUSI A60/A140 ATEX is an automatic nozzle suitable to dispense fluids - such as gasoline, kerosene, diesel and others - in potentially explosive atmospheres. It is fitted with a structural component that automatically stops dispensing when the tank is full.

PERFORMANCE

UP TO 140 L/MIN	1" BSP
FLOW RATE	INLET
A60 Ø24MM	A140 Ø29MM
SPOUT	SPOUT



A60 ATEX



A140 ATEX

PACKAGING

CODE		WEIGHT		PACKAGING			BOXES/EUROPALLET	
WITHOUT SWIVEL	WITH SWIVEL	KG	LBS	MM	INCH	PCS/BOX		
A60 ATEX								
-	F00613020	1,25	2,76	460X200X80	181X78X31	1	-	-
A140 ATEX								
F22675000	-	2,00	4,41	460X200X80	181X78X31	1	-	-



FILTRATION



TANK MONITORING



HOSE REEL



ACCESSORIES



MERCHANDISE

INDEX



AIR



ANTIFREEZE



AdBlue®



BIODIESEL



DIESEL



FOOD



GASOLINE



GREASE



KEROSENE



OIL



WATER



WINDSCREEN

CHART

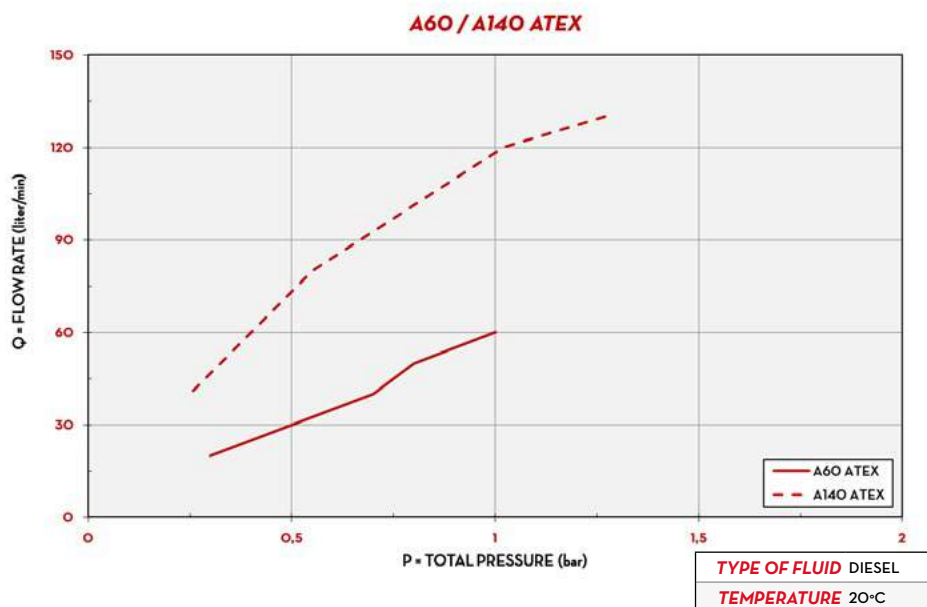

IN THE BOX

- A60 / A140 ATEX NOZZLE
- INSTRUCTION MANUAL

DETAILS



DIMENSIONS

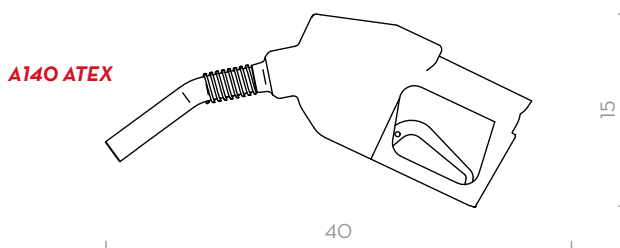
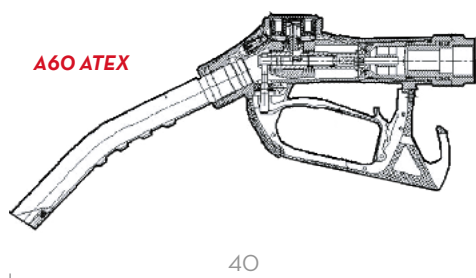

Dimensions expressed in millimeters

MATERIALS

- BODY: ALUMINIUM
- SEAL: NBR

TECHNICAL DATA

CODE		DESCRIPTION	FLUIDS TYPE	FLOW RATE		INLET		SPOUT
WITHOUT SWIVEL	WITH SWIVEL			L/MIN	GPM	WITHOUT SWIVEL BSP	WITH SWIVEL BSP	EXT. Ø MM
A60 ATEX								
-	FOO613020	A60 ATEX	D G K	60	16	-	F1"	24
A140 ATEX								
F22675000	-	(EX) AUTOMATIC NOZZLE A140 W/OUT SWIVEL	D G K	140	37	F1"	-	28,7

A60 / A140 ATEX



FUEL MANAGEMENT SYSTEMS



DISPENSERS



KITS



PUMPS



METERS



NOZZLES

A60 / A80 / A120 / A140

FEATURES

- AUTOMATIC
- READY TO USE
- STURDY DESIGN

Among the range of nozzles for fuel dispensing, PIUSI A60/A80/A120/A140 consist of a range of automatic devices for flow rates up to 140 l/min fitted with an inner device that automatically stops the fluid dispensing when the tank is full. These nozzles also include a swivel connector.

PERFORMANCE

UP TO 140 L/MIN	1" BSP
FLOW RATE	INLET
A60 24MM	A80/A120/A140 29MM
SPOUT	SPOUT



A60



A80



A120



A140



PACKAGING

CODE		WEIGHT		PACKAGING			BOXES/EUROPALLET	
WITHOUT SWIVEL	WITH SWIVEL	KG	LBS	MM	INCH	PCS/BOX		
A60								
-	FOO603060	1,25	2,76	360X360X280	14X14X11	1	-	-
-	FOO602020	1,20	2,65	360X360X280	14X14X11	1	-	-
-	FOO613A00	1,30	2,87	360X360X280	14X14X11	1	-	-
-	FOO870010	1,70	3,74	360X360X280	14X14X11	1	-	-
A80								
-	FOO604030	1,93	4,25	360X360X280	14X14X11	1	-	-
A120								
-	FOO610020	1,93	4,25	360X360X280	14X14X11	1	-	-
-	FOO614A00	1,65	3,64	360X360X280	14X14X11	1	-	-
A140								
FOO610200	-	2,00	4,41	460X200X80	181X78X31	1	-	-



FILTRATION



TANK MONITORING



HOSE REEL



ACCESSORIES



MERCHANDISE

INDEX



AIR



ANTIFREEZE



AdBlue®



BIODIESEL



DIESEL



FOOD



GASOLINE



GREASE



KEROSENE



OIL



WATER



WINDSCREEN

CHART

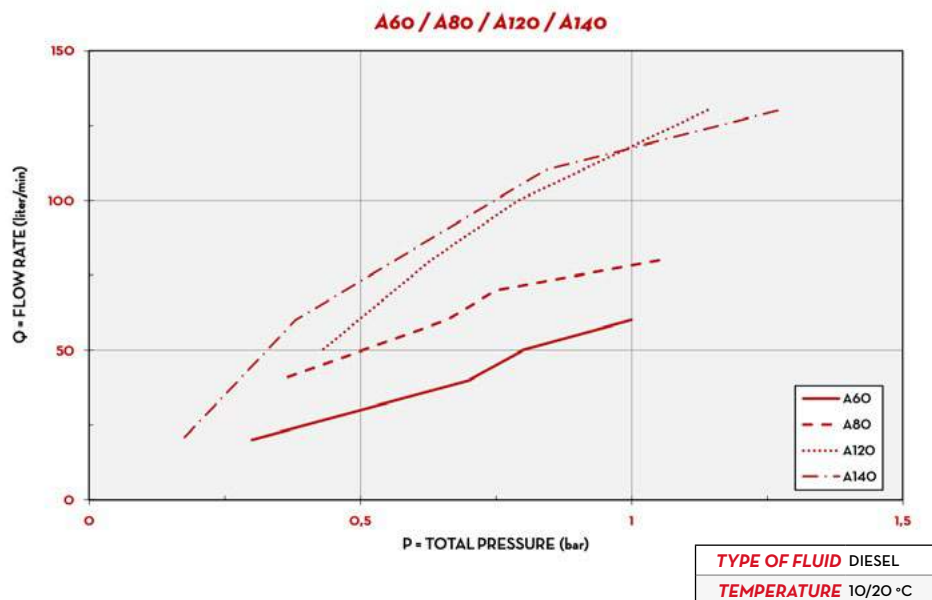

IN THE BOX

- A60/A80/A120/A140 NOZZLE
- INSTRUCTION MANUAL

DETAILS



DIMENSIONS

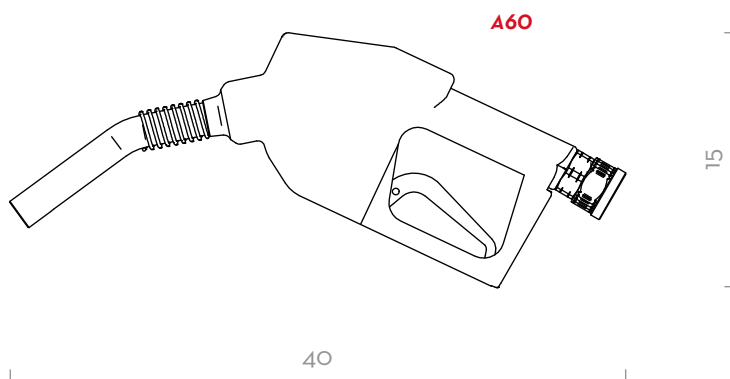

Dimensions expressed in millimeters

MATERIALS

- BODY: ALUMINIUM
- SEAL: VITON

TECHNICAL DATA

CODE		DESCRIPTION	FLUIDS TYPE	FLOW RATE		INLET		SPOUT
WITHOUT SWIVEL	WITH SWIVEL			L/MIN	GPM	WITHOUT SWIVEL BSP	WITH SWIVEL BSP	EXT. Ø MM
A60								
-	FO0603060	AUTOMATIC NOZZLE A60 W/SWIVEL 3/4" BSP	D G	60	16	F3/4"	F1"	20
-	FO0602020	AUTO NOZZLE A60 W/SWIVEL 3/4" UNLEADED	D G	60	16	F3/4"	F1"	20
-	FO0613A00	AUTO NOZZLE A60 EN 13012 W/SWIVEL 3/4"	D	70	19	F3/4"	F1"	24
-	FO0870010	AUTOMATIC NOZZLE A60 W/K24 METER BLACK	D	70	19	-	F1"	24
A80								
-	FO0604030	AUTOMATIC NOZZLE A80 W/SWIVEL 1" BSP	D G	90	24	-	F1"	29
A120								
-	FO0610020	AUTOMATIC NOZZLE A120 W/SWIVEL 1" BSP	D G	120	32	-	F1"	29
-	FO0614A00	AUTO NOZZLE A120 EN 13012 W/SWIVEL 1"	D	120	32	-	F1"	29
A140								
-	FO0610200	AUTOMATIC NOZZLE A140 W/SWIVEL 1" BSP	D	140	37	-	F1"	29

A60 / A80 / A120 / A140

AUTOMATIC NOZZLES



FUEL MANAGEMENT SYSTEMS



DISPENSERS



KITS



PUMPS



METERS



NOZZLES

A280

FEATURES

- AUTOMATIC
- READY TO USE
- HEAVY DUTY CONDITIONS
- STURDY STRUCTURE

The PIUSI A280 is the biggest nozzle among the PIUSI range of automatic fuel nozzles with its flow rate up to 280 l/min and spout OD 38,5 mm. Fully automatic thanks to the structural device that stops dispensing when the tank is full; it comes with a built-in swivel to guarantee maximum versatility.

PERFORMANCE

UP TO

280 L/MIN

FLOW RATE

1" 1/2 BSP

INLET

38,5MM

OD SPOUT

A280



A280



PACKAGING

CODE	WEIGHT		PACKAGING			N. BOXES / EUROPALET	
	KG	LBS	MM	INCH	PCS/BOX	✕	
F13249000	3,30	7,28	-	-	1	-	-



FILTRATION



TANK MONITORING



HOSE REEL



ACCESSORIES



MERCHANDISE

INDEX



AIR



ANTIFREEZE



AdBlue®



BIODIESEL



DIESEL



FOOD



GASOLINE



GREASE



KEROSENE



OIL



WATER



WINDSCREEN

CHART

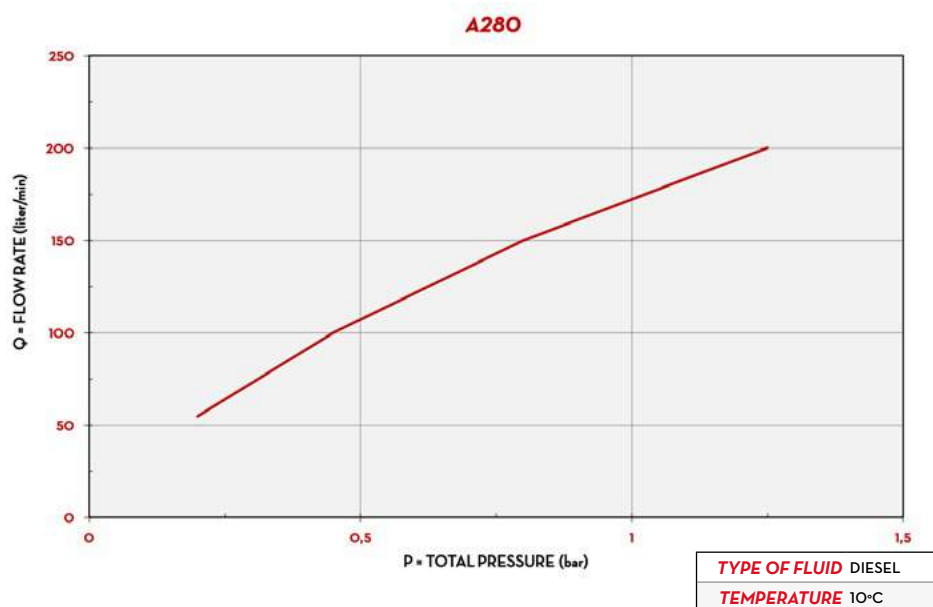

IN THE BOX

- A280 NOZZLE
- INSTRUCTION MANUAL

DETAILS



DIMENSIONS

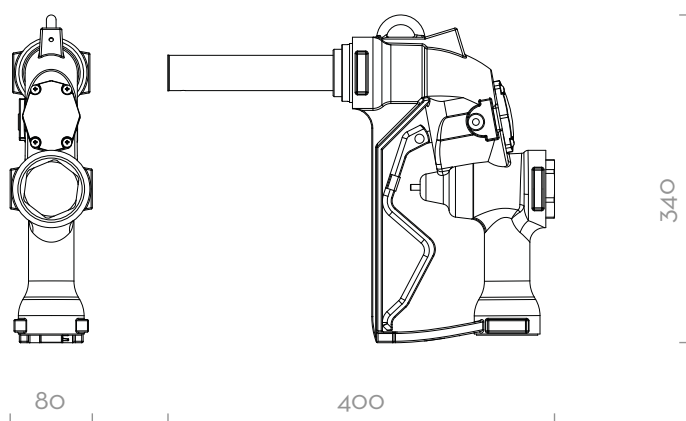

Dimensions expressed in millimeters

MATERIALS

- BODY: ALUMINIUM
- SEAL: VITON

TECHNICAL DATA

CODE	DESCRIPTION	FLUIDS TYPE	FLOW RATE		INLET		SPOUT
			L/MIN	GPM	WITHOUT SWIVEL BSP	WITH SWIVEL BSP	EXT. Ø MM
F13249000	AUTOMATIC NOZZLE A280 1" 1/2 BSP	D	280	74	-	1 1/2"	38,5

A280



FUEL MANAGEMENT SYSTEMS



DISPENSERS



KITS



PUMPS



METERS



NOZZLES

SELF 2000 / SELF 3000

FEATURES

- MANUAL
- VERSATILE
- HIGH EFFICIENCY
- LEVER PROTECTION

The PIUSI SELF 2000 / SELF 3000 manual nozzles perform the maximum efficiency thanks to the low-flow resistance and the wide range of applications including transfer systems run by gravity. They are supplied with removable lever protection and connectors.

PERFORMANCE

UP TO

150 L/MIN

FLOW RATE

25MM

OD SPOUT

SELF 2000 / SELF 3000



SELF 2000 DIESEL



SELF 3000 DIESEL/GASOLINE



PLASTIC NOZZLE WATER/DIESEL



PLASTIC NOZZLE WATER/FOOD



PACKAGING

CODE	WEIGHT		PACKAGING			N. BOXES / EUROPALLET	
	KG	LBS	MM	INCH	PCS/BOX		
00063900A	0,7	1,5	400X250X200	16X11X7,8	1		
00064900A	0,7	1,5	400X250X200	16X11X7,8	1		
00064902A	0,7	1,5	400X250X200	16X11X7,8	1		
00065001A	0,7	1,5	400X250X200	16X11X7,8	1		
00065600A	0,7	1,5	400X250X200	16X11X7,8	1		
FO0641120	0,7	1,5	400X250X200	16X11X7,8	1		
FO0641130	0,7	1,5	400X250X200	16X11X7,8	1		
FO065000A	0,7	1,5	400X250X200	16X11X7,8	1		
FO0650020	0,7	1,5	400X250X200	16X11X7,8	1		
FO063000A	0,3	0,7	-	-	1		



FILTRATION



TANK MONITORING



HOSE REEL



ACCESSORIES



MERCHANDISE

INDEX



AIR



ANTIFREEZE



AdBlue®



BIODIESEL



DIESEL



FOOD



GASOLINE



GREASE



KEROSENE



OIL



WATER



WINDSCREEN

CHART



IN THE BOX

- SELF 2000/ SELF 3000 NOZZLE
- INSTRUCTION MANUAL

DETAILS



DIMENSIONS

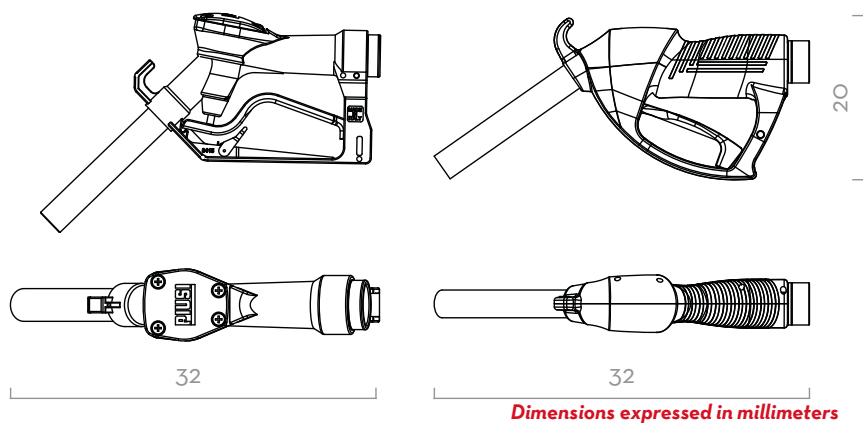

MATERIALS

- BODY: ALUMINIUM
- SEAL: VITON

TECHNICAL DATA



CODE	DESCRIPTION	FLUIDS TYPE	FLOW RATE		INLET		SPOUT	
			L/MIN	GPM	SWIVEL	Ø BSP	EXT. Ø MM	
00063900A	SELF 2000 1" BSP UNLEADED	B D G O	120	32	FEMALE	1" BSP	20	
00064900A	SELF 2000 3/4" BSP	B D O	120	32	FEMALE	3/4" BSP	25	
00064902A	SELF 2000 3/4" BSP UNLEADED	B D G O	120	32	FEMALE	3/4" BSP	20	
00065001A	SELF 3000 1" BSP UNLEADED	B D O G	150	40	FEMALE	1" BSP	20	
00065600A	SELF 2000 1" BSP SPOUT 25 MM	B D O	120	32	FEMALE	1" BSP	25	
FO0641120	SELF 2000 W/HOSE TAIL D.20 SPOUT 25 MM	B D O	120	32	FEMALE	3/4" BSP	25	
FO0641130	SELF 2000 1" BSP	B D O	120	32	FEMALE	1" BSP	25	
FO065000A	SELF 3000 1" BSP LEADED SPOUT	B D O	150	40	FEMALE	1" BSP	25	
FO0650020	SELF 3000 1" BSP LEADED SPOUT S/P	B D G O W	150	40	FEMALE	1" BSP	25	
FO063000A	PLASTIC NOZZLE BLACK W/SWIVEL 1" BSP	B D O W	80	21	FEMALE	1" BSP	34	

SELF 2000 / SELF 3000



NOZZLES ACCESSORIES

AUTOMATIC NOZZLES

A60 / A80 / A120 / A140	CODE	DESCRIPTION	
	FOO623100	SWIVEL 34.1 M W/FILTER	
	FOO62500A	SWIVEL 3/4IN X 20MMs	

FOO623100



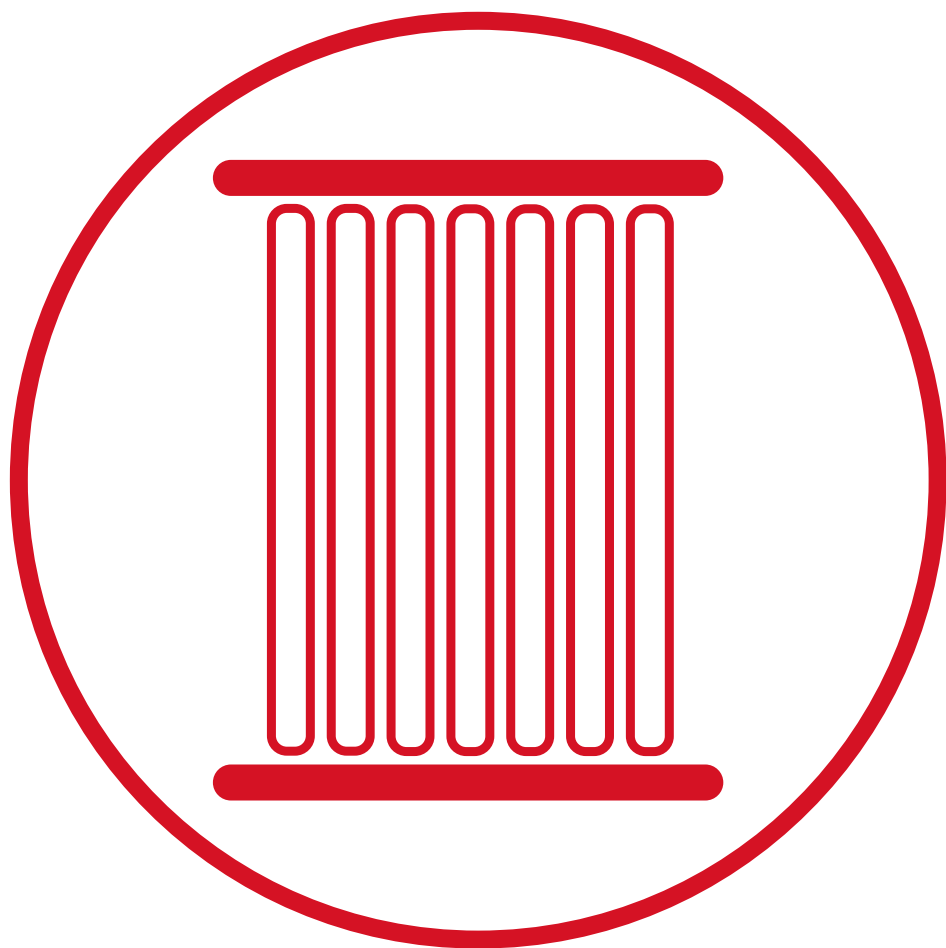

FILTRATION

A large, solid red triangle is positioned in the bottom right corner of the page, pointing towards the top right. The rest of the page is white.



FUEL MANAGEMENT SYSTEMS



DISPENSERS



KITS



PUMPS



METERS



NOZZLES

FILTROLL

FEATURES

- DOUBLE-STAGE FILTRATION
- SPIRAL TUBE
- EASY TO HANDLE
- LARGE-DIAMETER WHEELS

The PIUSI FILTROLL is an innovative portable unit that provides a complete double filtering capacity of any kind of tank while absorbing water and impurities. The built-in sturdy trolley allows the operator to easily handle this device in any condition. It is equipped with suction pipe and integrated bottom valve.

PERFORMANCE

UP TO

56 L/MIN

FLOW RATE

AC/DC

VOLTAGE

POWER

30μ

WATER ABSORPTION

FILTERING

5μ

IMPURITIES

FILTERING



FILTROLL

PACKAGING

CODE	WEIGHT		PACKAGING		
	KG	LBS	MM	INCH	PCS/BOX
FO0506000	35	77,2	790X590X590	31,1X23,2X23,2	1
FO050606A	40	88,2	790X590X590	31,1X23,2X23,2	1



FILTRATION



TANK MONITORING



HOSE REEL



ACCESSORIES



MERCHANDISE

PIUSI[®]

INDEX



AIR



ANTIFREEZE



AdBlue[®]



BIODIESEL



DIESEL



FOOD



GASOLINE



GREASE



KEROSENE



OIL



WATER



WINDSCREEN

CHART

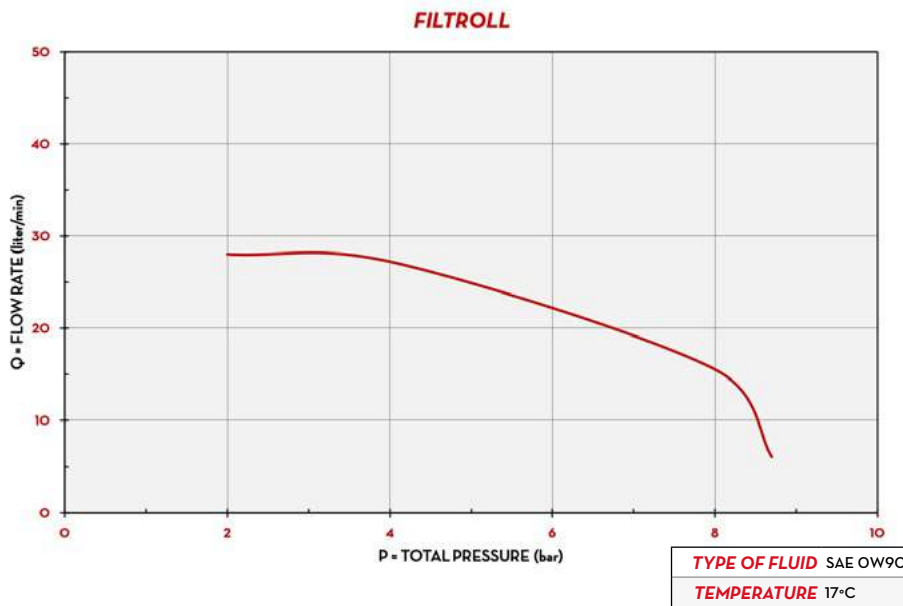

IN THE BOX

- FILTROLL UNIT
- SUCTION HOSE
- DELIVERY HOSE
- NOZZLE
- INSTRUCTION MANUAL

DETAILS



TWO-STEP FILTRATION



WATER/IMPURITIES FILTERS

DIMENSIONS

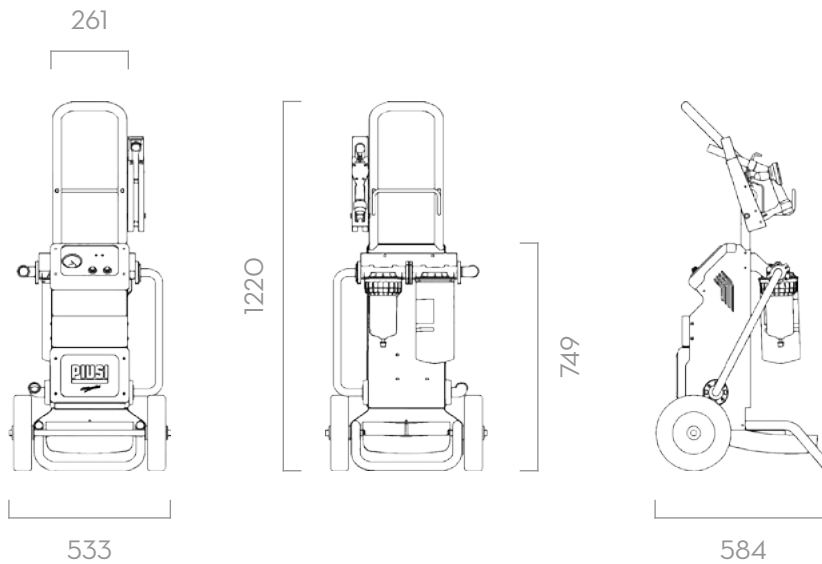

MATERIALS

- BODY: CAST IRON
- ROTOR: SINTERED STEEL
- VANES: TECHNOPOLYMER
- SHAFT: STEEL
- FILTER: ABSORBENT FILTERING PAPER

TECHNICAL DATA

CODE	DESCRIPTION	FLUIDS TYPE	FLOW RATE		VOLTAGE			PUMP TYPE	HOSE LENGTH	
			L/MIN	GPM	AC V/ HZ DC VOLT	POWER WATT	AMP. MAX.		DELIVERY M/FT.	SUCTION M/FT.
FO0506000	FILTROLL DIESEL	D	56	14,8	230/50-60	350/600	3/6	PANTH. 56	4 / 13,1	3 / 9,8
FO050606A	FILTROLL 12V DIESEL	D	56	14,8	12	300	35	PANTH. DC	4 / 13,1	4 / 13,1

AVAILABLE IN VERSION 230V/60HZ, 120V/60HZ

FILTROLL

FILTERING SYSTEM

169



FUEL MANAGEMENT SYSTEMS



DISPENSERS



KITS



PUMPS



METERS



NOZZLES

WATER CAPTOR

FEATURES

- BURSTING PRESSURE 10 BAR
- REPLACEABLE CARTRIDGE
- HIGH EFFICIENCY
- SMALL SIZE

The PIUSI WATER CAPTOR is a filter that absorbs any residual water particles that may be present in the fluid. The innovative cartridge needs to be replaced when filtering capacity is reduced due to the amount of water particles already absorbed. Available both for 70 or 150 l/min flow rates, these filters are also available with 1" inch fitting.

PERFORMANCE

UP TO

150 L/MIN

FLOW RATE

3,5 BAR

MAX

OPERATING PRESSURE

200β/30μ

FILTERING CAPACITY



WATER CAPTOR 150 L/MIN



PACKAGING

CODE	WEIGHT	PACKAGING		
	KG	DIMENSIONS MM	CARTRIDGE PSC / BOX	FILTER HEAD PCS/BOX
WATER CAPTOR				
FOO611A0A	2,4	390X285X140	2	1
FOO611A1A	2,3	390X285X140	1	1
WATER CAPTOR CARTRIDGE				
FOO611O1A	9,8	420X320X250	12	-
FOO611O2A	9,7	350X350X360	6	-
WATER CAPTOR FILTER HEAD				
F14640000	-	357X357X275	-	50
F15743000	0,9	200X120X240	-	1



FILTRATION



TANK MONITORING



HOSE REEL



ACCESSORIES



MERCHANDISE

PIUSI[®]

INDEX



AIR



ANTIFREEZE



AdBlue[®]



BIODIESEL



DIESEL



FOOD



GASOLINE



GREASE



KEROSENE



OIL



WATER



WINDSCREEN

PRODUCTS



150 L/MIN WATER CAPTOR
WITH WATER ABSORPTION



70 L/MIN WATER CAPTOR
WITH WATER ABSORPTION

IN THE BOX

- FILTER HEAD
- WATER CAPTOR CARTRIDGE
- INSTRUCTION MANUAL

DETAILS



FILTER HEAD



WATER CAPTOR CARTRIDGE

DIMENSIONS

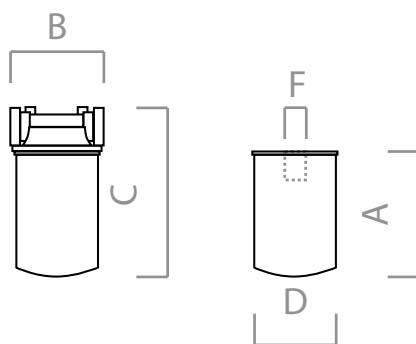

Dimensions expressed in millimeters

CODE	A (MM)	B (MM)	C (MM)	D (MM)	F
FOO611A00	-	100	280	95	-
FOO611A10	-	171	340	120	-
FOO611O10	220	-	-	95	1"-12 UNF
FOO611O20	275	-	-	120	1 1/2"-16 UNF
F14640000	-	100	-	-	1"-12 UNF
F15743000	-	171	-	-	1 1/2"-16 UNF 1 1/4" BSP

MATERIALS

- FILTER: ABSORBENT FILTERING PAPER

TECHNICAL DATA

CODE	DESCRIPTION	FLUIDS TYPE	FLOW RATE		INLET / OUTLET BSP	WATER ABSORBING	EFFICIENCY β	MICRO μm	PRESSURE BAR
			L/MIN	GPM					
WATER CAPTOR									
FOO611A0A	WATER CAPTOR FILTER 70L/MIN - 2 CARTD IT	D G	70	18,5	1"	YES	200	30	3,5
FOO611A1A	WATER CAPTOR FILTER 150 L/MIN 1 CART IT	D G	150	39,6	1"	YES	200	30	3,5
WATER CAPTOR CARTRIDGE									
FOO611O1A	WATER CAPTOR CARTD. 70 L/MIN (12PCS) IT	D G	70	18,5	-	YES	200	30	3,5
FOO611O2A	WATER CAPTOR CART. 150 L/MIN (6PCS) IT	D G	150	39,6	-	YES	200	30	3,5
WATER CAPTOR FILTER HEAD									
F14640000	FILTER HEAD UNF 70 L/MIN	D G	-	-	1"	NO	-	-	-
F15743000	FILTER HEAD 70/100LT	D G	-	-	1"	NO	-	-	-

WATER CAPTOR

FILTERS

171



FUEL MANAGEMENT SYSTEMS



DISPENSERS



KITS



PUMPS



METERS



NOZZLES

CLEAR CAPTOR

FEATURES

- REPLACEABLE CARTRIDGE
- HIGH EFFICIENCY
- SMALL SIZE

The PIUSI CLEAR CAPTOR is a range of cartridge filters that can be applied both on suction or delivery flow directions. They are equipped with a high-performance cartridge and a plastic container to collect all eventual impurities or water particles that may be present in the fluid. Thanks to the valve at the bottom of the container, it is possible to remove contaminations quickly and safely to ensure the maximum possible filter life.

PERFORMANCE

UP TO
150 L/MIN

FLOW RATE

5 BAR
MAX

OPERATING PRESSURE

2β/5μ

FILTERING CAPACITY



PACKAGING

CODE	WEIGHT	PACKAGING		
	KG	DIMENSIONS MM	CARTRIDGE PSC / BOX	FILTER HEAD PCS/BOX
CLEAR CAPTOR				
FO0611B00	2,3	390X285X140	2	1
FO0611B10	2,0	390X285X140	2	1
FO0611B60	2,3	390X285X140	1	1
CLEAR CAPTOR CARTRIDGE				
FO0611O30	1,9	190X190X240	6	-
FO0611O40	1,2	190X190X240	6	-
FO0611O60	0,2	190X190X240	1	1
CLEAR CAPTOR FILTER HEAD				
F15744000	1,0	200X120X240	-	1



FILTRATION



TANK MONITORING



HOSE REEL



ACCESSORIES



MERCHANDISE

PIUSI

INDEX



AIR



ANTIFREEZE



AdBlue®



BIODIESEL



DIESEL



FOOD



GASOLINE



GREASE



KEROSENE



OIL



WATER



WINDSCREEN

PRODUCTS



DIMENSIONS

CODE	A (MM)	B (MM)	C (MM)	D (MM)	F
FOO611B00	-	171	270	-	-
FOO611B10	-	171	270	-	-
FOO611B60	-	171	270	-	-
FOO611O30	110	-	-	75	1" BSP M
FOO611O40	155	-	-	75	1" BSP M
FOO611O60	110	-	-	75	1" BSP M
F15744000	-	171	-	-	1" BSP F

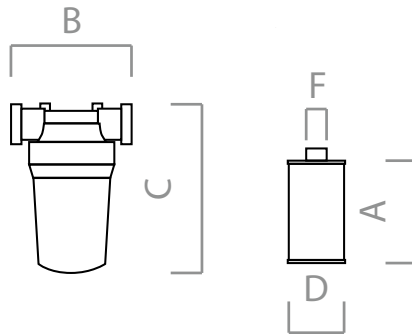

IN THE BOX

- FILTER CARTRIDGE
- METALLIC HEAD
- ADDITIONAL CARTRIDGE
- INSTRUCTION MANUAL

DETAILS



STRAINER CARTRIDGE



IMPURITIES PAPER CARTRIDGE



WATER PAPER CARTRIDGE



DRAIN VALVE

MATERIALS

- FILTER: ABSORBENT FILTERING PAPER

TECHNICAL DATA

CODE	DESCRIPTION	FLUIDS TYPE	FLOW RATE		INLET / OUTLET BSP	WATER ABSORBING	EFFICIENCY β	MICRO μ m	PRESSURE BAR
			L/MIN	GPM					
CLEAR CAPTOR									
FOO611B00	CLEAR CAPTOR FILTER	B D G	100	26,4	1"	NO	2	5	5
FOO611B10	CLEAR CAPTOR WATER FILTER	B D G	70	18,5	1"	YES	200	30	5
FOO611B60	CLEAR CAPTOR STRAINER	B D G	100	26,4	1"	NO	2	125	5
CLEAR CAPTOR CARTRIDGE									
FOO611O30	CLEAR CAPTOR CARTRIDGE	B D G	100	26,4	-	NO	2	5	-
FOO611O40	CLEAR CAPTOR WATER FILTER CARTRIDGE	B D G	70	18,5	-	YES	200	30	-
FOO611O60	CLEAR CAPTOR STRAINER CARTRIDGE	B D G	100	26,4	-	NO	2	125	-
CLEAR CAPTOR FILTER HEAD									
F15744000	FILTER HEAD CLEAR CAPTOR	B D G	-	-	1"	NO	-	-	-

CLEAR CAPTOR

FILTERS

173



FUEL MANAGEMENT SYSTEMS



DISPENSERS



KITS



PUMPS



METERS



NOZZLES

FUEL & BIOFUEL

FEATURES

- BURSTING PRESSURE 10 BAR
- REPLACEABLE CARTRIDGE
- HIGH EFFICIENCY
- SMALL SIZE

Among its range of filters, PIUSI has developed the FUEL&BIOFUEL FILTER: cartridge and water absorbing filters that prevent fluid contamination thanks to their improved filtration capacity up to 30µ.

PERFORMANCE

UP TO 100 L/MIN	3,5 BAR MAX
FLOW RATE	OPERATING PRESSURE
FILTERING CAPACITY 200β/10µ	FILTERING CAPACITY 2β/5-10µ
BIOFUEL	FUEL



BIO-FUEL FILTER



OIL AND FUEL FILTER



LINE FILTER 1-1



PACKAGING

CODE	WEIGHT	DIMENSIONS MM	PACKAGING	
	KG		CARTRIDGE PSC / BOX	FILTER HEAD PCS/BOX
BIOFUEL FILTERS				
FO0611C00	2	390X285X140	2	1
FO0611C10	1,9	390X285X140	1	1
BIOFUEL FILTER CARTRIDGE				
F14861000	-	-	1	-
FUEL FILTERS				
FO777200A	1	200X120X140	1	1
FO9149020	2,6	390X285X140	1	1
FUEL FILTERS CARTRIDGE				
FO9359010	-	-	1	-
F16483010	9,2	500X300X200	15	-
FILTER HEAD				
F14528000	-	-	-	1
INLINE FILTER				
FO8950000	-	-	-	-



FILTRATION



TANK MONITORING



HOSE REEL



ACCESSORIES



MERCHANDISE

PIUSI[®]

INDEX



AIR



ANTIFREEZE



AdBlue[®]



BIODIESEL



DIESEL



FOOD



GASOLINE



GREASE



KEROSENE



OIL



WATER



WINDSCREEN

DIMENSIONS

A B C D F
(MM) (MM) (MM) (MM)

FILTER FOR BIOFUEL

FO0611C00	-	100	275	95	-
FO0611C10	-	171	340	130	-
F14861000	220	-	-	95	1" - 12 UNF
R14862000	275	-	-	130	1" 1/2 - 16 UNF
F14640000	-	100	-	-	1" - 12 UNF
F15743000	-	171	-	-	1" 1/2 - 16 UNF 1" 1/4 BSP

FILTER FOR FUEL AND OIL

FO777200A	-	100	160	98	-
FO914900A	-	171	236	132	-
FO9149020	-	171	236	132	-
FO0611000	145	-	-	98	3/4" BSP
FO9359000	180	-	-	132	1" 1/4 BSP
FO9359010	180	-	-	132	1" 1/4 BSP
F14528000	-	100	-	-	3/4" BSP
F15743000	-	171	-	-	1" 1/2 - 16 UNF 1" 1/4 BSP
F16483010	139	-	-	93	3/4" BSP

LINE FILTER

FO8950000	-	-	-	-	-
-----------	---	---	---	---	---

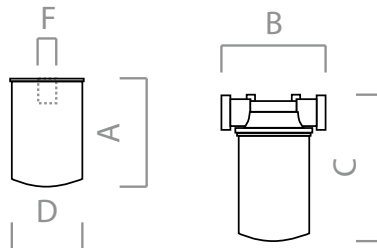

BIO-FUEL / OIL AND FUEL FILTERS

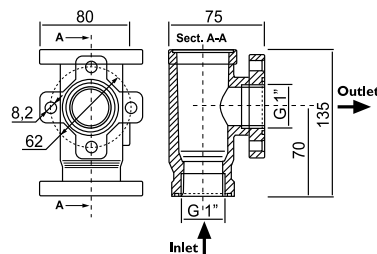

LINE FILTER 1-1

Dimensions expressed in millimeters

IN THE BOX

- FILTER CARTRIDGE
- METALLIC HEAD
- ADDITIONAL CARTRIDGE
- INSTRUCTION MANUAL

DETAILS



FILTER HEAD



REPLACEABLE CARTRIDGE



MESH STRAINER



LINE FILTER

MATERIALS

- FILTER: ABSORBENT FILTERING PAPER

TECHNICAL DATA

CODE	DESCRIPTION	FLUIDS TYPE	FLOW RATE		INLET / OUTLET	WATER ABSORBING	EFFICIENCY	MICRO	PRESSURE
			L/MIN	GPM					

BIOFUEL FILTERS

FO0611C00	BIO-FUEL FILTER 70 L/MIN 1"X1"	B G	70	18,5	1"	YES	200	10	3,5
FO0611C10	BIO-FUEL FILTER 100 L/MIN 1"X1"	B G	100	26,4	1"	YES	200	10	3,5

BIOFUEL FILTER CARTRIDGE

F14861000	CARTRIDGE 70 L/MIN BIO-FUEL	B G	70	19,5	-	YES	200	10	FUEL
-----------	-----------------------------	-----	----	------	---	-----	-----	----	------

FUEL FILTERS

FO777200A	60 L/MIN FILTER WITH HEAD	B D G O	60	15,9	1"	NO	2	10	12
FO9149020	100 L/MIN FILTER WITH HEAD	B D G O	100	26,4	1"	NO	2	5	12

FUEL FILTERS CARTRIDGE

FO9359010	CARTRIDGE 100 L/MIN	B D G O	100	26,4	-	NO	2	5	12
F16483010	PIUSI BOX CARTRIDGE 60 L/MIN (15 PCS)	B D G O	60	15,9	-	NO	2	10	12

FILTER HEAD

F14528000	FILTER HEAD 3/4 BSP 60 L/MIN	B D G O	-	-	1"	NO	-	-	-
-----------	------------------------------	---------	---	---	----	----	---	---	---

INLINE FILTER

FO8950000	LINE FILTER	B D G O	-	-	1"	NO	-	-	-
-----------	-------------	---------	---	---	----	----	---	---	---

FUEL & BIOFUEL



FUEL MANAGEMENT SYSTEMS



DISPENSERS



KITS



PUMPS



METERS



NOZZLES

FOOT VALVE

FEATURES

- HEAVY DUTY
- STURDY STRUCTURE
- LOW PRESSURE DROP
- ANTI-SHOCK MATERIALS

The FOOT VALVE designed and engineered by PIUSI is a new concept of valve for fuel suction hoses on machinery. It is fitted with a mesh filter for diesel fuel residues, anti-shock materials to avoid damage caused by dropping and, thus, a low dropping pressure. The quick locking/unlocking and the clear indications of opening and closing complete its main features.

PERFORMANCE

125µ

FILTERING CAPACITY

1"-3/4"

BSP

INLET



FOOT VALVE WITH FILTER

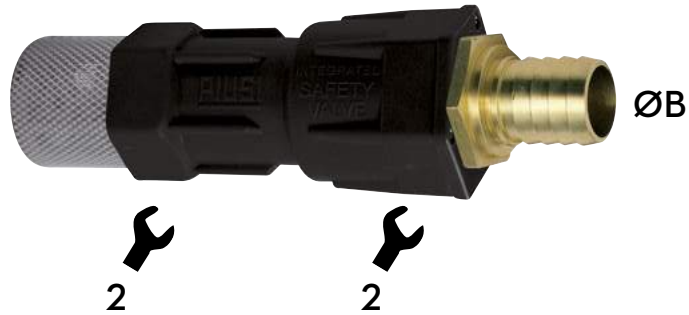

PACKAGING

CODE	WEIGHT		PACKAGING		
	KG	LBS	DIMENSIONS MM	INCH	PCS/BOX

FOOT VALVE WITH FILTER

FO0609000	2,5	5,3	180X180X170	7,1X7,1X6,7	10
FO0612000	0,2	0,44	-	-	1
F15749000	1,35	3	215X147X116	8,5X5,8X4,6	12
FO7978000	6,7	14,8	180X180X170	7,1X7,1X6,7	25
FO8153000	0,15	0,33	-	-	1
FO9170000	6,5	14,3	180X180X170	7,1X7,1X6,7	25



FILTRATION



TANK MONITORING



HOSE REEL



ACCESSORIES



MERCHANDISE

PIUSI[®]

INDEX



AIR



ANTIFREEZE



AdBlue[®]



BIODIESEL



DIESEL



FOOD



GASOLINE



GREASE



KEROSENE



OIL



WATER



WINDSCREEN

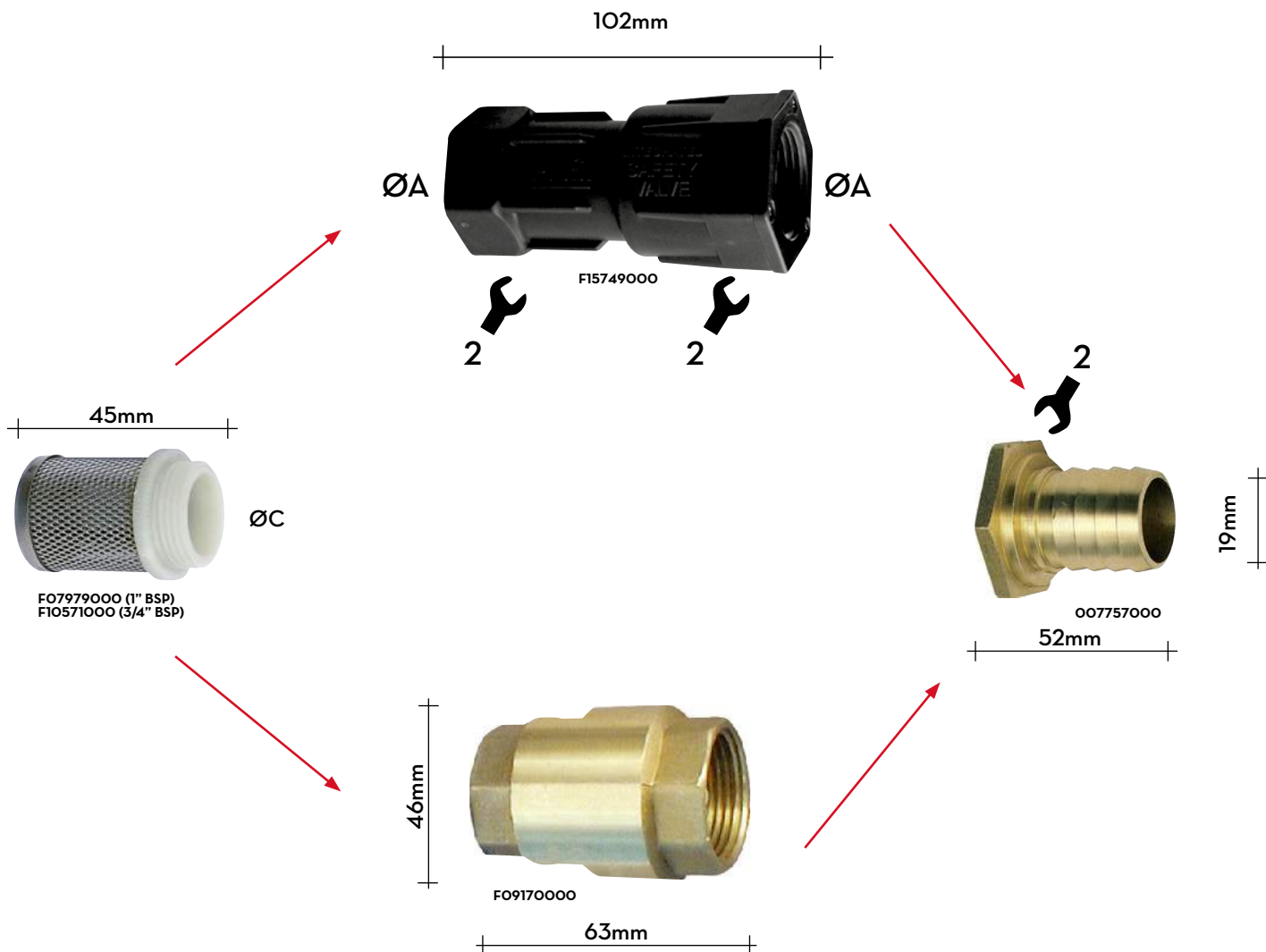

TECHNICAL DATA

CODE	DESCRIPTION	FLUIDS TYPE	SAFETY VALVE					A	B	C	KEY		MICRO
								Ø BSP	Ø BSP	Ø BSP	1	2	μm

FOOT VALVE WITH FILTER

F00609000	FOOT VALVE WITH FILTER 1" BSP	D G O	YES	YES	-	YES	YES	-	1"	-	38	-	125
F00612000	FOOT VALVE WITH FILTER 3/4" BSP	D G O	YES	YES	-	YES	YES	-	3/4"	-	31	-	125
F15749000	1" WITH BUILT-IN SAFETY VALVE	D G O	YES	YES	-	-	-	1"	-	-	-	42/46	-
F07978000	FOOT VALVE WO/FILTER 1" BSP	D G O	-	-	YES	-	-	-	-	1"	-	-	-
F08153000	FOOT VALVE WO/FILTER 3/4" BSP	D G O	-	-	YES	-	-	-	-	3/4"	-	-	-
F09170000	HIGH PRESSURE VALVE 1" BSP	D O	YES	-	YES	-	-	-	-	1"	-	-	-

FOOT VALVE



TANK MONITORING

A large, solid red triangle is positioned in the bottom right corner of the page, pointing towards the top right.



FUEL MANAGEMENT SYSTEMS



DISPENSERS



KITS



PUMPS



METERS



NOZZLES

OCIO

FEATURES

- LOW/HIGH LEVEL ALARMS
- FLUID MEASURES INDICATION
- BUILT-IN DISPLAY

OCIO is PIUSI's tank level indicator suitable for any kind of fluid stored in tanks up to a 4 mt depth. It gives a real time indication of the fluid quantity inside the tank. It is easy to calibrate and has two alarms that can be adjusted at a specific high and low level for high and low levels.

PERFORMANCE

UP TO 4MT HEIGHT TANK	± 1% FULL SCALE ACCURACY
UP TO 50 MT LENGTH PROBE TUBE	UP TO 30 CST VISCOSITY



OCIO



10 METERS HOSE



BRASS PROBE

PACKAGING

CODE	WEIGHT		PACKAGING		
	KG	LBS	MM	INCH	PCS/BOX
FO075510D	2,2	4,8	300X410X100	11,8X16,1X3,9	1
FO075516O	2,2	4,8	300X410X100	11,8X16,1X3,9	1



FILTRATION



TANK MONITORING



HOSE REEL



ACCESSORIES



MERCHANDISE

INDEX



AIR



ANTIFREEZE



AdBlue®



BIODIESEL



DIESEL



FOOD



GASOLINE



GREASE



KEROSENE



OIL



WATER



WINDSCREEN

FUNCTIONING

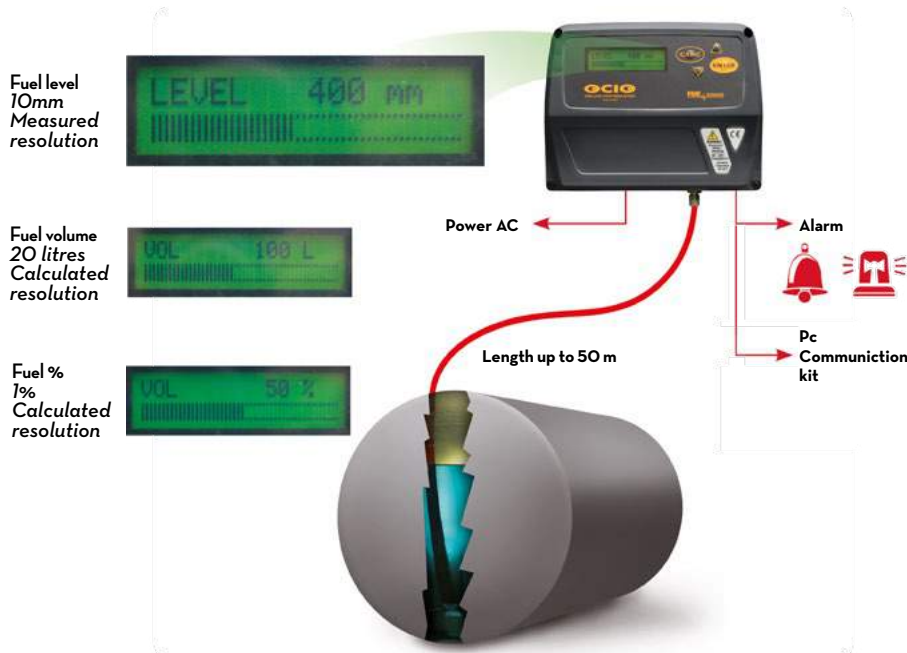

IN THE BOX

- OCIO UNIT
- PROBE
- 10 MT TUBE
- INSTRUCTION MANUAL

DETAILS



DIMENSIONS

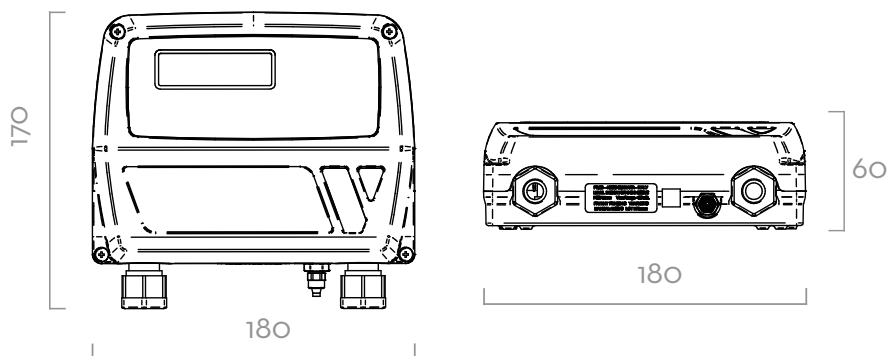

Dimensions expressed in millimeters

MATERIALS

- PROBE: BRASS
- TUBE: TECHNOPOLYMER

TECHNICAL DATA

CODE	DESCRIPTION	FLUIDS TYPE	VISCOSITY		VOLTAGE		RS EXIT
			cSt	AC V/HZ	POWER WATT		
FO075510D	LEVEL INDICATOR OCIO LV / RS OUTPUT	A B D O W	UP TO 30	230/50	20	AVAILABLE	
FO0755160	LEVEL INDICATOR OCIO LV / 4/20 mA OUTPUT	A B D O W	UP TO 30	230/50	20	AVAILABLE	



FUEL MANAGEMENT SYSTEMS



DISPENSERS



KITS



PUMPS



METERS



NOZZLES

OCIO 2.0

FEATURES

- LOW/HIGH LEVEL ALARMS
- FLUID QUANTITY INDICATION
- FLUID HEIGHT INDICATION
- BUILT-IN DISPLAY
- COMPATIBLE WITH SSM 2.0, MCO 2.0 AND B.SMART

With its brand-new design, OCIO 2.0 by PIUSI is the upgraded version of the tank level indicator compatible with SSM 2.0 and MCO 2.0 systems. It requires a LAN/Wi-Fi connection to communicate with the software. It maintains all the performances of the standard OCIO. Thanks to its interchangeable probe, OCIO 2.0 is compatible with several fluids.

PERFORMANCE

UP TO

4MT

HEIGHT

TANK

± 1%

FULL SCALE

ACCURACY

UP TO

50 MT

LENGTH

PROBE TUBE

UP TO

30 CST

VISCOSITY



OCIO 2.0

10 METERS HOSE

BRASS PROBE

PACKAGING

CODE	WEIGHT		PACKAGING		
	KG	LBS	MM	INCH	PCS/BOX
FO0755260	2,2	4,8	300X410X100	11,8X16,1X3,9	1
FO0755220	2,2	4,8	300X410X100	11,8X16,1X3,9	1
FO075521A	2,2	4,8	300X410X100	11,8X16,1X3,9	1



FILTRATION



TANK MONITORING



HOSE REEL



ACCESSORIES



MERCHANDISE

INDEX



AIR



ANTIFREEZE



AdBlue®



BIODIESEL



DIESEL



FOOD



GASOLINE



GREASE



KEROSENE



OIL



WATER



WINDSCREEN

CONNECTION



IN THE BOX

- OCIO 2.0
- PROBE
- 10 MT TUBE
- INSTRUCTION MANUAL

DETAILS



FUNCTIONING

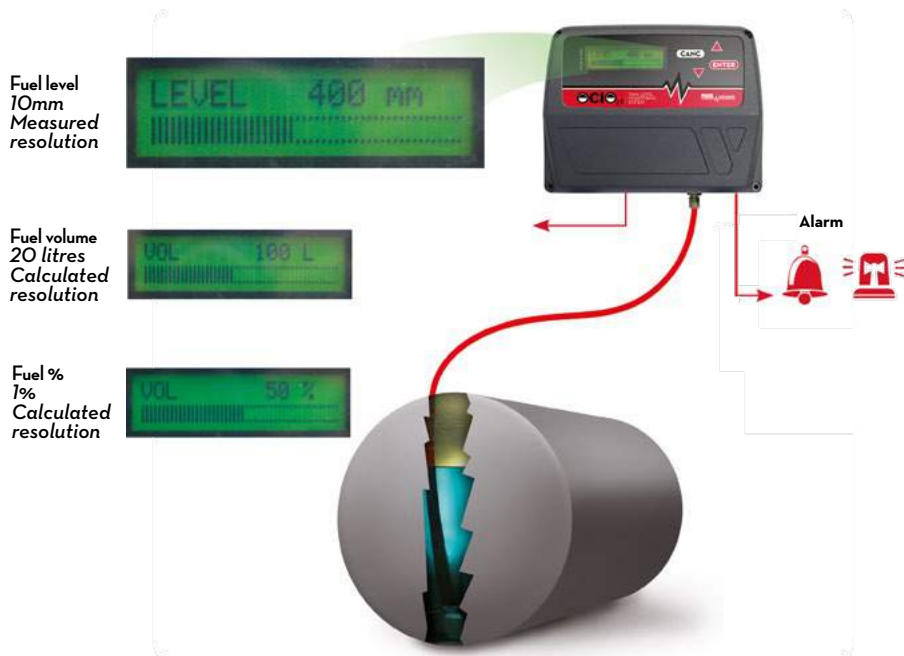

MATERIALS

- PROBE: BRASS
- TUBE: TECHNOPYLIMER

TECHNICAL DATA



CODE	DESCRIPTION	FLUIDS TYPE	VISCOSITY		VOLTAGE		RS EXIT
			cSt	AC V./HZ	POWER WATT		
FO0755260	LEVEL INDICATOR OCIO MC 2.0	A B D O W	UP TO 30	230-50/60	20	REQUIRED	
FO0755220	LEVEL INDICATOR OCIO RS485 2.0	A B D O W	UP TO 30	230-50/60	20	REQUIRED	
FO075521A	LEVEL INDICATOR OCIO WIFI 2.0	A B D O W	UP TO 30	230-50/60	20	REQUIRED	



OCIO 2.0



TANK MONITORING ACCESSORIES

TANK LEVEL INDICATORS

OCIO	CODE	DESCRIPTION	
	F1391300A	KIT 50 MT OCIO PIPE D.6X4	 F1391300A

OCIO 2.0	CODE	DESCRIPTION	
	F1391300A	KIT 50 MT OCIO PIPE D.6X4	 F1391300A



HOSE REEL

A solid red triangle pointing upwards from the bottom right corner of the page, extending towards the center.



FUEL MANAGEMENT SYSTEMS



DISPENSERS



KITS



PUMPS



METERS



NOZZLES

DIESEL HOSE REEL

FEATURES

- STURDY STRUCTURE
- HAND PROTECTION
- CORROSION RESISTANCE
- REDUCED PRESSURE LOSS
- HEAVY DUTY CONDITIONS

PIUSI automatic DIESEL HOSE REELS for diesel have been designed to ensure high efficiency. The sturdy structure can guarantee the best performance also in heavy duty conditions.

PERFORMANCE

15 BAR

MAX

OPERATING PRESSURE

MAX
20 MT

LENGTH

HOSE BOUND



AUTOMATIC HOSE REEL WITH HOSE



HOSE DIESEL HOSE REEL FOR 12M HOSE VERSION



PACKAGING

CODE	WEIGHT		PACKAGING			N. BOXES / EUROPALLET	
	KG	LBS	MM	INCH	PCS/BOX		

WITHOUT HOSE

FO075000A	19	41,9	550X260X540	-	1	12	20
FO075001A	18	39,7	550X260X540	-	1	12	20
FO075008A	15	33,1	550X260X540	-	1	12	20
FO075025A	27	59,5	560X350X560	-	1	12	20
FO0750310	21	46	550X260X540	-	1	12	20
FO075018B	21	46	550X260X540	-	1	12	20

WITH HOSE

FO075002B	26	57,3	550X260X540	-	1	12	20
FO075003B	25	55,1	550X260X540	-	1	12	20
FO075023B	18	39,7	550X260X540	-	1	12	20
FO075004B	22	49,5	550X260X540	-	1	12	20
FO075012B	22	49,5	550X260X540	-	1	12	20
FO075024B	18	39,7	550X260X540	-	1	12	20
FO075009B	19	41,9	550X260X540	-	1	12	20
FO075010B	27	59,5	550X260X540	-	1	12	20
FO075019B	27	59,5	560X350X560	-	1	8	12
FO075026B	27	59,5	560X350X560	-	1	8	12
FO075013B	23	50,7	550X260X540	-	1	12	20



FILTRATION



TANK MONITORING



HOSE REEL



ACCESSORIES



MERCHANDISE

INDEX



AIR



ANTIFREEZE



AdBlue®



BIODIESEL



DIESEL



FOOD



GASOLINE



GREASE



KEROSENE



OIL



WATER



WINDSCREEN

INSTALLATION&DIMENSIONS

Different ways to install PIUSI's hose reels: they can be easily placed wherever you need them without any problem about functionality and safety. PIUSI's products are without a doubt designed to support your work in any condition.

ROOF INSTALLATION

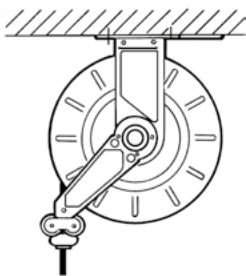

WALL INSTALLATION

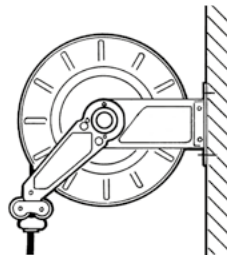

GROUND INSTALLATION

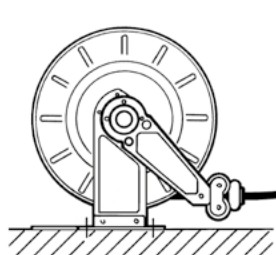

MODEL HOSE REEL XL HOSE REEL BIG HOSE REEL SMALL

A	512	495	475
B	470	460	460
C	227	152	102
D	200	200	150
E	322	246	196
F	160	150	150
G	260	200	150
H	12	12	12
L	382	306	256

HOSE REEL FRONT / SIDE

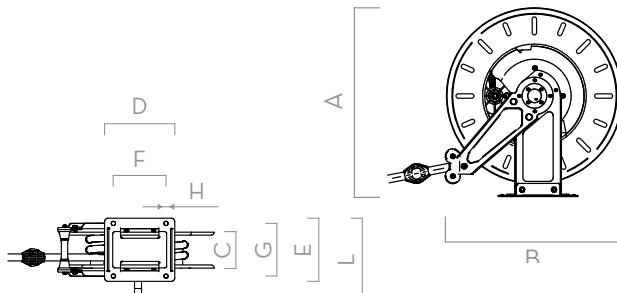

Dimensions expressed in millimeters

IN THE BOX

- REEL
- WALL MOUNT BRACKET
- INSTRUCTION MANUAL

DETAILS



4 ROLLS HOSE GUIDE



AUTOMATIC HOSE REELS

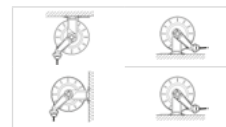

DIFFERENT INSTALLATIONS



STURDY DESIGN

MATERIALS

- BODY: CAST IRON
- HUB: SYNTHETIC STEEL
- TUBE: RUBBER

TECHNICAL DATA

CODE	DESCRIPTION	FLUIDS TYPE	HOSE	MAX OPERATING PRESSURE	PRESSURE DROP	INLET	OUTLET	HOSE MAX LENGTH BOUND	HOSE LENGTH
			BSP	BAR	TYPE	WITH SWIVEL BSP	HOSE TAIL BSP	METERS	METER

WITHOUT HOSE

FO075000A	HOSE REEL 3/4" BIG	D	3/4"	10	0,15 @ 60 L/MIN	1" MALE	3/4"	14	-
FO075001A	HOSE REEL 1" BIG	D	1"	10	0,2 @ 80 L/MIN	1" MALE	1"	10	-
FO075008A	HOSE REEL 3/4" SMALL	D	3/4"	10	0,15 @ 60 L/MIN	1" MALE	3/4"	10	-
FO075025A	HOSE REEL 1" XL HEAVY DUTY (STEEL HUB)	D	1"	15	0,5 @ 80 L/MIN	1" FEMALE	1" MALE	15	-
FO0750310	HOSE REEL NAKED XL 20M	D	3/4"	10	0,15 @ 60 L/MIN	1" FEMALE	3/4" MALE	20	-
FO075018B	HOSE REEL NAKED XL 15M	D	1"	10	0,2 @ 80 L/MIN	1" FEMALE	1" MALE	15	-

WITH HOSE

FO075002B	HOSE REEL 8X1" BIG	D	1"	10	0,6 @ 80 L/MIN	1" FEMALE	1" MALE	-	8
FO075003B	HOSE REEL 10X1" BIG	D	1"	10	0,7 @ 80 L/MIN	1" FEMALE	1" MALE	-	10
FO075023B	HOSE REEL 10X1" BIG HEAVY DUTY (STEEL HUB)	D	1"	10	0,7 @ 80 L/MIN	1" FEMALE	1" MALE	-	10
FO075004B	HOSE REEL 10X3/4" BIG	D	3/4"	10	0,7 @ 60 L/MIN	1" FEMALE	1" MALE	-	10
FO075012B	HOSE REEL 10X3/4" BIG	D	3/4"	10	0,7 @ 60 L/MIN	1" FEMALE	3/4" MALE	-	10
FO075024B	HOSE REEL 10X3/4" BIG HEAVY DUTY (STEEL HUB)	D	3/4"	10	0,9 @ 60 L/MIN	1" FEMALE	1" MALE	-	10
FO075009B	HOSE REEL 8X3/4" SMALL	D	3/4"	10	0,6 @ 60 L/MIN	1" FEMALE	1" MALE	-	8
FO075010B	HOSE REEL 14X3/4" BIG	D	3/4"	10	0,6 @ 60 L/MIN	1" FEMALE	1" MALE	-	14
FO075019B	HOSE REEL 15X1" XL	D	1"	15	1 @ 80 L/MIN	1" FEMALE	1" MALE	-	15
FO075026B	HOSE REEL 15X1" XL HEAVY DUTY (STEEL HUB)	D	1"	15	0,8 @ 80 L/MIN	1" FEMALE	1" MALE	-	15
FO075013B	HOSE REEL 10 X 3/4" BIG GASOLINE	D	3/4"	15	0,7 @ 80 L/MIN	1" FEMALE	1" MALE	-	10

MINIMUM RADIUS OF CURVATURE FOR 3/4 HOSE SIZES "AND 1" OF AT LEAST 130MM; ELECTRICALLY, THE HOSE MUST BE CONDUCTOR R-1 MOhm/m

DIESEL HOSE REEL

OPEN HOSE REEL



HOSE REELS

ACCESSORIES

OPEN HOSE REEL

DIESEL HOSE REEL	CODE	DESCRIPTION
	F1627900A	BIG HOSE REEL ROTATING SUPPORT
	F1629800A	BIG HOSE REEL FIXED BASE
	F16367000	DIESEL HOSE Ø25 L=1M CRIMPED T"XI"
	F1731600A	SMALL HOSE REEL FIXED BASE
	F1731700A	SMALL HOSE REEL ROTATING SUPPORT



F1629800A F1627900A F16367000
F1731600A F1731700A



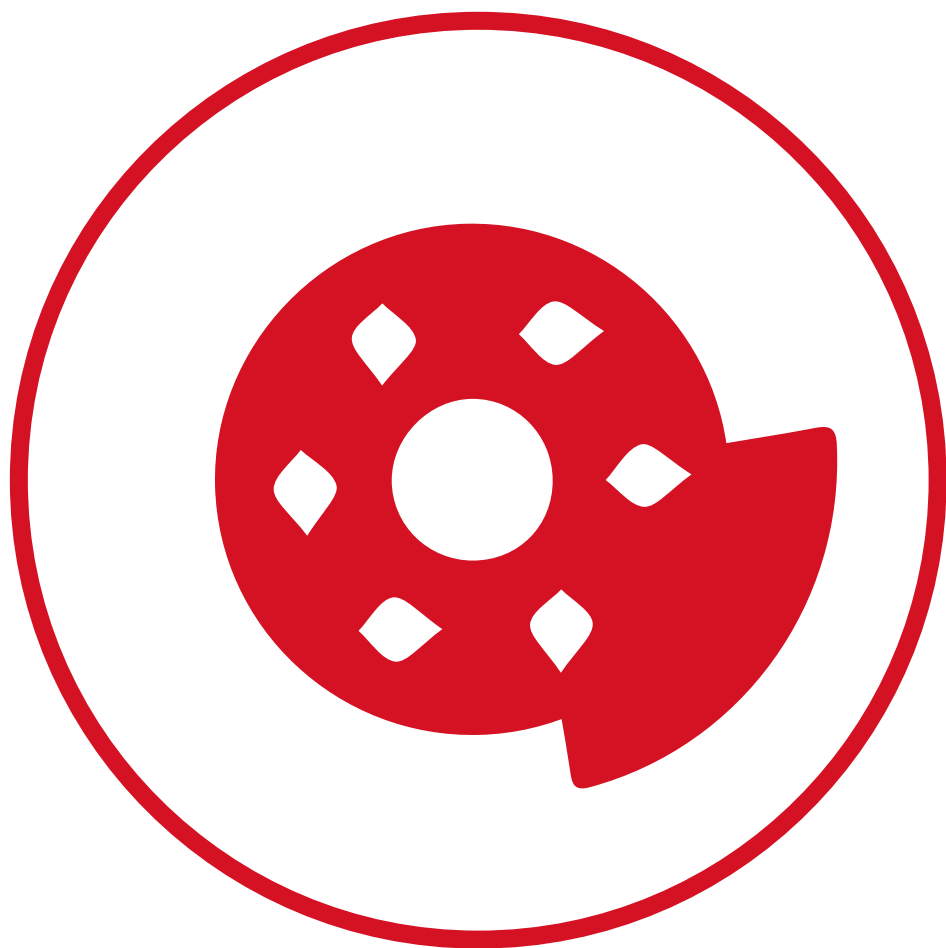

ACCESSORIES

A large, solid red triangle is positioned in the bottom right corner of the page, pointing towards the top right.



FUEL MANAGEMENT SYSTEMS



DISPENSERS



KITS



PUMPS



METERS



NOZZLES

ACCESS 85

FEATURES

- ACCESS CONTROL
- SUITABLE FOR ANY PUMP AND SYSTEM
- READY TO USE
- MULTI USERS
- LEVEL CONTROL INPUT

The PIUSI ACCESS 85 is an electronic control unit that allows users to control the withdrawal of fuel from a tank by several users. It is able to control: pump start and stop, user access by means of electronic key, the position of the dispenser gun with relevant go ahead. It also features a built-in emergency button to stop all operations.

PERFORMANCE

UP TO

85

USERS

AC

CONTINUOUS DUTY

POWER



ACCESS 85



PACKAGING

CODE	WEIGHT		PACKAGING		
	KG	LBS	MM	INCH	PCS/BOX
FO0702000	0,7	1,5	120X140X200	4,7X5,5X7,9	1
FO0702010	0,7	1,5	120X140X200	4,7X5,5X7,9	1



FILTRATION



TANK MONITORING



HOSE REEL



ACCESSORIES



MERCHANDISE

INDEX



AIR



ANTIFREEZE



AdBlue®



BIODIESEL



DIESEL



FOOD



GASOLINE



GREASE



KEROSENE



OIL



WATER



WINDSCREEN

FUNCTIONING



PUMP CONTROL



NOZZLE SWITCH CONTROL



TANK ALARM CONTROL



IN THE BOX

- ACCESS 85 UNIT
- INSTRUCTION MANUAL

DETAILS

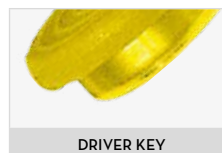

DRIVER KEY



EMERGENCY BUTTON

TECHNICAL DATA

CODE	DESCRIPTION	FLUIDS TYPE	USERS	USERS KEY	VOLTAGE		
					AC V./HZ	POWER WATT	AMP. MAX.
FO0702000	ACCESS 85	D G K O	85	NO	230	3,5	6
FO0702010	KIT ACCESS 85	D G K O	85	4	230	3,5	6

ACCESS 85



FUEL MANAGEMENT SYSTEMS



DISPENSERS



KITS



PUMPS



METERS



NOZZLES

CONNECTORS

FEATURES

- STURDY STRUCTURE
- READY TO USE
- SEVERAL SOLUTIONS AVAILABLE

The range of fuel products is completed with a wide array of accessories for connecting products to allow the best performance. Starting from the 2" connectors and quick coupling.

PERFORMANCE

2"

DRUM CONNECTOR

2"

QUICK COUPLING



2" DRUM CONNECTOR WITHOUT INTEGRATED VALVE



2" DRUM CONNECTOR WITH FLANGED AND INTEGRATED VALVE



2" DRUM CONNECTOR WITH INTEGRATED VALVE



2" QUICK COUPLING



PACKAGING

CODE	PACKAGING			
	KG	MM	INCH	PCS/BOX
2" CONNECTOR				
F17163000	0,6	133X98X85		1
F17190000	0,6	133X98X85		1
FO8934010	3,9	830X160X100		
F17163010	0,8	133X98X85		1
2" QUICK COUPLING				
RO9160000	0,9	133X98X85		1
FO893000A	0,9	133X98X85		1
EXTENSIBLE PIPE				
FO8934000	0,2	680X40X40		
FO8934020	1,9	680X40X40		1



FILTRATION



TANK MONITORING



HOSE REEL



ACCESSORIES



MERCHANDISE

INDEX



AIR



ANTIFREEZE



AdBlue®



BIODIESEL



DIESEL



FOOD



GASOLINE



GREASE



KEROSENE



OIL



WATER



WINDSCREEN

DIMENSIONS

COMPLETE KIT EXTENSIBLE SUCTION PIPE (1800MM)

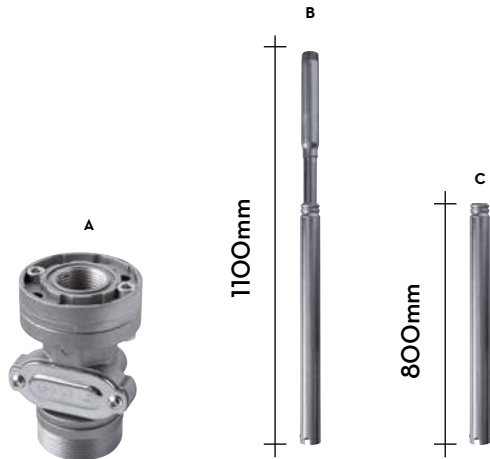

A:
DRUM CONNECTOR
FLANGED AND VALVE

B:
EXTENSIBLE STEEL
PIPE 1" BSP

C:
STEEL PIPE 1" BSP

CODE:
FO08934010

WEIGHT:
3,9 KG

PACKAGING:
820X150X100

IN THE BOX

- CONNECTOR
- INSTRUCTION MANUAL

DETAILS



DIMENSIONS

EXTENSIBLE PIPE PLASTIC MADE

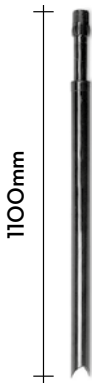

EXTENSIBLE STEEL PIPE 1" BSP



2" CONNECTOR



2" QUICK CONNECTOR

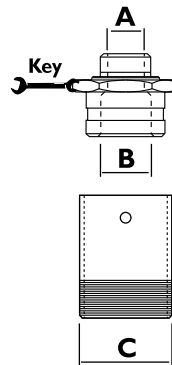

MATERIALS

- STEEL

Dimensions expressed in millimeters

TECHNICAL DATA

CODE	DESCRIPTION	FLUIDS TYPE	INTEGRATED VALVE	FILTER	INLET	OUTLET	THREADED FLANGE	A	B	C	KEY
					BSP	BSP	BSP	BSP	BSP	BSP	
2" CONNECTOR											
F17163000	DRUM CONNECTOR WITH INTEGRATED VALVE	D G K O	YES	YES	2"	-	NO	1"	1"	2"	-
F17190000	DRUM CONNECTOR WITHOUT INTEGRATED VALVE	D G K O	NO	YES	2"	-	NO	1"	1"	2"	-
F17163010	DRUM CONNECTOR WITH FLANGED AND INTEGRATED VALVE	D G K O	YES	YES	2"	1"	YES	1"	1"	2"	-
FO8934010	KIT EXTENSIBLE SUCTION PIPE 1" 1800MM	D G K O	YES	YES	2"	1"	YES	1"	1"	2"	-
2" QUICK COUPLING											
RO9160000	QUICK COUPLING 3/4"	D O	NO	NO	3/4"	1"	NO	M 3/4"	F 1"	M 2"	60
FO893000A	QUICK COUPLING 1"	D O	NO	NO	1"	1"	NO	M 1"	F 1"	M 2"	60
EXTENSIBLE PIPE											
FO8934000	EXTENSIBLE SUCTION PIPE 1" 1100MM PLAST.	D G K O	-	-	1"	1"	-	-	-	-	-
FO8934020	EXTENSIBLE SUCTION PIPE 1" 1100MM STEEL	D G K O	-	-	1"	1"	-	-	-	-	-

CONNECTORS



FUEL MANAGEMENT SYSTEMS



DISPENSERS



KITS



PUMPS



METERS



NOZZLES

COUPLING & FITTINGS

FEATURES

- EASY TO USE
- VERSATILITY AND SEVERAL SHAPES

PIUSI COUPLING & FITTINGS are engineered to fit every application context representing the perfect solution to connect the fuel equipment.

TECHNICAL DATA

CODE	DESCRIPTION	INLET / OUTLET			KEY		Q.TY
		A	B	C	1	2	

ELBOWS

FO7806000	ELBOW F 3/4" BSP / F 3/4" BSP	F 3/4" BSP	F 3/4" BSP	-	-	-	-
FO7805000	ELBOW M 3/4" BSP / F 3/4" BSP	M 3/4" BSP	F 3/4" BSP	-	-	-	-
FO8609000	ELBOW F 1" BSP / F 1" BSP - BRASS	F 1" BSP	F 1" BSP	-	-	-	-
FO7988000	ELBOW M 1" BSP / F 1" BSP - BRASS	M 1" BSP	F 1" BSP	-	-	-	-
FI4567000	ELBOW ROTATING CONNECTOR 90° 1" M/F	M 1" BSP	F 1" BSP	-	-	-	-



ROTATING ELBOWS



ELBOWS

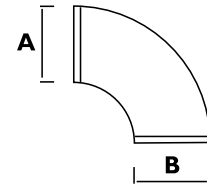

HOSE TAILS

FO826700A	HOSETAIL 1/2" X D.20 + OR	1/2" BSP	19 MM	-	24	-	1
FO643700A	HOSETAIL 3/4" X D.20 + OR (20 PCS)	3/4" BSP	19 MM	-	32	-	20
FO776800B	HOSETAIL 3/4" X D.25 + OR (20 PCS)	3/4" BSP	25 MM	-	32	-	20
FO775700A	HOSETAIL 1" X D.20 + OR (20 PCS)	1" BSP	19 MM	-	37	-	20
FO776400A	HOSETAIL 1" X D.25 + OR (20 PCS)	1" BSP	25 MM	-	37	-	20



HOSE TAILS

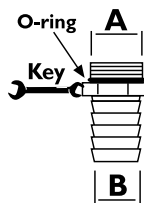

HQC

		KG.	MM.	PCS/BOX
FO0636000	HQC - HOSE QUICK COUPLING 1" BSP	0,46	80X80X75	1



HQC

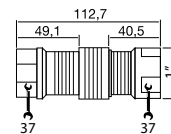

SEALANT PASTE

		GR.	ML.
FO8173000	ADEHESIVE PASTE LOXEAL 18-10	130	-
FI0767000	THREAD SEALANT BLUE LOXEAL 55.03		250
FI2278000	THREAD SEALANT GREEN LOXEAL 85.21		250



SEALANT PASTE



FILTRATION



TANK MONITORING



HOSE REEL



ACCESSORIES



MERCHANDISE

INDEX



AIR



ANTIFREEZE



AdBlue®



BIODIESEL



DIESEL



FOOD



GASOLINE



GREASE



KEROSENE



OIL



WATER



WINDSCREEN

TECHNICAL DATA

CODE	DESCRIPTION	INLET / OUTLET			KEY		Q.TY
		A	B	C	1	2	

SLEEVE

FO8137000	SLEEVE HOSE DIAM. 20	28 MM	20 MM	-	-	-	1
FO8138000	SLEEVE HOSE DIAM. 25	36 MM	28 MM	-	-	-	1
FI7126000	SLEEVE F 1" BSP / F 1" BSP (20 PCS)	F 1" BSP	F 1" BSP	-	-	-	20



SLEEVE

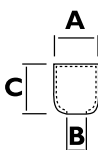

COUPLINGS

FO7762000	NIPPLE M 3/4" BSP / M 1" BSP	M 3/4" BSP	M 1" BSP	-	34	-	-
FO8913000	NIPPLE M 1" BSP - M 1/2" BSP	M 1" BSP	M 1" 1/2" BSP	-	30	-	-
FO7765000	NIPPLE M 1" BSP / M 1" BSP	M 1" BSP	M 1" BSP	-	34	-	-
FO7766000	NIPPLE M 3/4" BSP / M 3/4" BSP	M 3/4" BSP	M 3/4" BSP	-	34	-	-



NIPPLE

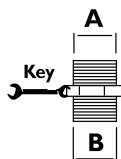

NIPPLE

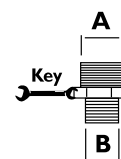

FITTINGS

FO7441000	FITTING M 3/4" BSP / F 1/2" BSP	F 1/2" BSP	M 3/4" BSP	-	27	-	-
FO7760000	FITTING M 1" BSP / F 3/4" BSP	F 3/4" BSP	M 1" BSP	-	34	-	-
FO7889000	FITTING F 1" BSP / M 3/4" BSP	F 1" BSP	M 3/4" BSP	-	-	-	-
FI425800A	ADAPTER FOR TANK 2" X D.36	F 2" BSP	D.36	-	-	-	-

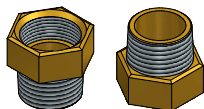

FITTINGS

SWIVEL UNION

000890000	SWIVEL UNION M 3/4" BSP X 27MM	3/4" BSP	19 MM	27 MM	38 MM	38 MM	-
000891000	SWIVEL UNION M 1" BSP X 27MM	1"	19 MM	27 MM	31 MM	31 MM	-
FO0892000	SWIVEL UNION M 1" BSP X 35MM	1"	25 MM	35 MM	38 MM	38 MM	-
000893000	SWIVEL UNION M 3/4" BSP X 32MM	3/4"	19 MM	32 MM	31 MM	31 MM	-
000894000	SWIVEL UNION M 1" BSP X 32MM	1"	19 MM	32 MM	38 MM	38 MM	-
000895000	SWIVEL UNION M 1" BSP X 38MM	1"	25 MM	38 MM	38 MM	38 MM	-



UNION



1



2



3



4

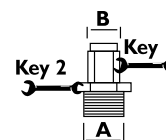
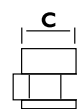



FUEL MANAGEMENT SYSTEMS



DISPENSERS



KITS



PUMPS



METERS



NOZZLES

FLANGED CONNECTIONS

FEATURES

- STURDY DESIGN
- EASY TO FIT
- SEVERAL SHAPES

Safe and guaranteed solutions to connect products: connections, elbows, full kits and flanges.

TECHNICAL DATA

CODE	DESCRIPTION	INLET / OUTLET				FLANGE	O-RING	OVAL RING	SCREW		GRUB SCREW	NUT
		A	B	C	H				M8X20 N°	M8X30 N°		

FLANGES

FO883200A	FLANGE D.80 1" E80/E120	-	1" BSP	80 MM	18 MM	-	-	-	-	-	-	-
F1290400A	KIT FLANGE 1" BSP	-	1" BSP	80 MM	18 MM	1	-	1	-	2	-	2
FO918000A	KIT FLANGE 1" BSP (2 PCS)	-	1" BSP	80 MM	18 MM	2	2	-	4	-	-	-
F1106200B	KIT FLANGE CUBE 70	-	1" BSP	80 MM	18 MM	1	1	-	2	-	-	-
RO841700O	KIT N°2 OR SEAL 3156	-	-	-	-	-	2	-	-	-	-	-
F1444500A	KIT FLANGE 3/4" BSP (2 PCS)	-	3/4" BSP	80 MM	18 MM	2	2	-	4	-	-	-
FO898500A	OR SEAL 3156 OVAL SECTION DIESEL ONLY	-	-	-	-	-	-	1	-	-	-	-
FO804300O	SCREW M8X30 N°10 PIECES	-	-	-	-	-	-	-	-	10	-	-



FLANGE

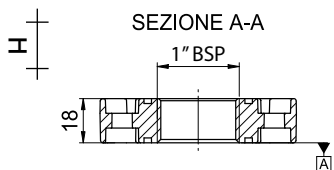
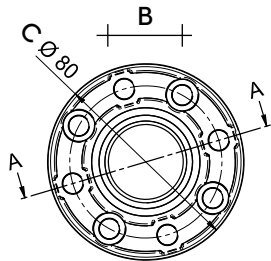

SCREW



NUT



FLANGE



O-RING



OVAL RING



GRUB SCREW

FLANGE KIT





FILTRATION



TANK MONITORING



HOSE REEL



ACCESSORIES



MERCHANDISE

INDEX



AIR



ANTIFREEZE



AdBlue®



BIODIESEL



DIESEL



FOOD



GASOLINE



GREASE



KEROSENE



OIL



WATER



WINDSCREEN

TECHNICAL DATA

CODE	DESCRIPTION	DIMENSIONS	FLANGE	O-RING	OVAL RING	SCREW		GRUB SCREW	NUT
		LENGTH	N°	N°	N°	M8X20 N°	M8X30 N°	M8X50 N°	M8 N°

FLANGED TUBE

F1217200A	FLANGED TUBE 341MM\$	341	-	-	-	-	-	-	-
F1222800B	FLANGED TUBE 300MM	300	-	-	-	-	-	-	-
F1082400A	KIT FLANGED + ELBOW + OR + SCREW	-	-	2	-	2	2	-	2

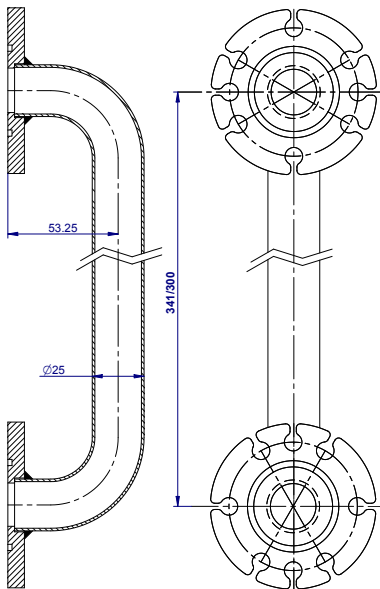

FLANGED TUBE 300/341

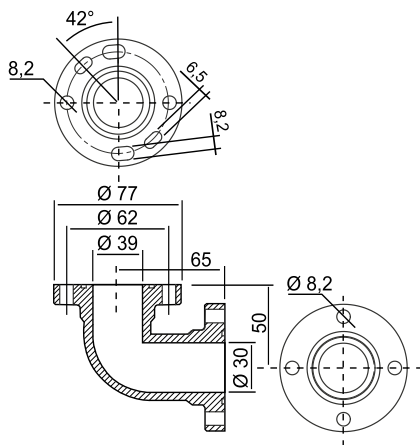

ELBOW



SCREW



NUT



FLANGE



O-RING

KIT FLANGED ELBOW

FLANGED CONNECTIONS



FUEL MANAGEMENT SYSTEMS



DISPENSERS



KITS



PUMPS



METERS



NOZZLES

HOSE & SWIVEL

Diesel fuel delivery hoses, suction hoses, crimped hoses, rotating hose connectors: a wide range to complete the accessories product range.

TECHNICAL DATA

CODE	DESCRIPTION	FLUIDS TYPE	PRESSURE		VACUUM	DIMENSIONS				KEY	CAMLOCK MALE/FEMALE BSP
			BAR	PSI		A MM	B MM	S MM	L M/FT.		

DELIVERY HOSES

FO060502A	DIESEL HOSE Ø20 PARKER 80 MT	D	10	-	-	20	27	-	80	-	-
FO060602A	DIESEL HOSE Ø25 PARKER 40MT	D	10	-	-	25	35	-	40	-	-

DELIVERY CRIMPED HOSES

F11885000	DIESEL HOSE Ø20 L=4M CRIMPED 3/4"X3/4"	D	10	-	-	3/4" BSP	3/4" BSP	20	4	-	-
FO8561000	DIESEL HOSE Ø20 L=4M CRIMPED 3/4"X1"	D	10	-	-	3/4" BSP	1" BSP	20	4	-	-
FO8976000	DIESEL HOSE Ø20 L=4M CRIMPED 1"X1"	D	10	-	-	1" BSP	1" BSP	20	4	-	-
F12876000	DIESEL HOSE Ø20 L=6M CRIMPED 3/4"X3/4"	D	10	-	-	3/4" BSP	3/4" BSP	20	6	-	-
F11063000	DIESEL HOSE Ø20 L=6M CRIMPED 3/4"X1"	D	10	-	-	3/4" BSP	1" BSP	20	6	-	-
FO8945000	DIESEL HOSE Ø20 L=6M CRIMPED 1"X1"	D	10	-	-	1" BSP	1" BSP	20	6	-	-
F11060000	DIESEL HOSE Ø20 L=7M CRIMPED 1"X1"	D	10	-	-	1" BSP	1" BSP	20	7	-	-
F12323000	DIESEL HOSE Ø20 L=8M CRIMPED 1"X1"	D	10	-	-	1" BSP	1" BSP	20	8	-	-
F11532000	DIESEL HOSE Ø20 L=10M CRIMPED 3/4"X1"	D	10	-	-	3/4" BSP	1" BSP	20	10	-	-
F12929000	DIESEL HOSE Ø20 L=10M CRIMPED 1"X1"PARKE	D	10	-	-	1" BSP	1" BSP	20	10	-	-
O11904000	CRIMPED HOSE Ø25 L=1.2M 1"X1"	D	10	-	-	1" BSP	1" BSP	25	1,2	-	-
F12794000	DIESEL HOSE Ø25 L=2M CRIMPED 1"X1"	D	10	-	-	1" BSP	1" BSP	25	2	-	-
FO8560000	DIESEL HOSE Ø25 L=3M 1"X1"	D	10	-	-	1" BSP	1" BSP	25	3	-	-
FO8977000	DIESEL HOSE Ø25 L=4M CRIMPED 1"X1"	D	10	-	-	1" BSP	1" BSP	25	4	-	-
F11264000	DIESEL HOSE Ø25 L=5M CRIMPED 1"X1"	D	10	-	-	1" BSP	1" BSP	25	5	-	-
FO8858000	DIESEL HOSE Ø25 L=6M CRIMPED 1"X1"	D	10	-	-	1" BSP	1" BSP	25	6	-	-
F12784000	DIESEL HOSE Ø25 L=7M CRIMPED 1"X1"	D	10	-	-	1" BSP	1" BSP	25	7	-	-
F11540000	DIESEL HOSE Ø25 L=8M CRIMPED 1"X1"	D	10	-	-	1" BSP	1" BSP	25	8	-	-
F12785000	DIESEL HOSE Ø25 L=10M CRIMPED 1"X1"	D	10	-	-	1" BSP	1" BSP	25	10	-	-
F14412000	DIESEL HOSE Ø25 L=12M CRIMPED 1"X1"	D	10	-	-	1" BSP	1" BSP	25	12	-	-



DISPENSING HOSES



RUBBER HOSE



RUBBER SUCTION HOSE



PVC HOSE

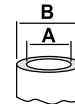

B

A



CRIMPED HOSE

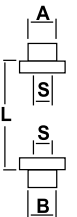

HOSE KIT 1" 1/2

F18798000	KIT HOSE 1 1/2" 10 MT+CAMLOCK+HOSETAIL	D	10	145	-	1" 1/2 BSP	-	-	-	-	1" 1/2 BSP
F18799000	KIT HOSE 1 1/2" 20 MT+CAMLOCK+HOSETAIL	D	20	65,6	-	1" 1/2 BSP	-	-	-	-	1" 1/2 BSP



HOSE KIT 1" 1/2



CAMLOCK



FILTRATION



TANK MONITORING



HOSE REEL



ACCESSORIES



MERCHANDISE

PIUSI

INDEX



AIR



ANTIFREEZE



AdBlue®



BIODIESEL



DIESEL



FOOD



GASOLINE



GREASE



KEROSENE



OIL



WATER



WINDSCREEN

TECHNICAL DATA

CODE	DESCRIPTION	FLUIDS TYPE	PRESSURE		VACUUM	DIMENSIONS				KEY	CAMLOCK
			BAR	PSI	BAR	A MM	B MM	S MM	L M/FT.		MALE/FEMALE BSP

SUCTION HOSES

F08870000	HOSE CARBUREX Ø25 50MT	D	10	-	-0,9	25	33	-	50	-	-
F12120010	SUCTION SPIRAL HOSE D.25 60MT	D B O	10	-	-0,9	25	35	-	60	-	-
F1113100B	SUCTION SPIRAL PVC HOSE D.25 60MT	D O	10	-	-0,9	25	33	-	60	-	-

SUCTION CRIMPED SPIRAL HOSES

F12117000	SUCTION SPIRAL HOSE D.25 CRIMP 1"/1" 1MT	D B O	10	-	-0,9	1" BSP	1" BSP	25	1	-	-
F12118000	SUCT SPIRAL HOSE D.25 CRIMP 1"/1" 1.5MT	D B O	10	-	-0,9	1" BSP	1" BSP	25	1,5	-	-
F12119000	SUCTION SPIRAL HOSE D.25 CRIMP 1"/1" 2MT	D B O	10	-	-0,9	1" BSP	1" BSP	25	2	-	-
F13768000	SUCT SPIRAL HOSE D.25 CRIMP 1"/1" 3.5MT	D B O	10	-	-0,9	1" BSP	1" BSP	25	3,5	-	-
F13695000	SUCTION SPIRAL HOSE D.25 CRIMP 1"/1" 5MT	D B O	10	-	-0,9	1" BSP	1" BSP	25	5	-	-
F1640400A	KIT SUCT SPIRAL HOSE D.25 W/VALVE 4MT	D B O	10	-	-0,9	1" BSP	1" BSP	25	4	-	-

SUCTION CRIMPED PVC SPIRAL HOSES

F1113200A	TRAS. PVC HOSE Ø25 L=1.6M CRIMPED 1"X1"	D O	10	-	-0,9	1" BSP	1" BSP	25	1,6	-	-
F11638010	TRAS. PVC HOSE Ø25 L=4M 1"X1" + FV	D O	10	-	-0,9	1" BSP	1" BSP	25	4	-	-



RUBBER HOSE



SPIRAL RUBBER HOSE



SPIRAL PVC HOSE

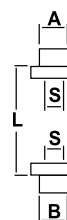

SWIVEL

000623000	SWIVEL M 3/4" BSP / M 1" BSP	-	-	-	-	M 3/4" BSP	M 1" BSP	-	-	94	-
00062400A	SWIVEL M 3/4" BSP / F 3/4" BSP	-	-	-	-	M 3/4" BSP	F 3/4" BSP	-	-	38	-
FO062000A	SWIVEL M 3/4" BSP / F 1" BSP	-	-	-	-	M 3/4" BSP	F 1" BSP	-	-	34	-
FO062200A	SWIVEL M 1" BSP / F 1" BSP	-	-	-	-	M 1" BSP	F 1" BSP	-	-	34	-
FO0623100	SWIVEL M 3/4" BSP / M 1" BSP W/FILTER	-	-	-	-	M 3/4" BSP	M 1" BSP	-	-	94	-
FO062500A	SWIVEL M 3/4" BSP X 20MM	-	-	-	-	M 3/4" BSP	20 MM	-	-	38	-



ROTATING SWIVEL



ROTATING HOSE CONNECTORS

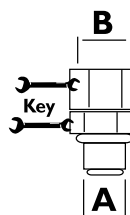

HOSE & SWIVEL



ACCESSORIES

ACCESS CONTROL

ACCESS 85	CODE	DESCRIPTION
	F1249600A	MANAGER KEY 2018
	F1590400A	KIT DRIVER KEY YELLOW (10PCS)
	F1623900B	NOZZLE HOLDER SS-CABLED SWITCH FM/MC
	F17121000	LEVEL PROBE FOR ACCESS 85



F1590400A



F1623900B



F1249600A



F17121000





MERCHANDISE





FUEL MANAGEMENT SYSTEMS



DISPENSERS



KITS



PUMPS



METERS



NOZZLES

MERCHANDISE



PACKAGING

CODE	DESCRIPTION	WEIGHT		PACKAGING			
		KG	LBS	MM	INCH	PCS/PALLET	PCS/BOX
T-SHIRT BLACK							
PBG000031	PIUSI T-SHIRT BLACK BOX 10 PCS - L	1	-	35X26X18	-	-	10
PBG000032	PIUSI T-SHIRT BLACK BOX 10 PCS - XL	1	-	35X26X18	-	-	10
T-SHIRT WHITE							
PBG000026	PIUSI T-SHIRT WHITE BOX 10 PCS - L	1	-	35X26X18	-	-	10
PBG000027	PIUSI T-SHIRT WHITE BOX 10 PCS - XL	1	-	35X26X18	-	-	10
PBG000029	PIUSI T-SHIRT WHITE BOX 10 PCS - M	1	-	35X26X18	-	-	10
WATER BOTTLE							
PBG000037	PIUSI WATER BOTTLE - BOX 20 PCS	-	-	-	-	-	20
CAP							
PBG000040	PIUSI CAP - BOX 10 PCS	-	-	-	-	-	10



FILTRATION



TANK MONITORING



HOSE REEL



ACCESSORIES



MERCHANDISE

PIUSI[®]

INDEX



PACKAGING

CODE	DESCRIPTION	WEIGHT		PACKAGING			
		KG	LBS	MM	INCH	PCS/PALLET	PCS/BOX
CROWNER							
PBA000013	PIUSI METALLIC FLOOR STAND	76	-	120X100 (PALLET)	-	1	-
POSTER							
PBPO00003	KIT POSTERS PIUSI - BOX 10 PCS	0,2	-	70X12	-	-	10
UMBRELLA							
PBG000030	PIUSI UMBRELLA - BOX 10 PCS	5,5	-	35X26X18	-	-	10
BAG							
PBG000035	PIUSI BAG 2018 - BOX 150 PCS	18,5	-	-	-	-	150
SPORTSPACK							
PBG000039	PIUSI SPORTSPACK - BOX 30 PCS	-	-	-	-	-	30
KEYRING							
PBG000041	PIUSI KEYRING - BOX 100 PCS	-	-	-	-	-	100

MERCHANDISE

PIUSI FLUIDS' INFORMATION

ATEX/IECEx

DIRECTIVE

SAFETY IN EXPLOSIVE ENVIRONMENTS

As of 1st July 2003, the ATEX directive came into force throughout the EEC. This directive became an obligatory requirement for all electrical and mechanical equipment intended for use in dangerous areas. Potentially explosive atmospheres exist where there is a risk of explosion due to mixtures of gas and air, steam and air, dust and air or other flammable combinations typical of petrol vapours.

If the electrical or mechanical material must be used in areas where there is an explosive atmosphere, it must be designed and built so as not to create/ to eliminate sources of ignition such as sparks, hot surfaces or static electricity and all sources of combustion able to ignite these mixtures. Risk areas for environments where gas and flammable vapours are present can range from AREA 0 (constant risk of explosion) to AREA 1 (risk of explosion probable) and AREA 2 (low risk and any risk of explosion persists for a short time only).

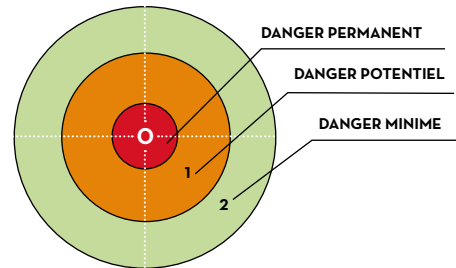
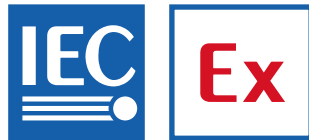

OUR PUMPS COMPLIES WITH THE FOLLOWING MARKING ATEX/IECEx

II	2	G	Ex	d	IIA	T4	Gb
GROUP	CATEGORY	TYPE OF EXPLOSIVE ATMOSPHERE	PERMANENT PREFIX	PROTECTION METHOD	GAS GLASS	TEMPERATURE CLASS	EQUIPMENT PROTECTION LEVEL

II = Group II comprises appliances intended for use in other environments (other than mining) in which explosive atmospheres are probable.

2 = High protection, Category 2 for AREA 1 GAS and AREA 2 GAS

G = Gas

Ex = Explosion-proof equipment certified according to the European ATEX directives

d = Explosion-proof cases (EN 60079-1)

IIA = Electrical appliances for potentially explosive environments other than mining. (Propane, Butane etc.)

T4 = The temperature of the pump will not exceed 135°C

PIUSI 's experience in the world of flammable liquids

PIUSI renews his natural propension to find solutions for the transfer of fluids, expanding its range with new products to dispensing flammable liquids.

Experience gained with pumps for transferring diesel fuel, combined with the growing demands of the market, have fostered the development of this new range of pumps for gasoline, kerosene and diesel, that satisfy the criteria of strict ATEX directives concerning the use of materials in potentially explosive atmospheres.

The PIUSI products have successfully obtained certification CESI and IECEx Certificate of Conformity.

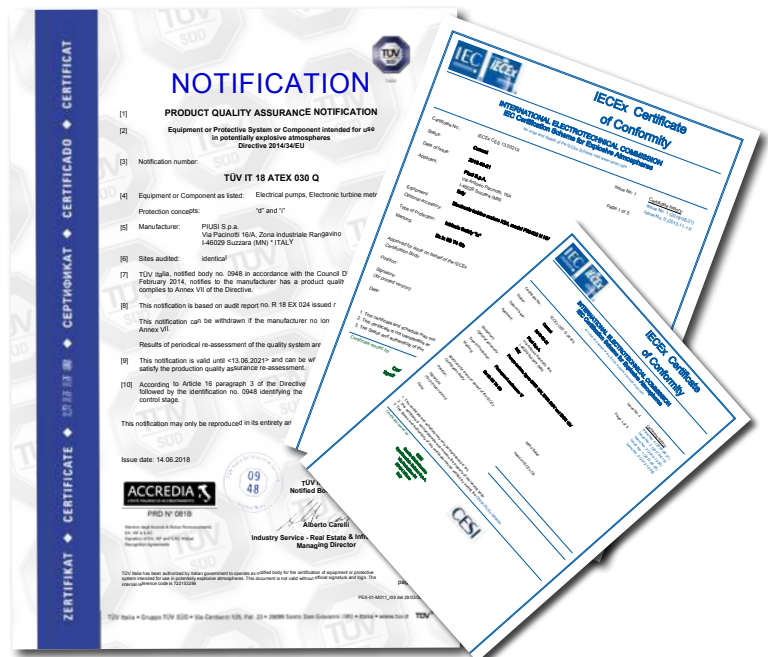

TYPE OF FLUIDS

AIR

A

ANTIFREEZE

A

AdBlue® (UREA)

Ad

BIODIESEL

B

DIESEL

D

FOOD

F

GASOLINE

G

GREASE

G^R

KEROSENE

K

OIL

O

WATER

W

WINDSCREEN

W_S

The intellectual property of this catalogue is assigned to all countries. Translation, reproduction, electronic storage and full or partial adaption by any means (including microfilms and photocopies) of its contents, without prior written authorisation from PIUSI S.p.a., entails a violation of PIUSI S.P.A's copyrights and constitutes an act of unfair competition. The products shown in the images of this catalogue are protected according to the regulation in force regarding industrial property. The information contained in this catalogue is as accurate as possible and complies, as far as possible, with existing regulations at the time of its publication. We therefore reserve the right to make subsequent modifications in line with modifications to regulations and/ or in relation to any production requirements that are deemed necessary for safety reasons. The technical specifications indicated in this catalogue cancel out and replace those already present in the previous general catalogue and in the product catalogues. The updates and product data sheets are available in PDF format on our website: www.piusi.com



PIUSI

CERTIFIED
ISO 9001 / ISO 14001

SINCE 1953, PIUSI HAS BEEN EMPLOYING ITALIAN ENGINEERING SKILLS AT THE SERVICE OF ITS CUSTOMERS, WITH PROFESSIONALISM AND INTEGRITY IN ORDER TO BUILD STABLE AND LASTING RELATIONSHIPS.

OUR MISSION IS TO PROVIDE SIMPLE, INTELLIGENT AND PROFESSIONAL SOLUTIONS FOR THE TRANSFER, DISPENSE AND MEASUREMENT OF LUBRICANTS, FUELS AND LIQUIDS, WITH THE HIGHEST CONSIDERATION FOR HUMAN AND ENVIRONMENTAL HEALTH.



*PIUSI S.p.A.
Headquarters
46029 Suzzara (Mantova) Italy
tel.+39 0376 534561
fax.+39 0376 536393
e-mail: piusi@piusi.com
www.piusi.com*



*PIUSI USA, Inc.
3901 Anglers Avenue
Fort Lauderdale, FL 33312
tel.: 954 584 1552
fax.: 954 584 1554
Email: piusiusa@piusiusa.com
www.piusiusa.com*